



THE SCHOOL BOARD OF BROWARD COUNTY, FLORIDA

7720 WEST OAKLAND PARK BOULEVARD, SUITE 323, SUNRISE, FLORIDA 33351 · TEL 754-321-0505 · FAX 754-321-0936

PROCUREMENT & WAREHOUSING SERVICES

MARY CATHERINE COKER, DIRECTOR

www.BrowardSchools.com

**The School Board of
Broward County, Florida**

Abby M. Freedman, Chair
Nora Rupert, Vice Chair

Robin Bartleman
Heather P. Brinkworth
Donna P. Korn
Patricia Good
Laurie Rich Levinson
Ann Murray
Dr. Rosalind Osgood

Robert W. Runcie
Superintendent of Schools

July 31, 2017

ADDENDUM 5 BID No. 18-027B CAFETERIA EQUIPMENT

TO: ALL BIDDERS

This Addendum amends the above-referenced Bid in the following particulars only:

1. Please see responses to latest questions.
2. Please substitute the following bid page (attached):

DELETE: Page 58 of 173 Pages-REVISED **INSERT:** Page 58 of 173 Pages –REVISED

This Addendum is for informational purposes only and need not be returned with your bid. By virtue of signing the "Invitation to Bid", Page 1 of Bid No. 18-027B, Bidder certifies acceptance of this Addendum.

Sincerely,

Larissa Seda

Larissa M. Seda
Purchasing Agent



THE SCHOOL BOARD OF BROWARD COUNTY, FLORIDA

PROCUREMENT & WAREHOUSING SERVICES

- **QUESTION #1:**
"Ice-O-Matic has an ICE0520A that is Energy Star rated. Can it be approved as an Item 41A approved brand?"

- **ANSWER TO QUESTION #1:**
No, it cannot be approved for item 41. Item 41 is intended for smaller programs (i.e. elementary schools), due to its smaller capacity bin, smaller machine size, and lower amp draw. The machine proposed (ICE520A) has more capacity, size and energy properties than what's required for smaller programs.

- **QUESTION #2:**
"The Accutemp model specified for 27E will not hold 6- 4" 12x20 pans, it will hold: 6 – 2.5" deep 12"x20" pans or 4- 4" deep 12" x 20" pans"

- **ANSWER TO QUESTION #2:**
Please see revised bid pages attached.

SECTION 6 - BID SPECIFICATIONS (CONTINUED)

In order to be considered for award, Bidders must fill these Bid Specifications Forms and the Electronic Bid Summary Sheet and submit them with their bid, in time for bid opening.

ITEM 27 – TO BE AWARDED AS A GROUP - CONTINUED

Item #

27D SAP Number: 6001223
Item Name: OVEN, CONVECTION DOUBLE STACK - ELECTRIC
Description: Same as Item 27C, except 480Volt, three phase.

 Approved Brand: Blodgett Model Mark V-100 ONLY

Brand Offered: _____

Model Offered: _____

Warranty Period: _____
Delivery
(days ARO): _____

Item #

27E SAP Number: 6000131
Item Name: BOILERLESS ONE-COMPARTMENT STEAMER
Description: Steamer cavity to be constructed of reinforced 14 gauge 304 stainless steel. Stainless steel support stand. Steamer with flanged feet. No moving parts inside cooking chamber. Steam to be produced inside. Cooking cavity with no heating element exposed to water. Easily connects to water and drain Line. Unit to include low water, high water, overtemp warning lights and auto shut off feature. No water filtration or treatment required. No scheduled delimiting or maintenance. Holds 4 each full size 12 x 20 x 4" steamtable pans. Standard digital or manual controls with independent timer. 3/4" water connection in back of unit for automatic water fill. Water drain in front. U.L. and NSF approved. Energy Star qualified. AMP draw not to exceed 42.0 at 208v, 3 phase. Left hand hinge doors.

Bid price to include stainless steel stand with pan slides and installation of steamer on stand, leveling of unit.

Warranty: Two year warranty, all parts and labor must be included in the unit price.

Approved Brand: Accutemp E62083E150SGL ONLY

Brand Offered: _____

Model Offered: _____

Warranty Period: _____
Delivery
(days ARO): _____



THE SCHOOL BOARD OF BROWARD COUNTY, FLORIDA

7720 WEST OAKLAND PARK BOULEVARD, SUITE 323, SUNRISE, FLORIDA 33351 · TEL 754-321-0505 · FAX 754-321-0936

PROCUREMENT & WAREHOUSING SERVICES

MARY CATHERINE COKER, DIRECTOR

www.BrowardSchools.com

The School Board of
Broward County, Florida

Abby M. Freedman, Chair
Nora Rupert, Vice Chair

Robin Bartleman
Heather P. Brinkworth
Donna P. Korn
Patricia Good
Laurie Rich Levinson
Ann Murray
Dr. Rosalind Osgood

Robert W. Runcie
Superintendent of Schools

July 20, 2017

ADDENDUM 4 BID No. 18-027B CAFETERIA EQUIPMENT

TO: ALL BIDDERS

This Addendum amends the above-referenced Bid in the following particulars only:

1. Please see responses to latest question.
2. Please substitute the following bid pages (attached):

DELETE: Page 133 of 173 Pages-REVISED	INSERT: Page 133 of 173 Pages – SECOND REVISION
DELETE: Page 134 of 173 Pages-REVISED	INSERT: Page 134 of 173 Pages – SECOND REVISION
3. During the week of July 24, 2017 through July 28, 2017, if bidders encounter issues with any aspect of this bid, inquiries shall be sent to jodihart@browardschools.com. Provide as much detail as possible and enter *****URGENT- ISSUE WITH BID 18-027B***** in the subject line.

This Addendum is for informational purposes only and need not be returned with your bid. By virtue of signing the "Invitation to Bid", Page 1 of Bid No. 18-027B, Bidder certifies acceptance of this Addendum.

Sincerely,

Larissa Seda

Larissa M. Seda
Purchasing Agent



➤ **QUESTION #1:**

"Item 41A the correct Scotsman model # is C0322SA-1 not C0332SA-1. Item 42A the description calls for a medium cube (7/8 x 7/8 x 7/8) but the model number is for a small cube (7/8 x 7/8 x 3/8). Please clarify"

➤ **ANSWER TO QUESTION #1:**

Please see revised bid pages attached.

SECTION 6 - BID SPECIFICATIONS – (CONTINUED)

In order to be considered for award, Bidders must fill these Bid Specifications Forms and the Electronic Bid Summary Sheet and submit them with their bid, in time for bid opening.

ITEM 41 – TO BE AWARDED AS A GROUP

Item #

41A SAP Number: 6000808

Item Name: **AUTOMATIC ICE MAKING MACHINE, 249 LBS. MINIMUM**

Description: Modular air cooled ice maker, ARI standard minimum of 249 lbs. at 90° air and 70° water. **Medium** ice cube size – 7/8" x 7/8" x 7/8". Corrosion-resistant stainless steel exterior. **Front located air filter**. 115/60/1 electric requirements only. Max. fuse size 15 amps. Unit to be 22" wide. Air cooled. Complete with factory approved water filter.
 WARRANTY: 3 year parts and labor on all components; 5-7 year parts & labor on evaporator; 5 year parts on compressor, condenser.
Note: Unit price shall include installation, set up, placement, shipping, free warranty service calls while machine under warranty, start-up, parts manual. SBBC shall supply existing water line, electric outlets, and drainage.
MUST BE ENERGY STAR RATED
 Approved Brands:
Scotsman C0322MA-1A, Hoshizaki KM-340 MAH ONLY.

Brand Offered: _____

Model Offered: _____

Warranty Period: _____
Delivery (days ARO): _____

Item #

41B SAP Number: 6000805

Item Name: **BIN – 360 LBS. MINIMUM**

Description: Holds minimum 360 lbs. To be compatible with Item A. To have minimum storage capacity of 360 lbs. Front door and sides of bin to be stainless steel or polyethylene exterior. 6" adjustable legs. Foamed-in-place polyurethane insulation. Non-corrosive polyliner. NSF and UL listed.
WARRANTY: 3 year parts and labor.

Approved Brands:
Scotsman B322S, Hoshizaki B-300SF ONLY

Brand Offered: _____

Model Offered: _____

Warranty Period: _____
Delivery (days ARO): _____

SECTION 6 - BID SPECIFICATIONS – (CONTINUED)

In order to be considered for award, Bidders must fill these Bid Specifications Forms and the Electronic Bid Summary Sheet and submit them with their bid, in time for bid opening.

ITEM 42 – TO BE AWARDED AS A GROUP

Item #

42A SAP Number: 6000803

Item Name: AUTOMATIC ICE MAKING MACHINE, 368 LBS. MINIMUM

Description: (330 lbs.) Modular air cooled ice maker, ARI standard minimum of 368 lbs. at 90° air and 70° water. Medium ice cube size – 7/8" x 7/8" x 7/8". Corrosion-resistant stainless steel exterior. Side or front located air filter. 115/60/1 electric requirements only. 30" wide. Air cooled. Complete with factory approved water filter. WARRANTY: 3 year parts and labor on all components; 5-7 year parts & labor on evaporator; 5 year parts on compressor, condenser.

Note: Unit price shall include installation, set up, placement, shipping, free warranty service calls while machine under warranty, start-up, parts manual. SBBC shall supply existing water line, electric outlets, and drainage.

MUST BE ENERGY STAR RATED

Approved Brands:

Scotsman C0530MA-1A, Manitowac ID0502-A, Ice-O-Matic ICE0400FA, Hoshizaki KM-515MAH ONLY.

Brand Offered: _____

Model Offered: _____

Warranty Period:
Delivery
(days ARO): _____

Item #

42B SAP Number: 6000804

Item Name: BIN, 500 LBS. MINIMUM

Description: To be compatible with Item A. Holds minimum 500 lbs. Front door and sides of bin to be stainless steel or polyethylene exterior. 6" adjustable legs. Foamed-in-place polyurethane insulation. Non-corrosive polyliner. NSF and UL listed. WARRANTY: 3 year parts and labor.

Approved Brands:

Scotsman B530P, Ice-O-Matic B55, Hoshizaki B-500 SF, Manitowac B-570 ONLY

Brand Offered: _____

Model Offered: _____

Warranty Period:
Delivery
(days ARO): _____



THE SCHOOL BOARD OF BROWARD COUNTY, FLORIDA

7720 WEST OAKLAND PARK BOULEVARD, SUITE 323, SUNRISE, FLORIDA 33351 · TEL 754-321-0505 · FAX 754-321-0936

PROCUREMENT & WAREHOUSING SERVICES

MARY CATHERINE COKER, DIRECTOR

www.BrowardSchools.com

**The School Board of
Broward County, Florida**

Abby M. Freedman, Chair
Nora Rupert, Vice Chair

Robin Bartleman
Heather P. Brinkworth
Donna P. Korn
Patricia Good
Laurie Rich Levinson
Ann Murray
Dr. Rosalind Osgood

Robert W. Runcie
Superintendent of Schools

July 20, 2017

ADDENDUM 3 BID No. 18-027B CAFETERIA EQUIPMENT

TO: ALL BIDDERS

This Addendum amends the above-referenced Bid in the following particulars only:

1. Please substitute the following bid pages (attached):

DELETE: Page 46 of 173 Pages-REVISED **INSERT:** Page 46 of 173 Pages – **SECOND REVISION**

DELETE: Page 47 of 173 Pages-REVISED **INSERT:** Page 47 of 173 Pages – **SECOND REVISION**

DELETE: Page 48 of 173 Pages-REVISED **INSERT:** Page 48 of 173 Pages – **SECOND REVISION**
(Page 48 of the Bid now returns to its original form as initially posted on Demandstar.)

This Addendum is for informational purposes only and need not be returned with your bid. By virtue of signing the "Invitation to Bid", Page 1 of Bid No. 18-027B, Bidder certifies acceptance of this Addendum.

Sincerely,

Larissa Seda

Larissa M. Seda
Purchasing Agent



THE SCHOOL BOARD OF BROWARD COUNTY, FLORIDA

PROCUREMENT & WAREHOUSING SERVICES

- **QUESTION #1:**
"Per Addendum 1 item #19 (revised) now has the same SAP number as item #18."

- **ANSWER TO QUESTION #1:**
Please see revised bid pages attached.

- **QUESTION #2:**
"Will they be sending a revised electronic Data Submittal worksheet as the items per the addendums will be different."

- **ANSWER TO QUESTION #2:**
With this correction, the items in the electronic Data Submittal worksheet will match the items in the Bid Specifications. There won't be a need to release another version.

SECTION 6 - BID SPECIFICATIONS (CONTINUED)

In order to be considered for award, Bidders must fill these Bid Specifications Forms and the Electronic Bid Summary Sheet and submit them with their bid, in time for bid opening.

Item #

18 SAP Number: 6000810

Item Name: FREEZER, REACH-IN, SELF-CONTAINED, THREE DOOR

Description: Freezer construction to be heavy gauge polished stainless steel exterior door, front, sides, & interior floor. Aluminum interior side walls and back. 20 gauge stainless steel door. Unit must have reinforced 20-gauge bottom to withstand heavy loads. Foamed-in-Place Polyurethane Insulation throughout. Front shroud to lift up for easy access to clean condenser coil. Maintains temperatures of 0 to -5 degrees in ambient temperatures of up to 100 degrees. Refrigeration to be R-404a or R290 where available. Top mount refrigeration system with expansion valve. Capacity: minimum 70 cu. ft. of usable space. Heavy duty 5" polyurethane plate casters, 2 with brakes. Each compartment shall have a stainless steel floor rack. Self-closing door with stay open feature. Cam-lift hinges with safety stop at 120 degrees. Heavy duty cylinder or bolt locks. Electronic controller with exterior digital temperature display; automatic LED lighting with door switch. Durable removable magnetic snap-in gasket. Anti-condensate door perimeter heaters concealed with high impact non-conductive thermal breaker.

Non-electric condensate evaporator top mounted that disposes of water automatically with pan of sufficient size to accommodate condensation. No plumbing required. Power supply at top. Provide evaporator coil out of food zone.

Furnished with nine heavy-duty epoxy coated shelves, three per door to accommodate 18" x 26" sheet pans in each full door. Size: Maximum height 84-1/4" high, max. depth 35", length 76 - 78". Electrical: 208/-230/60/1, not to exceed 13.0 AMPS. Condensing unit 3/4 HP. Unit to be NSF and UL listed.

Warranty: Three year manufacturer's warranty on all parts and labor plus warranty against condensation build up, five year warranty parts and labor on compressor must be included in the unit price. Warranty on compressor to include shipping and pick up of old compressor upon phone call to factory.

Set-up will include installation of shelves and clips and installation of wheels. Uncrated and remove crate. Unit must be shipped with parts manual and schematics to each location.

Approved Brand: Victory Model FSA-3D-S1 or other brands meeting bid specifications

Brand Offered: _____

Model Offered: _____

Warranty Period: _____

Delivery (days ARO): _____

SECTION 6 - BID SPECIFICATIONS (CONTINUED)

In order to be considered for award, Bidders must fill these Bid Specifications Forms and the Electronic Bid Summary Sheet and submit them with their bid, in time for bid opening.

Item #

19 SAP Number: 6000811

Item Name: FREEZER, REACH-IN, SELF-CONTAINED – TWO DOOR

Description: Freezer construction to be heavy gauge polished stainless steel exterior door, front, sides, & interior floor. 20 gauge stainless steel door. Unit must have reinforced 20 gauge bottom to withstand heavy loads. Aluminum interior side walls and back. Foamed-in-Place Polyurethane Insulation throughout. Front shroud to lift up for easy access to clean condenser coil. Maintains temperatures of 0 to -5 degrees in ambient temperatures of up to 100 degrees. Refrigeration to be R-404a or R290 where available. Top mount refrigeration system with expansion valve. Capacity: minimum 46.5 cu. ft. of usable space. Heavy duty 5" polyurethane plate casters, 2 with brakes. Each compartment shall have a stainless steel floor rack.

Self-closing door with stay open feature. Cam-lift hinges with safety stop at 120 degrees. Heavy duty cylinder or bolt locks. All doors keyed alike. Electronic controller with exterior digital temperature display; automatic LED lighting with door switch. Durable removable magnetic snap-in gasket. Breaker strips shall leave no exposed electrical heating elements and securely installed around entire perimeter of front frame and mullions of all door openings. Anti condensate door perimeter heaters.

Non-electric condensate evaporator top mounted that disposes of water automatically with pan of sufficient size to accommodate condensation. No plumbing required. Power supply at top. Provide evaporator coil out of food zone.

Furnish with six heavy-duty epoxy coated shelves, to-accommodate 18" x 26" pans, three per door. Size: Maximum height 84-1/4" high on wheels, max. depth 35", length 52 – 53". Electrical: 115/60/1, not to exceed 12 AMPS. 1/2 or 3/4 HP condensing unit. Unit to be NSF and UL listed.

Warranty: Three year manufacturer's warranty on all parts and labor plus warranty against condensation build up, five year warranty on compressor must be included in the unit price. Set-up will include installation of shelves and clips and installation of wheels. Uncrate, set-in place, remove all cartons. Unit must be shipped with parts manual and schematics to each location.

Approved Brands: Victory Model FSA-2D-S1 or other brands meeting bid specifications

Brand Offered: _____

Model Offered: _____

Warranty Period: _____

Delivery (days ARO): _____



THE SCHOOL BOARD OF BROWARD COUNTY, FLORIDA

7720 WEST OAKLAND PARK BOULEVARD, SUITE 323, SUNRISE, FLORIDA 33351 · TEL 754-321-0505 · FAX 754-321-0936

PROCUREMENT & WAREHOUSING SERVICES

MARY CATHERINE COKER, DIRECTOR

www.BrowardSchools.com

The School Board of
Broward County, Florida

Abby M. Freedman, Chair
Nora Rupert, Vice Chair

Robin Bartleman
Heather P. Brinkworth
Donna P. Korn
Patricia Good
Laurie Rich Levinson
Ann Murray
Dr. Rosalind Osgood

Robert W. Runcie
Superintendent of Schools

July 18, 2017

ADDENDUM 2 BID No. 18-027B CAFETERIA EQUIPMENT

TO: ALL BIDDERS

This Addendum amends the above-referenced Bid in the following particulars only:

1. Attached are the responses to the questions received.
2. Please substitute the following bid pages (attached):

DELETE: Page 133 of 173 Pages	INSERT: Page 133 of 173 Pages – REVISED –
DELETE: Page 134 of 173 Pages	INSERT: Page 134 of 173 Pages – REVISED –
3. **IMPORTANT REMINDERS** about the EXCEL file attachment for price information submittal:
 - a) After downloading the file from Demandstar, click "Enable Editing", if prompted; this will allow access to use the sheet.
 - b) The file is a password-protected document that allows entering data ONLY in cell C2 ("Type Bidder's Name Here") and in Column G ("Price per Unit of Measure").
 - c) During the week of July 24, 2017 through July 28, 2017, if bidders encounter issues with any aspect of this bid, inquiries shall be sent to jodihart@browardschools.com. Provide as much detail as possible and enter "***URGENT- ISSUE WITH BID 18-027B**" in the subject line.
 - d) In the event that the Bidder is unable to use the Excel file, information can be entered in ink. The calculations will be done during bid evaluation.

This Addendum is for informational purposes only and need not be returned with your bid. By virtue of signing the "Invitation to Bid", Page 1 of Bid No. 18-027B, Bidder certifies acceptance of this Addendum.

Sincerely,

Larissa Seda

Larissa M. Seda
Purchasing Agent



➤ **QUESTION #1:**

"Looking at Manitowoc 's web site, price list, and spec sheets, there is nothing in their literature to indicate that the ID0502-A is Energy Star qualified. Based on the Energy Star criteria, they should not be able to win the Ice Machine Group unless they have a machine for this item that is Energy Star.

It appears we will also not be able to bid the Ice Group due to a similar situation for Item 42A with our Ice-O-Matic line.

I looked up all the ice machine models such as Scotsman and Hoshizki, and Scotsman and Hoshizaki do qualify with the models listed for 41A and 41B.

Manitowoc and Ice-O-Matic do not qualify with the models listed in 41A, although Manitowoc has a non-Energy Star machine listed as an approved brand."

➤ **ANSWER TO QUESTION #1:**

Manitowoc ID502A is an Energy Star Qualified model. However, Manitowoc ID322A is not an Energy Star rated model. Please see the revised bid specifications sheets attached.

SECTION 6 - BID SPECIFICATIONS – (CONTINUED)

In order to be considered for award, Bidders must fill these Bid Specifications Forms and the Electronic Bid Summary Sheet and submit them with their bid, in time for bid opening.

ITEM 41 – TO BE AWARDED AS A GROUP

Item #

41A SAP Number: 6000808

Item Name: **AUTOMATIC ICE MAKING MACHINE, 249 LBS. MINIMUM**

Description: Modular air cooled ice maker, ARI standard minimum of 249 lbs. at 90° air and 70° water. Medium ice cube size – 7/8" x 7/8" x 7/8". Corrosion-resistant stainless steel exterior. No air filter or front located air filter. 115/60/1 electric requirements only. Max. fuse size 15 amps. Unit to be 22" wide. Air cooled. Complete with factory approved water filter.
WARRANTY: 3 year parts and labor on all components; 5-7 year parts & labor on evaporator; 5 year parts on compressor, condenser.
Note: Unit price shall include installation, set up, placement, shipping, free warranty service calls while machine under warranty, start-up, parts manual. SBBC shall supply existing water line, electric outlets, and drainage.
MUST BE ENERGY STAR RATED
Approved Brands:
Scotsman C0332SA-1A, Hoshizaki KM-340 MAH ONLY.

Brand Offered: _____

Model Offered: _____

Warranty Period: _____
Delivery (days ARO): _____

Item #

41B SAP Number: 6000805

Item Name: **BIN – 360 LBS. MINIMUM**

Description: Holds minimum 360 lbs. To be compatible with Item A. To have minimum storage capacity of 360 lbs. Front door and sides of bin to be stainless steel or polyethylene exterior. 6" adjustable legs. Foamed-in-place polyurethane insulation. Non-corosive polyliner. NSF and UL listed.
WARRANTY: 3 year parts and labor.

Approved Brands:
Scotsman B322S, Hoshizaki B-300SF ONLY

Brand Offered: _____

Model Offered: _____

Warranty Period: _____
Delivery (days ARO): _____

SECTION 6 - BID SPECIFICATIONS (CONTINUED)

In order to be considered for award, Bidders must fill these Bid Specifications Forms and the Electronic Bid Summary Sheet and submit them with their bid, in time for bid opening..

ITEM 42 – TO BE AWARDED AS A GROUP

Item #

42A SAP Number: 6000803

Item Name: AUTOMATIC ICE MAKING MACHINE, 368 LBS. MINIMUM

Description: (330 lbs.) Modular air cooled ice maker, ARI standard minimum of 368 lbs. at 90° air and 70° water. Medium ice cube size – 7/8" x 7/8" x 7/8". Corrosion-resistant stainless steel exterior. No air filter or front located air filter. 115/60/1 electric requirements only. 30" wide. Air cooled. Complete with factory approved water filter. WARRANTY: 3 year parts and labor on all components; 5-7 year parts & labor on evaporator; 5 year parts on compressor, condenser.

Note: Unit price shall include installation, set up, placement, shipping, free warranty service calls while machine under warranty, start-up, parts manual. SBBC shall supply existing water line, electric outlets, and drainage.

MUST BE ENERGY STAR RATED

Approved Brands:
Scotsman C0530SA-1A, Manitowac ID0502-A, Ice-O-Matic ICE0400A, Hoshizaki KM-515MAH ONLY.

Brand Offered: _____

Model Offered: _____

Warranty Period: _____
Delivery (days ARO): _____

Item #

42B SAP Number: 6000804

Item Name: BIN, 500 LBS. MINIMUM

Description: To be compatible with Item A. Holds minimum 500 lbs. Front door and sides of bin to be stainless steel or polyethylene exterior. 6" adjustable legs. Foamed-in-place polyurethane insulation. Non-corrosive polyliner. NSF and UL listed. WARRANTY: 3 year parts and labor.

Approved Brands:
Scotsman B530P, Ice-O-Matic B55, Hoshizaki B-500 SF, Manitowac B-570 ONLY

Brand Offered: _____

Model Offered: _____

Warranty Period: _____
Delivery (days ARO): _____



THE SCHOOL BOARD OF BROWARD COUNTY, FLORIDA

7720 WEST OAKLAND PARK BOULEVARD, SUITE 323, SUNRISE, FLORIDA 33351 · TEL 754-321-0505 · FAX 754-321-0936

PROCUREMENT & WAREHOUSING SERVICES

MARY CATHERINE COKER, DIRECTOR

www.BrowardSchools.com

The School Board of
Broward County, Florida

Abby M. Freedman, Chair
Nora Rupert, Vice Chair

Robin Bartleman
Heather P. Brinkworth
Donna P. Korn
Patricia Good
Laurie Rich Levinson
Ann Murray
Dr. Rosalind Osgood

Robert W. Runcie
Superintendent of Schools

July 13, 2017

ADDENDUM 1 BID No. 18-027B CAFETERIA EQUIPMENT

TO: ALL BIDDERS

This Addendum amends the above-referenced Bid in the following particulars only:

1. As a reminder, the due date for this ITB is August 2, 2017 at 2:00 p.m. ET.
2. Attached are the responses to the questions received.
3. Please substitute the following bid pages (attached):

DELETE: Page 11 of 173 Pages	INSERT: Page 11 of 173 Pages – REVISED –
DELETE: Page 41 of 173 Pages	INSERT: Page 41 of 173 Pages – REVISED –
DELETE: Page 42 of 173 Pages	INSERT: Page 42 of 173 Pages – REVISED –
DELETE: Page 47 of 173 Pages	INSERT: Page 47 of 173 Pages – REVISED –
DELETE: Page 48 of 173 Pages	INSERT: Page 48 of 173 Pages – REVISED –
4. On Item 30 – “GROUP ITEM 30 NOTES”, line 1 should read:
“1. SERVING LINES MAY BE ORDERED IN ANY CONFIGURATION OF ITEMS INCLUDED IN GROUP 30.”
5. On Item 30 - “GROUP ITEM 30 NOTES”, line 4 should read:
“4. SEE SPECIAL CONDITION 16 – PLACEMENT, SET-UP AND INSTALLATION (FOR BID ITEM 30)”
6. Before submitting your bid response, please ensure that:
 - a. Section 1, **Bidder Acknowledgement** is fully completed and signed as per General Condition 1.
 - b. Section 7, Attachment 4 (**Legal Opinion of Bidder’s Preference**) is accurately completed, signed, and submitted with your bid as indicated in Special Condition 6.
 - c. Exhibit B – **Certification of Debarment, Suspension, Ineligibility and Voluntary Exclusion** is completed, executed and submitted with your bid as indicated in Special Condition 7.
 - d. Bid Specifications Sheets and electronic (Excel [.xls]) Bid Summary Sheets are completed and submitted as indicated in Special Condition 2-**BID SUBMITTAL** and Special Condition 3 – **AWARD**.



- e. Entries are checked for accuracy. If bidding on an item or group of items, it is necessary to provide information **both** on the electronic (Excel [.xls]) Bid Summary Sheet and in the corresponding Bid Specifications pages. For items in GROUPS, it is necessary to bid on every item in the group and all items in the group must meet specifications to be considered for award.

This Addendum is for informational purposes only and need not be returned with your bid. By virtue of signing the "Invitation to Bid", Page 1 of Bid No. 18-027B, Bidder certifies acceptance of this Addendum.

Sincerely,

Larissa Seda

Larissa M. Seda
Purchasing Agent



➤ **QUESTION #1:**

"On items 41A and 41B, can Ice-O-Matic be an approved brand like it is on items 42A and 42B?"

ANSWER TO QUESTION #1:

Please refer to item specifications which state "MUST BE ENERGY STAR RATED".

➤ **QUESTION #2:**

"I would like to know will the district require equipment to be delivered to one central location such as the central warehouse or will the vendor be required to deliver to individual schools?"

ANSWER TO QUESTION #2:

Items will be delivered to individual schools.

➤ **QUESTION #3:**

"Will the vendor be responsible for setting the equipment in place."

ANSWER TO QUESTION #3:

Yes. Please refer to Special Condition16 – PLACEMENT, SET-UP AND INSTALLATION.

➤ **QUESTION #4:**

Will the vendor be responsible for removing the old equipment?

ANSWER TO QUESTION #4:

No. Please refer to Special Condition16 – PLACEMENT, SET-UP AND INSTALLATION.

➤ **QUESTION #5:**

"The Rfp does not have drawings for items 43 A thru K. Should there be drawings for these items?"

ANSWER TO QUESTION #5:

There are no drawings for this item. Units are customized for the individual school, and the manufacturer will provide bidder and SBBC with a drawing after bidder's receipt of P.O.

15. INSTALLATION (Continued):

- A. Awardee/Installer shall furnish, at their own expense, all supervision, equipment, machines, tools, materials, labor, transportation and all necessary items needed to perform site preparation and installation of equipment.
- B. Awardee shall protect all personnel (school staff and installer's employees), and students or others on school campuses against hazards and/or injuries that might result installer's work since generally the site preparation and installation of equipment will occur while school is in session. This shall include, but not be limited to the erection of barricades and signs to isolate the worksite and minimize the risk of injury to anyone on the school campus or site location.
- C. Unpack, uncrate and install equipment at the site location in accordance with manufacturer's equipment specifications, bid specifications and SBBC policies and procedures. Installation shall include equipment set up, leveling, and installation of accessories, shelves, factory start-up and training. Final electrical, plumbing and gas hook-ups shall be done by SBBC personnel.
- D. All rubbish, refuse, scrap materials and debris as a result of Awardee's installation must be cleared from the site location on a daily basis by the Awardee/installer. No rubbish, refuse or scrap materials as a result of installation shall be placed in SBBC dumpsters. Leave the work site clean and free of any debris at the end of each work day.
- E. At completion of installation, the site shall be in a ready-to-use condition, free of debris. Restore site to its original condition.

- 16. PLACEMENT, SET-UP AND INSTALLATION:** Awardee(s) shall be responsible for inside delivery, setting in place, connecting separate items, removing cartons, installing refrigerator and warmer shelves, plug-in and remove tape when necessary. All tables, shelves, racks, etc. must be delivered completely assembled. Level equipment where necessary is required. When necessary, sealing and caulking to the floor must be completed upon delivery. No electrical or plumbing hook-ups are required with the exception of ice machines. Ice machine price is to include disconnecting the existing ice machine and slide out of way and hook up of new machine to existing utilities. Do not remove any school board owned equipment from the premises.

The Food and Nutrition Services Department must be notified 72 hours in advance of delivery so that School Board electricians and plumbers can be notified and so that existing equipment can be disconnected and removed prior to vendor's arrival.

PLACEMENT, SET-UP AND INSTALLATION (FOR BID ITEMS 30): Awardee(s) shall be responsible for inside delivery, setting in place and connecting separate items. No electrical or plumbing hook-up is required. The installation should include, but not be limited to, removing tape, installing sneeze guards, tray rails, display cases, and other parts shipped separately, and removing and disposing all shipping materials. Awardee(s) must attach and level all separate pieces and leave serving line equipment ready for use. Awardee(s) is/are not responsible for final electrical and plumbing connections. Installation shall be completed on the same day of delivery. Factory start-up is required on all kettles, ovens, steamers, and combi-steamers.

- 17. PROTECTION OF PROPERTY:** The Awardee shall at all times guard against damage and/or loss to the property of SBBC, and shall replace and/or repair any loss or damages unless such is caused by the SBBC. SBBC may withhold payment or make such deductions, as it might deem necessary to insure reimbursement for loss and/or damages to the property through negligence of the Awardee.

SECTION 6 - BID SPECIFICATIONS (CONTINUED)

In order to be considered for award, Bidders must fill these Bid Specifications Forms and the Electronic Bid Summary Sheet and submit them with their bid, in time for bid opening.

ITEM 15 – TO BE AWARDED AS A GROUP

Item #

15A SAP Number: 6000813

Item Name: REFRIGERATOR, TWO-DOOR, TWO SECTION

Description: Construction to be stainless steel exterior door, front, sides, & interior floor. Aluminum interior side walls and back. 20 gauge stainless steel door & door interior. Foamed-in-Place Polyurethane Insulation throughout. Front shroud to lift up for easy access to clean condenser coil. Refrigeration to be R-134a or R290 where available. Top mount refrigeration system. Exterior digital temperature display; automatic LED lighting with door switch. Durable removable snap-in magnetic gasket. Self-closing door with stay open feature. Lifetime guarantee on door handle and cam-lift door hinges. Heavy duty cylinder or bolt locks with lifetime warranty. One door to have three (3) heavy-duty, epoxy coated or chrome shelves. One door complete with a minimum of 9 sets of universal tray/pan slides on 4" centers to accept bottom support 18" x 26" pans. All condensate water is disposed of automatically by the energy efficient, non-electric condensate evaporator. Condenser coil to be out of food zone. If expansion valve system Compressor to have high-pressure cut-off switch. If a capillary tube system then system must be oversized and balanced for quick recovery and pull down. Maintains temperatures of 33 degrees – 38 degrees. Inside storage capacity to be a minimum of 46 useable cubic feet. Heavy-duty 5" polyurethane plate casters, two with brakes. Size: Maximum height 84-1/4" on wheels, depth 35", length 52-53". 115V/60Hz/1 phase, amp draw not to exceed 11.0 with 9' or 10' Nema 5-15P cord/cap. NSF and UL approved.

Warranty: Three year manufacturer’s warranty, all parts and labor, five years for compressor must be included in the unit price. Warranty on compressor to be completely handled by service company for 5 years.

Price to include uncrate, set in place, removal of cartons, installation of shelves and clips, pan slides and casters, plug in and make ready for use.

Must ship from factory within 4 weeks of receipt of purchase order.

Approved Brand: Victory Model RSA-2D-S1, TRUE STA2R-2S with 1 each kit #1 and 1 each kit #4 or other brands meeting bid specifications

Brand Offered: _____

Model Offered: _____

Warranty Period: _____

Delivery (days ARO): _____

SECTION 6 - BID SPECIFICATIONS (CONTINUED)

In order to be considered for award, Bidders must fill these Bid Specifications Forms and the Electronic Bid Summary Sheet and submit them with their bid, in time for bid opening.

ITEM 15 – TO BE AWARDED AS A GROUP - CONTINUED

Item #

15B SAP Number: 6000814

Item Name: REFRIGERATOR, THREE-DOOR, THREE SECTION

Description: Construction to be stainless steel exterior door, front, sides, & interior floor. Aluminum interior side walls and back. 20 gauge stainless steel door & door interior liner. Front shroud to lift up for easy access to clean condenser coil. Refrigeration to be R-134a or R290 where available, foamed-in-place polyurethane insulation throughout. Top mount refrigeration system. Exterior digital temperature display; automatic LED interior light with door switch. Durable removable magnetic snap-in gasket with 2 year warranty. Self-closing door with stay open feature. Lifetime guarantee on door handle and cam-lift door hinges. Heavy duty cylinder or bolt locks with lifetime warranty. Two doors to have three (3) heavy-duty, epoxy coated or chrome shelves. One door complete with a minimum of 9 sets of universal tray/pan slides on 4" centers to accept bottom support 18" x 26" pans. All condensate water is disposed of automatically by the energy efficient, non-electric condensate evaporator. Condenser coil to be out of food zone. If expansion valve system, Compressor to have high-pressure cut-off switch. If a capillary tube system, then system must be oversized and balanced for quick recovery and pull down. Inside storage capacity to be a minimum of 70.09 useable cubic feet. Refrigerator to include the following options: heavy-duty 5" polyurethane plate casters, two with brakes, Maximum height 84-1/4" on casters, max. depth 35". Length 76-78". 115V/60Hz/1 phase, amp draw not to exceed 11.0 with 9' or 10' Nema 5-15P cord/cap. NSF and UL approved.

Warranty: Three year manufacturer’s warranty, five years for compressor must be included in the unit price. Warranty on compressor to be completely handled by service company for 5 years.

Price to include uncrate, set in place, removal of plastic and cartons, installation of shelves and clips, plug in, and make ready for use.

Must ship from factory within 4 weeks of receipt of purchase order.

Approved Brands: Victory Model RSA-3D-S1, TRUE STA3R-3S with 2 each kit #4 and 1 each kit #1 or other brands meeting bid specifications

Brand Offered: _____

Model Offered: _____

Warranty Period: _____

Delivery (days ARO): _____

SECTION 6 - BID SPECIFICATIONS (CONTINUED)

In order to be considered for award, Bidders must fill these Bid Specifications Forms and the Electronic Bid Summary Sheet and submit them with their bid, in time for bid opening.

Item #

19 SAP Number: 6000810

Item Name: FREEZER, REACH-IN, SELF-CONTAINED, THREE DOOR

Description: Freezer construction to be heavy gauge polished stainless steel exterior door, front, sides, & interior floor. Aluminum interior side walls and back. 20 gauge stainless steel door. Unit must have reinforced 20 gauge bottom to withstand heavy loads. Foamed-in-Place Polyurethane Insulation throughout. Front shroud to lift up for easy access to clean condenser coil. Maintains temperatures of 0 to 5 degrees in ambient temperatures of up to 100 degrees. Refrigeration to be R-404a or R290 where available. Top mount refrigeration system with expansion valve. Capacity: minimum 70 cu. ft. of usable space. Heavy duty 5" polyurethane plate casters, 2 with brakes. Each compartment shall have a stainless steel floor rack. Self-closing door with stay-open feature. Cam-lift hinges with safety stop at 120 degrees. Heavy duty cylinder or bolt locks. Electronic controller with exterior digital temperature display; automatic LED lighting with door switch. Durable removable magnetic snap-in gasket. Anti-condensate door perimeter heaters concealed with high-impact non-conductive thermal breaker.

Non-electric condensate evaporator top mounted that disposes of water automatically with pan of sufficient size to accommodate condensation. No plumbing required. Power supply at top. Provide evaporator coil out of food zone.

Furnished with nine heavy-duty epoxy coated shelves, three per door to accommodate 18" x 26" sheet pans in each full door. Size: Maximum height 84-1/4" high, max. depth 35", length 76 - 78". Electrical: 208/-230/60/1, not to exceed 13.0 AMPS. Condensing unit 3/4 HP. Unit to be NSF and UL listed.

Warranty: Three year manufacturer's warranty on all parts and labor plus warranty against condensation build up, five year warranty parts and labor on compressor must be included in the unit price. Warranty on compressor to include shipping and pick up of old compressor upon phone call to factory.

Set-up will include installation of shelves and clips and installation of wheels. Uncrated and remove crate. Unit must be shipped with parts manual and schematics to each location.

Approved Brand: Victory Model FSA-3D-S1 or other brands meeting bid specifications

Brand Offered: _____

Model Offered: _____

Warranty Period: _____

Delivery (days ARO): _____

SECTION 6 - BID SPECIFICATIONS (CONTINUED)

In order to be considered for award, Bidders must fill these Bid Specifications Forms and the Electronic Bid Summary Sheet and submit them with their bid, in time for bid opening.

Item #

20 SAP Number: 6000811

Item Name: FREEZER, REACH-IN, SELF-CONTAINED – TWO DOOR

Description: Freezer construction to be heavy-gauge polished stainless steel exterior door, front, sides, & interior floor. 20 gauge stainless steel door. Unit must have reinforced 20 gauge bottom to withstand heavy loads. Aluminum interior side walls and back. Foamed-in-Place Polyurethane Insulation throughout. Front shroud to lift up for easy access to clean condenser coil. Maintains temperatures of 0 to 5 degrees in ambient temperatures of up to 100 degrees. Refrigeration to be R-404a or R290 where available. Top mount refrigeration system with expansion valve. Capacity: minimum 46.5 cu. ft. of usable space. Heavy duty 5" polyurethane plate casters, 2 with brakes. Each compartment shall have a stainless steel floor rack.

Self-closing door with stay open feature. Cam-lift hinges with safety stop at 120 degrees. Heavy duty cylinder or bolt locks. All doors keyed alike. Electronic controller with exterior digital temperature display; automatic LED lighting with door switch. Durable removable magnetic snap-in gasket. Breaker strips shall leave no exposed electrical heating elements and securely installed around entire perimeter of front frame and mullions of all door openings. Anti-condensate door perimeter heaters.

Non-electric condensate evaporator top mounted that disposes of water automatically with pan of sufficient size to accommodate condensation. No plumbing required. Power supply at top. Provide evaporator coil out of food zone.

Furnish with six heavy-duty epoxy coated shelves, to-accommodate 18" x 26" pans, three per door. Size: Maximum height 84-1/4" high on wheels, max. depth 35", length 52 – 53". Electrical: 115/60/1, not to exceed 12 AMPS. 1/2 or 3/4 HP condensing unit. Unit to be NSF and UL listed.

Warranty: Three year manufacturer's warranty on all parts and labor plus warranty against condensation build up, five year warranty on compressor must be included in the unit price. Set-up will include installation of shelves and clips and installation of wheels. Uncrate, set-in place, remove all cartons. Unit must be shipped with parts manual and schematics to each location.

Approved Brands: Victory Model FSA-2D-S1 or other brands meeting bid specifications

Brand Offered: _____

Model Offered: _____

Warranty Period: _____

Delivery (days ARO): _____

SECTION 6 - BID SPECIFICATIONS (CONTINUED)

In order to be considered for award, Bidders must fill these Bid Specifications Forms and the Electronic Bid Summary Sheet and submit them with their bid, in time for bid opening..

ITEM 42 – TO BE AWARDED AS A GROUP

Item #

42A SAP Number: 6000803
Item Name: AUTOMATIC ICE MAKING MACHINE, 368 LBS. MINIMUM
Description: (330 lbs.) Modular air cooled ice maker, ARI standard minimum of 368 lbs. at 90° air and 70° water. Medium ice cube size – 7/8" x 7/8" x 7/8". Corrosion-resistant stainless steel exterior. No air filter or front located air filter. 115/60/1 electric requirements only. 30" wide. Air cooled. Complete with factory approved water filter. WARRANTY: 3 year parts and labor on all components; 5-7 year parts & labor on evaporator; 5 year parts on compressor, condenser.
Note: Unit price shall include installation, set up, placement, shipping, free warranty service calls while machine under warranty, start-up, parts manual. SBBC shall supply existing water line, electric outlets, and drainage.
MUST BE ENERGY STAR RATED
Approved Brands:
Scotsman C0530SA-1A, Manitowac ID0502-A, Ice-O-Matic ICE0400A, Hoshizaki KM-515MAH ONLY.

Brand Offered: _____
Model Offered: _____
Warranty Period: _____
Delivery (days ARO): _____

Item #

42B SAP Number: 6000804
Item Name: BIN, 500 LBS. MINIMUM
Description: To be compatible with Item A. Holds minimum 500 lbs. Front door and sides of bin to be stainless steel or polyethylene exterior. 6" adjustable legs. Foamed-in-place polyurethane insulation. Non-corrosive polyliner. NSF and UL listed.
WARRANTY: 3 year parts and labor.

Approved Brands:
Scotsman B530P, Ice-O-Matic B55, Hoshizaki B-500 SF, Manitowac B-570 ONLY

Brand Offered: _____
Model Offered: _____
Warranty Period: _____
Delivery (days ARO): _____



PROCUREMENT & WAREHOUSING SERVICES

MARY CATHERINE COKER, DIRECTOR

www.BrowardSchools.com

The School Board of
Broward County, Florida

Abby M. Freedman, Chair
Nora Rupert, Vice Chair

Robin Bartleman
Heather P. Brinkworth
Donna P. Korn
Patricia Good
Laurie Rich Levinson
Ann Murray
Dr. Rosalind Osgood

Robert W. Runcie
Superintendent of Schools

June 28, 2017

Dear Prospective Bidders,

**SUBJECT: Instructions to Bidders
Invitation to Bid: 18-027B CAFETERIA EQUIPMENT**

The School Board of Broward County, Florida (SBBC) is interested in receiving bids in response to the attached Invitation to Bid (ITB) for **Cafeteria Equipment**. Any questions regarding this ITB should be addressed to me, in writing, at the address stated above, via facsimile at 754-321-0533 or via e-mail to Larissa.Seda@browardschools.com.

No other School Board staff member should be contacted in relation to this ITB. Any information that amends any portion of this ITB, which is received by any method other than an Addendum issued to the ITB, is not binding on SBBC.

In order to assure that your bid is in full compliance with all requirements of the ITB, carefully read all portions of the ITB document, paying particular attention to the following areas:

• **MINORITY/WOMEN BUSINESS ENTERPRISE (M/WBE) CERTIFICATION/PARTICIPATION (See EXHIBIT A1 AND A2)**
SBBC has implemented a Minority/Women Business Enterprise (M/WBE) Program as part of the SBBC's competitive solicitation and contracting activity in accordance with School Board Policy 7007-A Administrative Procedures for The School Board of Broward County, Florida's Supplier Diversity & Outreach Program. The purpose of the program is to utilize available minority and women businesses within the Board's market area to compete for the award of SBBC construction and purchasing contracts. M/WBE vendors utilized for this contract must be certified by SBBC's Supplier Diversity & Outreach Program Office prior to submission of bid proposal. **For information on M/WBE Certification, contact SBBC's Supplier Diversity & Outreach Program at 754-321-0550 or visit <http://www.browardschools.com/sdop>.**

- **SECTION 2, SUBMITTAL REQUIREMENTS**
Section 2, Submittal Requirements, is a listing of all submittals that are required to be part of your bid package. Please make sure that all required submittals have been included as part of your bid package.
- **COMPLETION OF BIDS**
The Bid Summary Sheets upon which the Bidder submits its prices shall be completed in excel. **The Bidder Acknowledgement Section should be completed in full and fully executed by an authorized representative of the Bidder.** SBBC reserves the right to reject any bid which is not completed in full.
- **PRICING CORRECTIONS**
If a price correction is necessary on the Bid Summary Sheet, update the excel spreadsheet. SBBC reserves the right to not tabulate any illegible entries, pencil bids or price corrections not initialed and to reject any bid containing any of these errors.
- **DUE DATE**
Bids are due in Procurement and Warehousing Services on the date and time stated on Page 1 of the ITB. In order to have your bid considered, it must be received on or before the date and time due. Bids received after 2:00 p.m. ET on date due will not be considered.
- **STATEMENT OF "NO BID"**
If you are **not** submitting a bid in response to this ITB, please complete Section 8, Statement of "No Bid" and return via facsimile to 754-321-0533 or scan and send via e-mail to Larissa.Seda@browardschools.com. Your response to the Statement of "No" Bid is very important to Procurement and Warehousing Services when creating future ITBs.

Thank you for your interest in SBBC. Again, if you have any questions, please contact me at the telephone number or email address stated above.

Larissa Seda
Purchasing Agent II

TABLE OF CONTENTS

INVITATION TO BID	1
SECTION 3, GENERAL CONDITIONS	2
SECTION 4, SPECIAL CONDITIONS	8
SECTION 5, BID SUMMARY SHEET.....	14
SECTION 6, BID SPECIFICATIONS	16
SECTION 7, FORMS AND ATTACHMENTS.....	162
ATTACHMENT 1	163
DISCLOSURE OF POTENTIAL CONFLICT OF INTEREST AND CONFLICTING EMPLOYMENT OR.....	163
CONTRACTUAL RELATIONSHIP	163
ATTACHMENT 2	164
DRUG FREE WORKPLACE	164
ATTACHMENT 3	165
MINIMUM LIMITS OF INSURANCE REQUIREMENTS	165
ATTACHMENT 4	166
LEGAL OPINION OF BIDDER'S PREFERENCE	166
ATTACHMENT 5	167
W-9 Form	167
ATTACHMENT 6	168
ACH Payment Agreement Form (ACH CREDITS).....	168
SECTION 8, STATEMENT OF "NO BID".....	169
EXHIBIT A1	170
MINORITY/WOMEN BUSINESS ENTERPRISE (M/WBE).....	170
PARTICIPATION FORM	170
Exhibit A2	171
Monthly M/WBE Subcontractor Utilization Report.....	171
EXHIBIT B.....	172
CERTIFICATION OF DEBARMENT, SUSPENSION, INELIGIBILITY AND VOLUNTARY EXCLUSION	172
LOWER TIER TRANSACTIONS.....	172
EXHIBIT B.....	173
INSTRUCTIONS FOR CERTIFICATION	173



The School Board of Broward County, Florida
PROCUREMENT AND WAREHOUSING SERVICES
 7720 West Oakland Park Boulevard, Suite 323
 Sunrise, Florida 33351-6704
 754-321-0505

INVITATION TO BID (ITB)

DUE DATE: Bids due on or before 2:00 p.m. Eastern Time (ET) at Procurement & Warehousing Services:
AUGUST 2, 2017

ITB NO.:
18-027B

RELEASE DATE:
JUNE 28, 2017

PURCHASING AGENT:
Larissa Seda
754-321-0524

Check Addenda for any revised opening dates before submitting your bid. **Bid(s) received, after the date and time stated above, shall not be considered for award.** Faxed bids are not allowed and will not be considered for award.

BID TITLE:
CAFETERIA EQUIPMENT

SECTION 1 – Bidder Acknowledgement

IN ACCORDANCE WITH GENERAL CONDITION 1, THIS SECTION MUST BE COMPLETED IN ITS ENTIRETY INCLUDING THE SIGNATURE OF AN AUTHORIZED REPRESENTATIVE WHERE INDICATED BELOW AND SUBMITTED WITH THE BID. FAILURE TO PROVIDE THIS DOCUMENT, WITH THE BID, WILL RESULT IN BID BEING CONSIDERED NON-RESPONSIVE.

Bidder's Name and state "Doing Business As", where applicable:	"REMIT TO" ADDRESS FOR PAYMENT: If payment(s) is/are to be mailed to address other than as stated on left, please complete section below. <input type="checkbox"/> Check this box if address is the same as stated on the left.
Address:	P.O. Address:
City:	
State: Zip Code:	City:
Telephone Number:	State: Zip Code:
Toll Free Number:	Contact:
Fax Number:	Telephone Number:
E-Mail Address of Authorized Representative:	Toll Free Number:
E-mail Address to Send Purchase Orders:	Fax Number:
Federal Tax Identification Number:	

I hereby certify that: I am submitting the following information as my firm's (Bidder) bid and am authorized by Bidder to do so. Bidder agrees to complete and unconditional acceptance of the contents of all pages in this Invitation To Bid (ITB), and all appendices and the contents of any Addenda released hereto; Bidder agrees to be bound to any and all specifications, terms and conditions contained in the ITB, and any released Addenda and understand that the following are requirements of this ITB and failure to comply will result in disqualification of bid submitted; Bidder has not divulged, discussed, or compared the bid with other Bidders and has not colluded with any other Bidder or party to any other bid; Bidder, its principals, or their lobbyists has not offered campaign contributions to School Board Members or offer contributions to School Board Members for campaigns of other candidates for political office during the period in which the Bidder is attempting to sell goods or services to the School Board. This period of limitation of offering campaign contributions shall commence at the time of the "cone of silence" period for any solicitation for a competitive procurement as described by School Board Policy 3320, Part II, Section GG as well as School Board Policy 1007, Section 5.4 – Campaign Contribution Fundraising. Bidder acknowledges that all information contained herein is part of the public record as defined by the State of Florida Sunshine and Public Records Laws; all responses, data and information contained in this bid are true and accurate.
 I agree that this bid cannot be withdrawn within 90 days from date due.

Signature of Authorized Representative (Manual)

Name of Authorized Representative (Typed or Printed)

Title

SECTION 2 – Submittal Requirements

SUBMITTAL REQUIREMENTS: In order to assure that your bid is in compliance with bid requirements, please verify that the submittals indicated by the below have been submitted.

- | | | | |
|--------------------------------------------------------------------------------------------------------|--------------------------------------------------------------------------------------------------------|----------------------------------------------------------------------------------------------------|------------------------------------------------------------------------------|
| <input type="checkbox"/> Bid Bond
Special Condition __ | <input checked="" type="checkbox"/> Bid Specifications
Section 6 | <input checked="" type="checkbox"/> M/WBE Participation
Exhibit A | <input type="checkbox"/> Material Safety Data Sheets
Special Condition __ |
| <input type="checkbox"/> Manufacturers Authorization
Special Condition __ | <input checked="" type="checkbox"/> Conflict of Interest Form
Section 7, Attachment 1 | <input checked="" type="checkbox"/> Certificate of Debarment
General Condition 45 | <input type="checkbox"/> Other _____
Special Condition __ |
| <input checked="" type="checkbox"/> Bidder's Preference Statement
Special Condition 6 | <input checked="" type="checkbox"/> Electronic Bid Summary Sheet
(.xls file) | | |

Note: If your firm wishes to not submit a bid in response to the ITB, please complete and return, via mail or fax, the Statement of No Bid attached as the last page of this ITB.

SECTION 3, GENERAL CONDITIONS

1. **SEALED BID REQUIREMENTS:** The "Bidder Acknowledgement Section" must be completed, signed and returned with the bid. The Bid Summary Sheet pages on which the Bidder actually submits a bid, and any pages, upon which information is required to be inserted, must be completed and submitted with the bid. **The School Board of Broward County (SBBC) reserves the right to reject any bid that fails to comply with these submittal requirements.**
 - a) **BIDDER'S RESPONSIBILITY:** It is the responsibility of the Bidder to be certain that all numbered pages of the bid and all attachments thereto are received and all Addendum released are received prior to submitting a bid without regard to how a copy of this ITB was obtained. All bids are subject to the conditions specified herein on the attached bid documents and on any Addenda issued thereto.
 - b) **BID SUBMITTED:** Completed bid must be submitted in a sealed envelope with bid number and name clearly typed or written on the front of the envelope. Bids must be time stamped in Procurement and Warehousing Services **on or before 2:00 p.m. ET on date due** for bid to be considered. Bids shall be opened at 2:00 p.m. ET on date due. Bids submitted by telegraphic or facsimile transmission shall not be accepted.
 - c) **EXECUTION OF BID:** Bid must contain an original manual signature of an authorized representative in the space provided above. All bids must be completed in ink or typewritten. **If a price correction is necessary, draw a single line through the entered figure and enter the corrected figure or use an opaque correction fluid. All price corrections must be initialed by the person signing the bid even when using opaque correction fluid.** SBBC reserves the right to reject any bid or bid item completed in pencil or any bid that contains illegible entries or price corrections not initialed.
 - d) **BIDDING PREFERENCE LAWS: ALL BIDDERS MUST COMPLETE AND SUBMIT THE LEGAL OPINION OF BIDDER'S PREFERENCE FORM IN ORDER TO BE CONSIDERED FOR AWARD.** The State of Florida provides a Bidder's preference for Florida vendors for the purchase of personal property. The local preference is five (5) percent. Bidders outside the State of Florida must have an Attorney, licensed to practice law in the out-of-state jurisdiction, as required by Section 2, Chapter 287.084, Florida Statutes, execute the "Opinion of Out-of-State Bidder's Attorney on Bidding Preferences" form and must submit this form with the submitted bid. Such opinion should permit SBBC's reliance on such attorney's opinion for purposes of complying with Chapter 287.084, Florida Statutes. Florida Bidders must also complete its portion of the form. Failure to submit and execute this form, with the bid, shall result in bid being considered "non-responsive" and bid rejected.
 2. **PRICES QUOTED:** Deduct trade discounts and quote firm net prices. Give both unit price and extended total. Prices must be stated in units to quantity specified in the bidding specification. In case of discrepancy in computing the amount of the bid, the **Unit Price** quoted shall govern.

All prices quoted shall be F.O.B. destination and freight prepaid (Bidder pays and bears freight charges). Awardee owns goods in transit and files any claims. Discounts for prompt payment: Award, if made, shall be in accordance with terms and conditions stated herein. Each item must be bid separately and no attempt is to be made to tie any item or items in with any other item or items. **Cash or quantity discounts offered shall not be a consideration in determination of award of bid(s).** If an Awardee offers a discount or offers terms less than Net 30, it is understood that a minimum of 30 days shall be required for payment, and if a payment discount is offered, the discount time shall be computed from the date of satisfactory delivery at place of acceptance and receipt of correct invoice at the office specified.

 - a) **TAXES:** SBBC does not pay Federal Excise and State taxes on direct purchase of tangible personal property. The applicable tax exemption number is shown on the Purchase Order. This exemption does not apply to purchases of tangible personal property made by contractors who use the tangible personal property in the performance of contracts for the improvement of SBBC owned real property as defined in Chapter 192, Florida Statutes.
 - b) **MISTAKES:** Bidders are expected to examine the specifications, delivery schedules, bid prices and extensions, and all instructions pertaining to supplies and services. Failure to do so shall be at Bidder's risk.
 - c) **CONDITION AND PACKAGING:** It is understood and agreed that any item offered or shipped as a result of this bid shall be new (current production model at the time of this bid) unless otherwise specified. All containers shall be suitable for storage or shipment and all prices shall include standard commercial packaging.
 - d) **UNDERWRITERS' LABORATORIES:** Unless otherwise stipulated in the Bid, all manufactured items and fabricated assemblies shall be UL listed where such has been established by UL for the item(s) offered and furnished. In lieu of the UL listing, Bidder may substitute a listing by an independent testing laboratory recognized by OSHA under the Nationally Recognized Testing Laboratories (NRTL) Recognition Program.
- e) **BIDDER'S CONDITIONS:** Bid conditions and specifications **shall not** be changed, altered or conditioned in any way. SBBC specifically reserves the right to reject any conditional bid.
 3. **SAMPLES:** Samples of items, when required, must be furnished free of expense within five (5) working days of request unless otherwise stated and, if not destroyed, will, upon request, be returned at the Bidder's expense. Bidders shall be responsible for the removal of all samples furnished within 30 days after bid opening. All samples shall be disposed of after 30 days. Each individual sample must be labeled with Bidder's name, bid number and item number. Failure of Bidder to either deliver required samples or to clearly identify samples as indicated may be reason for rejection of the bid item. Unless otherwise indicated, samples should be delivered to Procurement and Warehousing Services, The School Board of Broward County, Florida, 7720 West Oakland, Park Boulevard, Suite 323, Sunrise, Florida 33351-6704.
 4. **DELIVERY:** All deliveries shall be F.O.B. destination point. Unless actual date of delivery is specified (or if specified delivery cannot be met), show number of days required to make delivery after receipt of Purchase Order in space provided. Delivery time may become a basis for making an award (see Special Conditions). Delivery shall be within the normal working hours of the user, Monday through Friday, excluding state holidays and days during which SBBC administration is closed.
 5. **INTERPRETATIONS:** Any questions concerning conditions and specifications must be submitted in writing and received by Procurement and Warehousing Services no later than **ten working days, or as stated in the Special Conditions**, prior to the original bid opening date. If necessary, an Addendum shall be issued.
 6. **AWARDS:** In the best interest of SBBC, SBBC reserves the right to: 1) withdraw this ITB at any time prior to the time and date specified for the bid opening; 2) to reject any or all bids received when there are sound documented business reasons that serve the best interest of SBBC; 3) to accept any item or group of items unless qualified by Bidder; and 4) to acquire additional quantities at prices quoted on this ITB unless additional quantities are not acceptable, in which case, the bid sheets must be noted "BID IS FOR SPECIFIED QUANTITY ONLY." All awards made as a result of this bid shall conform to applicable Florida Statutes and shall be governed by the laws of the State of Florida, and must have venue established in the 17th Judicial Circuit Court of Broward County, Florida or the United States Court of the Southern District of Florida.
 7. **BID OPENING:** Shall be public, on the date and at the time specified on the bid form. All bids received after that time shall not be considered.
 8. **ADVERTISING:** In submitting a bid, Bidder agrees not to use the results there from as a part of any commercial advertising without prior approval of SBBC.
 9. **INSPECTION, ACCEPTANCE & TITLE:** Inspection and acceptance shall be at destination unless otherwise provided. Title to/ or risk of loss or damage to all items shall be the responsibility of the Awardee until acceptance by the buyer unless loss or damage resulting from negligence by the buyer. If the materials or services supplied to SBBC are found to be defective or not conform to specifications, SBBC reserves the right to cancel the order upon written notice to the seller and return product at Awardee's expense.
 10. **PAYMENT:** Payment shall be made by SBBC after the items awarded have been received, inspected, found to comply with award specifications and free of damage or defect and properly invoiced. All payments shall be made by ACH (Automated Clearing House) for automatic deposits (credits).
 11. **CONFLICT OF INTEREST AND CONFLICTING EMPLOYMENT OR CONTRACTUAL RELATIONSHIP:** Section 112.313 (3) and (7), Florida Statutes, sets forth restrictions on the ability of SBBC employees acting in a private capacity to rent, lease, or sell any realty, goods or services to SBBC. It also places restrictions on SBBC employees concerning outside employment or contractual relationships with any business entity which is doing business with SBBC. Each Bidder is to disclose any employees it has who are also SBBC employees by submitting Attachment 1, Disclosure of Potential Conflict of Interest and Conflicting Employment or Contractual Relationship, with its Bid. Any employees identified by the Bidder when completing Attachment 1 should obtain legal advice as to their obligations and restrictions under Section 112.313 (3) and (7), Florida Statutes.
 12. **INSURANCE:** Bidder, by virtue of submitting a bid, shall be in full compliance with paragraph 20: LIABILITY INSURANCE, LICENSES AND PERMITS of the General Conditions. Insurance Requirements are shown in FORMS AND ATTACHMENTS Section of this ITB. Bidder shall take special notice that SBBC shall be named as an additional insured under the General Liability policy including Products Liability.

The insurance policies shall be issued by companies qualified to do business in the State of Florida. The insurance companies must be rated at least A-VI by AM Best or Aa3 by Moody's Investor Service. All policies must remain in effect during the performance of the contract.

13. **LICENSES, CERTIFICATIONS AND REGISTRATIONS:** As of the Bid Opening Date, Bidder must have all Licenses, Certifications and Registrations required when performing the services as described herein, in order for Bid to be considered a responsive and responsible Bid. Licenses, Certifications and Registrations required for this Bid shall be as required by Chapter 489, Florida Statutes, as currently enacted or as amended from time to time; by the State Requirements for Educational Facilities (SREF), latest version; and by Broward County, Florida. Bidder must submit a copy of all its current Licenses, Certifications and Registrations required as described herein, either with its Bid or within five working days of notification.
- An Awardee who has any License, Certification or Registration either suspended, revoked or expired after the date of the Bid Opening, shall provide notice to the Director of Procurement & Warehousing Services within five working days of such suspension, revocation or expiration. However, such suspension, revocation or expiration after the date of the Bid Opening shall not relieve the Awardee of its responsibilities under this ITB.*
14. **PATENTS & ROYALTIES:** The Awardee, without exception, shall indemnify and save harmless SBBC and its employees from liability of any nature or kind, including cost and expenses for any copyrighted, patented, or unpatented invention, process, or article manufactured or used in the performance of the contract, including its use by SBBC. If the Awardee uses any design, device, or materials covered by letters, patent, or copyright, it is mutually understood and agreed without exception that the bid prices shall include all royalties or cost arising from the use of such design, device or materials in any way involved in the work.
15. **OSHA:** The Awardee warrants that the product supplied to SBBC shall conform in all respects to the standards set forth in the Occupational Safety and Health Act of 1970, as amended, and the failure to comply with this condition shall be considered as a breach of contract.
16. **SPECIAL CONDITIONS:** The Superintendent or Designee has the authority to issue Special Conditions and Specifications as required for individual bids. Any and all Special Conditions that may vary from these General Conditions shall have precedence.
17. **ANTI-DISCRIMINATION:** SBBC, prohibits any policy or procedure which results in discrimination on the basis of age, color, disability, gender identity, gender expression, national origin, marital status, race, religion, sex or sexual orientation. Individuals who wish to file a discrimination and/or harassment complaint may call the Executive Director, Benefits, Employment Services and EEO Compliance at 754-321-2150 or Teletype Machine TTY 754-321-2158.
18. **QUALITY:** All materials used for the manufacture or construction of any supplies, materials or equipment covered by this bid shall be new unless otherwise specified. The items bid must be new, the latest model, of the best quality and highest grade workmanship.
19. **LIABILITY INSURANCE, LICENSES AND PERMITS:** Where Awardees are required to enter or go onto SBBC property to deliver materials or perform work or services as a result of a bid award, the Awardee agrees to The Hold Harmless Agreement stated herein and shall assume the full duty obligation and expense of obtaining all necessary licenses, permits and insurance. The Awardee shall be liable for any damages or loss to SBBC occasioned by negligence of the Awardee (or agent) or any person the Awardee has designated in the completion of the Contract as a result of their bid.
20. **BID BONDS, PERFORMANCE BONDS AND CERTIFICATES OF INSURANCE:** Bid bonds, when required, shall be submitted with the bid in the amount specified in Special Conditions. Bid bonds shall be returned to non-Awardees. After acceptance of bid, SBBC shall notify the Awardee to submit a performance bond and certificate of insurance in the amount specified in Special Conditions. Upon receipt of the performance bond, the bid bond shall be returned to the Awardee.
21. **CANCELLATION:** In the event any of the provisions of this bid are violated by the Awardee, the Superintendent shall give written notice to the Awardee stating the deficiencies and unless deficiencies are corrected within five days, recommendation shall be made to SBBC for immediate cancellation.
22. **IRREVOCABILITY OF BID:** A bid may not be withdrawn before the expiration of 90 days from the date of bid opening.
23. **INFORMATION NOT IN ITB:** No verbal or written information which is obtained by a Bidder other than by information within this document or Addenda to this ITB shall be binding on SBBC.
24. **EXPENDITURE:** No guarantee is given or implied as to any sums payable or the quantity or scope of any award under this ITB. SBBC is not obligated to place any order for goods/services as a result of this award. Order placement shall be based upon the needs and best interest of SBBC.
25. **BILLING INSTRUCTIONS:** Invoices, unless otherwise indicated, must show Purchase Order numbers and shall be submitted in duplicate to The School Board of Broward County, Florida, Accounting and Financial Reporting Department, Attn: Accounts Payable, 600 S.E. 3rd Avenue, 7th Floor, Fort Lauderdale, Florida 33301. (Unless otherwise stated in the Special Conditions) Payment shall be made a minimum of 30 days after delivery, authorized inspection and acceptance. When vendors are directed to send invoices to a school, the school shall make direct payments to the vendor.
26. **NOTE TO VENDORS DELIVERING TO MATERIALS LOGISTICS CENTRAL (WAREHOUSE):** Receiving hours are Monday through Friday (excluding state holidays and days during which SBBC administration is closed) **7:00 a.m. to 2:00 p.m. ET.**
27. **SUBSTITUTIONS:** SBBC *SHALL NOT* accept substitute shipments of any kind. Awardees are expected to furnish the brand quoted in their bid once awarded by SBBC. Any substitute shipments shall be returned at the Awardee's expense.
28. **FACILITIES:** SBBC reserves the right to inspect the Awardee's facilities at any time with prior notice. SBBC may use the information obtained from this in determining whether a Bidder is a responsible Bidder.
29. **ASBESTOS AND FORMALDEHYDE STATEMENT:** All building materials, pressed boards, and furniture supplied to SBBC shall be **100% asbestos free. It is desirous that all building materials, pressed boards and furniture supplied to SBBC also be 100% formaldehyde free.** Bidder, by virtue of bidding, certifies by signing bid that, if awarded this bid, only building materials, pressed boards, and/or furniture that is **100% asbestos free** shall be supplied.
30. **ASSIGNMENT:** Neither any award of this bid nor any interest in any award of this bid may be assigned, transferred or encumbered by any party without the prior written consent from the Director, Procurement and Warehousing Services. There shall be no partial assignments of this ITB including, without limitation, the partial assignment of any right to receive payments from SBBC.
31. **EXTENSION:** In addition to any extension options contained herein, SBBC is granted the right to extend any award resulting from this bid for the period of time necessary for SBBC to release, award and implement a replacement bid for the goods, products and/or services provided through this bid. Such extension shall be upon the same prices, terms and conditions as existing at the time of SBBC's exercise of this extension right. The period of any extension under this provision shall not be for a period in excess of six months from (a) the termination date of a contract entered into as a result of this bid or (b) the termination date under any applicable period of extension under a contract entered into as a result of this bid.
32. **OMISSION FROM THE SPECIFICATIONS:** The apparent silence of this specification and any Addendum regarding any details or the omission from the specification of a detailed description concerning any point shall be regarded as meaning that only the best available units shall be provided and the best commercial practices are to prevail, and that only materials and workmanship of first quality are to be used. All interpretations of this specification shall be made upon the basis of this agreement.
33. **SUBMITTAL OF INVOICES:** All Bidders are hereby notified that any invoice submitted as a result of the award of this bid must be in the same format as any Purchase Order released as a result of the award of this bid. **Each line of the invoice must reference a corresponding single line shown on the Purchase Order.** A single invoice line must not correspond to or commingle the cost shown on multiple Purchase Order lines. An invoice submitted that does not follow the same format and line numbering as shown on the Purchase Order shall be deemed to be not correct, and may be returned to the vendor by the Accounts Payable Department for correction. Address for submitting invoices is included on Purchase Order.
34. **PURCHASE AGREEMENT:** This bid and the corresponding Purchase Orders shall constitute the complete agreement. SBBC shall not accept proposed terms and conditions that are different than those contained in this Invitation to Bid, including pre-printed text contained on catalogs, price lists, other descriptive information submitted or any other materials. By virtue of submitting a bid, Awardee agrees to not submit to any SBBC employee, for signature, any document that contains terms and conditions that are different than those contained herein and that in the event any document containing any term or condition that differs from those contained herein is executed, said document shall not be binding on SBBC.
35. **SBBC INFORMATION SECURITY GUIDELINES:** It is the responsibility of the Awardee to read and adhere to the SBBC Information Security Guidelines when using any device connected to the SBBC's network. Following the conclusion of the contract term, all of SBBC's confidential information must be removed from Awardee's equipment and all access privileges must be revoked. Final payment shall be withheld until the Awardee has confirmed, in writing, that all SBBC's confidential information has been purged from any and all electronic technology devices that were used during this contract and were connected to the SBBC's network.

36. **PROTESTING OF BID CONDITIONS/SPECIFICATIONS:** Any person desiring to protest the conditions/specifications in this ITB, or any Addenda subsequently released thereto, shall file a notice of intent to protest, in writing, within 72 hours after electronic release of the competitive solicitation or Addendum and shall file a formal written protest within ten calendar days after the date the notice of protest was filed. Saturdays, Sundays, state holidays or days during which SBBC administration is closed shall be excluded in the computation of the 72 hours. If the tenth calendar day falls on a Saturday, Sunday, state holiday or day during which SBBC administration is closed, the formal written protest must be received on or before 5:00 p.m. ET of the next calendar day that is not a Saturday, Sunday, state holiday or day during which SBBC administration is closed. Section 3 b, Chapter 120.57, Florida Statutes, as currently enacted or as amended from time to time, states that **“The formal written protest shall state with particularity the facts and law upon which the protest is based.”**
- Failure to file a notice of protest or to file a formal written protest within the time prescribed by Section 3, Chapter 120.57, Florida Statutes, or a failure to post the bond or other security required by SBBC Policy 3320, within the time allowed for filing a bond, shall constitute a waiver of proceedings. The bond shall be conditioned upon the payment of all costs which may be adjudged against the protestant in an Administrative Hearing in which the action is brought and in any subsequent appellate court proceeding. In lieu of a bond, SBBC may accept a cashier's check, official bank check or money order in the amount of the bond. If, after completion of the Administrative Hearing process and any appellate court proceedings, SBBC prevails, SBBC shall recover all costs and charges which shall be included in the Final Order or judgment, including charges made by the Division of Administrative Hearings, but excluding attorney's fees. Upon payment of such costs and charges by the protestant, the bond shall be returned. The failure to post the bond required by SBBC Policy 3320, Part VIII, as currently enacted or as amended from time to time, shall constitute a waiver of proceedings. Notices of protest, formal written protests, and the bonds required by SBBC Policy 3320, shall be filed at the office of the Director, Procurement and Warehousing Services, 7720 West Oakland Park Boulevard, Suite 323, Sunrise, Florida 33351-6704 (fax 754-321-0936). Fax filing shall not be acceptable for the filing of bonds.
37. **POSTING OF BID RECOMMENDATIONS/TABULATIONS:** ITB Recommendations and Tabulations shall be posted in Procurement and Warehousing Services and on www.demandstar.com on **August 21, 2017 at 3:00 p.m. ET**, and shall remain posted for 72 hours. Any change to the date and time established herein for posting of ITB Recommendations/Tabulations shall be posted in Procurement and Warehousing Services and/or at www.demandstar.com (under the document section for this ITB). In the event the date and time of the posting of ITB Recommendations/Tabulations is changed, it is the responsibility of each Bidder to ascertain the revised date of the posting of ITB Recommendations/Tabulations. Any person desiring to protest the intended decision shall file a notice of protest, in writing, within 72 hours after the posting of the ITB tabulation and shall file a formal written protest within ten calendar days after the date the notice of protest was filed. Saturdays, Sundays, state holidays and days during which SBBC administration is closed shall be excluded in the computation of the 72 hours. If the tenth calendar day falls on a Saturday, Sunday, state holiday or day during which SBBC administration is closed, the formal written protest must be received on or before 5:00 p.m. ET of the next calendar day that is not a Saturday or Sunday, state holiday or days during which SBBC administration is closed. No submissions made after the Bid opening amending or supplementing the Bid shall be considered. Section 120.57(3)(b), Florida Statutes, as currently enacted or as amended from time to time, states that **“The formal written protest shall state with particularity the facts and law upon which the protest is based”**. Any person who files an action protesting an intended decision shall post with SBBC, **at the time of filing the formal written protest**, a bond, payable to SBBC, in an amount equal to one percent (1%) of SBBC's estimate of the total volume of the contract. SBBC shall provide the estimated contract amount to the vendor within 72 hours, excluding Saturdays, Sundays and other days during which SBBC administration is closed, of receipt of notice of intent to protest. The estimated contract amount is not subject to protest pursuant to Section 120.57(3), Florida Statutes. The bond shall be conditioned upon the payment of all costs which may be adjudged against the protestant in an Administrative Hearing in which the action is brought and in any subsequent appellate court proceeding. In lieu of a bond, SBBC may accept a cashier's check, official bank check or money order in the amount of the bond. If, after completion of the Administrative Hearing process and any appellate court proceedings, SBBC prevails, SBBC shall recover all costs and charges which shall be included in the Final Order or judgment, including charges made by the Division of Administrative Hearings, but excluding attorney's fees. Upon payment of such costs and charges by the protestant, the bond shall be returned. **All documentation necessary for the protest proceedings shall be provided electronically by SBBC.**
37. (Continued):
- Failure to file a notice of protest or to file a formal written protest within the time prescribed by Section 120.57(3), Florida Statutes, or a failure to post the bond or other security required by SBBC Policy 3320 within the time allowed for filing a bond, shall constitute a waiver of proceedings. The failure to post the bond required by SBBC Policy 3320, Part VIII, as currently enacted or as amended from time to time, shall constitute a waiver of proceedings. Notices of protests, formal written protests, and the bonds required by Policy 3320, shall be filed at the office of the Director, Procurement and Warehousing Services, 7720 West Oakland Park Boulevard, Suite 323, Sunrise, Florida 33351-6704 (fax 754-321-0936). Fax filing shall not be acceptable for the filing of bonds.**
38. **SUBMITTAL OF BIDS:** All Bidders are reminded that it is the sole responsibility of the BIDDER to assure that their bid is time stamped in PROCUREMENT AND WAREHOUSING SERVICES on or before 2:00 p.m. ET on date due. The address for bid submittal, including hand delivery and overnight courier delivery, is indicated as: 7720 West Oakland Park Boulevard, Suite 323, Sunrise, Florida 33351-6704. The Bidder is fully and completely responsible for the payment of all delivery costs associated with the delivery of their bid or related material. Procurement and Warehousing Services shall not accept delivery of any bid or related material requiring SBBC to pay for any portion of the delivery cost or the complete delivery cost. Prior to bid submittal, it is the responsibility of the Bidder to be certain that all Addenda released have been received, that all Addendum requirements have been completed, and that all submittals required by the Addendum have been timely filed. (See General Condition 1.)
39. **PACKING SLIPS:** It shall be the responsibility of the Awardee to attach all packing slips to the OUTSIDE of each shipment. Packing slip must reference SBBC Purchase Order number/control number. Failure to provide packing slip attached to the outside of shipment shall result in refusal of shipment at Awardee's expense.
40. **USE OF OTHER CONTRACTS:** SBBC reserves the right to utilize any other SBBC contract, any State of Florida Contract, any contract awarded by any other city or county governmental agencies, other school s, other community college/state university system cooperative bid agreement, or to directly negotiate/purchase per SBBC and/or Rule 6A-1.012, Florida Administration Code as currently enacted or as amended from time to time, in lieu of any offer received or award made as a result of this bid if it is in its best interest to do so.
41. **INDEMNIFICATION: This General Condition of the bid is NOT subject to negotiation and any bid that fails to accept these conditions shall be rejected as "non-responsive."**
- a) SBBC agrees to be fully responsible for its acts of negligence or its agents' acts of negligence when acting within the scope of their employment and agrees to be liable for any damages resulting from said negligence. Nothing herein is intended to serve as a waiver of sovereign immunity by SBBC. Nothing herein shall be construed as consent by SBBC to be sued by third parties in any matter arising out of any contract. Nothing herein shall be construed as a waiver by SBBC of any rights or limits to liability under Section 768.28, Florida Statutes.
- b) AWARDEE agrees to indemnify, hold harmless and defend SBBC, its agents, servants and employees from any and all claims, judgments, costs and expenses including, but not limited to, reasonable attorney's fees, reasonable investigative and discovery costs, court costs and all other sums which SBBC, its agents, servants and employees may pay or become obligated to pay on account of any, all and every claim or demand, or assertion of liability, or any claim or action founded thereon, arising or alleged to have arisen out of the products, goods or services furnished by the AWARDEE, its agents, servants or employees; the equipment of the AWARDEE, its agents, servants or employees while such equipment is on premises owned or controlled by SBBC; or the negligence of AWARDEE or the negligence of AWARDEE's agents when acting within the scope of their employment, whether such claims, judgments, costs and expenses be for damages, damage to property including SBBC's property, and injury or death of any person whether employed by the AWARDEE, SBBC or otherwise.
42. **PURCHASE BY OTHER PUBLIC AGENCIES:** With the consent and agreement of the awarded contractor(s), purchases may be made under this bid by other agencies. Such purchases shall be governed by the same terms and conditions as stated herein.
43. **GOVERNING LAW:** This ITB, and any award(s) resulting from this ITB shall be interpreted and construed in accordance with the laws of the State of Florida. Any protests arising from this ITB shall be subject to Section 120.57(3), Florida Statutes. Any disputes or controversies arising out of a contract award under this ITB shall be submitted to the jurisdiction of the state courts of the Seventeenth Judicial Circuit Court in and for Broward County, Florida.

44. **PUBLIC ENTITY CRIMES:** Section 287.133(2)(a), Florida Statutes, as currently enacted or as amended from time to time, states that a person or affiliate who has been placed on the convicted vendor list following a conviction for a public entity crime may not submit a bid on a contract to provide any goods or services to a public entity, may not submit a bid on a contract with a public entity for the construction or repair of a public building or public work, may not submit bids on leases of real property to a public entity, may not be awarded or perform work as a contractor, supplier, subcontractor, or consultant under a contract with any public entity, and may not transact business with any public entity in excess of the threshold amount provided in Section 287.017 for CATEGORY TWO [currently \$25,000] for a period of 36 months from the date of being placed on the convicted vendor list.
45. **CERTIFICATION REGARDING DEBARMENT, SUSPENSION, INELIGIBILITY OR VOLUNTARY EXCLUSION - Lower Tier Covered Transactions:** Executive Order 12549, as currently enacted or as amended from time to time, provides that, to the extent permitted by law, Executive departments and agencies shall participate in a government-wide system for non-procurement debarment and suspension. A person who is debarred or suspended shall be excluded from Federal financial and non-financial assistance and benefits under Federal programs and activities. Except as provided in § 85.200, Debarment or Suspension, § 85.201, Treatment of Title IV HEA participation, and § 85.215, Exception Provision, debarment or suspension of a participant in a program by one agency shall have government-wide effect. A lower tier covered transaction is, in part, any transaction between a participant [SBBC] and a person other than a procurement contract for goods or services, regardless of type, under a primary covered transaction; and any procurement contract for goods or services between a participant and a person, regardless of type, expected to equal or exceed the Federal procurement small purchase threshold fixed at 10 U.S.C. 2304(g) and 41 U.S.C. 253(g) (currently \$100,000) under a primary covered transaction; or any procurement contract for goods or services between a participant and a person under a covered transaction, regardless of amount, under which that person shall have a critical influence on or substantive control over that covered transaction. A participant may rely upon the certification of a prospective participant in a lower tier covered transaction that it and its principals are not debarred, suspended, proposed for debarment under 48 CFR part 9, subpart 9.4, ineligible, or voluntarily excluded from the covered transaction, unless it knows that the certification is erroneous. Each participant shall require participants in lower tier covered transactions to include the certification for it and its principals in any bid submitted in connection with such lower tier covered transactions.
- CERTIFICATION**
- a) The prospective lower tier participant certifies, by submission of this bid, that neither it nor its principals is presently debarred, suspended, proposed for debarment, declared ineligible, or voluntarily excluded from participation in this transaction by any Federal department or agency.
- b) Where the prospective lower tier participant is unable to certify to any of the statements in this certification, such prospective participant shall attach an explanation to this bid.
- Every time a Bid is submitted that includes reference to this Form, a new Form is required. Any Bid that does not include this required Form shall not be evaluated and shall not be considered for award. **A signature is required on BOTH the Debarment Form AND the Invitation to Bid page.** A signature on one document cannot be substituted for the signature required on the other document. **Failure to complete and sign both documents requiring signature shall result in rejection of bid submitted.**
46. **REASONABLE ACCOMMODATION:** Individuals with disabilities requesting accommodations under the Americans with Disabilities Act (ADA) may call Equal Educational Opportunities (EEO) at 754-321-2150 or Teletype Machine TTY 754- 321-2158.
47. **SEVERABILITY:** In case of any one or more of the provisions contained in this Bid shall be for any reason be held to be invalid, illegal, unlawful, unenforceable or void in any respect, the invalidity, illegality, unenforceability or unlawful or void nature of that provision shall not affect any other provision and this Bid shall be considered as if such invalid, unlawful, unenforceable or void provision had never been included herein.
48. **DISTRIBUTION:** DemandStar by Onvia, www.demandstar.com, is the official method approved by Procurement and Warehousing Services for the distribution of all competitive solicitations including ITBs and RFPs. It is the responsibility of all Bidders to assure they have received all necessary documents, including Addenda and have included all necessary information within their response. SBBC is not responsible for Bidder's failure to obtain complete bidding documents from DemandStar. SBBC reserves the right to reject any bid as non-responsive for failure to include all necessary documents or required Addenda. For information regarding the above referenced solicitation, contact the designated Purchasing Agent as stated herein.
49. **LOBBYIST ACTIVITIES:** In accordance with SBBC Policy 1100B, as currently enacted or as amended from time to time, persons acting as lobbyists must state, at the beginning of their presentation, letter, telephone call, e-mail or facsimile transmission to School Board Members, Superintendent or Members of Senior Management, the group, association, organization or business interest she/he is representing.
- a) A lobbyist is defined as a person who for immediate or subsequent compensation, (e.g., monetary profit/personal gain) represents a public or private group, association, organization or business interest and engages in efforts to influence School Board Members on matters within their official jurisdiction.
- b) A lobbyist is not considered a person representing school-affiliated groups (e.g., PTA, DAC, Band Booster Associations, etc.) nor a public official acting in her/his official capacity.
- c) Lobbyists shall annually (July 1) disclose in each instance and for each client prior to any lobbying activities, their identity and activities by completing the lobbyist statement form which can be obtained from Official School Board Records, School Board Member's Offices or the Superintendent's Office and shall be recorded on SBBC's website, www.browardschools.com.
- d) The lobbyist must disclose any direct business association with any current elected or appointed official or employee of SBBC or any immediate family member of such elected or appointed official or employee of SBBC.
- e) Senior-level employees (Pay Grade 30 and above) and/or School Board Members are prohibited from lobbying activities for one year after resignation or retirement or expiration of their term of office.
50. **TIE BID PROCEDURES:** When identical prices are received from two or more Bidders and all other factors are equal, priority for award shall be given to Bidders in the following sequence:
- A business that certifies that it has implemented a drug-free workplace program shall be given preference in accordance with the provisions of Chapter 287.087, Florida Statutes, as currently enacted or as amended from time to time;
 - The Broward County Certified Minority/Women Business Enterprise Bidder;
 - The Palm Beach County or Miami-Dade County Certified Minority/Women Business Enterprise Bidder;
 - The Florida Certified Minority/Women Business Enterprise Bidder;
 - The Broward County Bidder, other than a Minority/Women Business Enterprise Bidder;
 - The Palm Beach County or Miami-Dade County Bidder, other than a Minority/Women Business Enterprise vendor;
 - The Florida Bidder, whose main office is in the State of Florida, other than a Minority/Women Business Enterprise vendor.
 - If application of the above criteria does not indicate a priority for award, the award shall be decided by a coin toss. The coin toss shall be held publicly in Procurement and Warehousing Services; the tie low bid Bidders invited to be present as witnesses.
- Included as a part of these bid documents is a Form entitled **SWORN STATEMENT PURSUANT TO CHAPTER 287.087, FLORIDA STATUTES, AS CURRENTLY ENACTED OR AS AMENDED FROM TIME TO TIME, ON PREFERENCE TO BUSINESSES WITH DRUG-FREE WORKPLACE PROGRAMS.** This form shall be used by the Bidder to certify that it has implemented a drug-free workplace program. In order for bid to be considered, the Invitation to Bid form (Page 1 of this bid) must be properly signed in order for the bid to be considered. A Bidder cannot sign this form in lieu of properly signing the Invitation to Bid form.
51. **DISPUTES:** in the event of a conflict between the documents, the order of priority of the documents shall be as follows:
- Addenda released for this ITB, with the latest Addendum taking precedence, then;
 - The ITB; then
 - Bidder's submitted bid.
- In case of any other doubt or difference of opinion, the decision of SBBC shall be final and binding on both parties.

52. **MINORITY/WOMEN BUSINESS ENTERPRISE (M/WBE) PARTICIPATION:** SBBC has implemented a Minority/Women Business Enterprise (M/WBE) Program as part of the SBBC's competitive solicitation and contracting activity in accordance with School Board Policy 7007-A Administrative Procedures for The School Board of Broward County, Florida's Supplier Diversity & Outreach Program. The purpose of the program is to utilize available minority and women businesses within the Board's market area to compete for the award of SBBC construction and purchasing contracts. M/WBE vendors utilized for this contract must be certified by SBBC's Supplier Diversity & Outreach Program Office prior to submission of Bid. For information on M/WBE Certification, contact SBBC's Supplier Diversity & Outreach Program at 754-321-0550 or visit www.browardschools.com/sdop.
53. **SBBC MATERIAL NUMBER:** The seven-digit number shown in parenthesis at the beginning of an item on the Bid Summary Sheet represents SBBC's material number for the item. It does not represent any manufacturer/distributor model/part number.
54. **SBBC PHOTO IDENTIFICATION BADGE:**
- Background Screening:** Awardee agrees to comply with all the requirements of Sections 1012.32 and 1012.465, Florida Statutes, and that Awardee and all its personnel who (1) are to be permitted access to school grounds when students are present, (2) will have direct contact with students, or (3) have access or control of school funds shall successfully complete the background screening required by the referenced statutes and meet the standards established by the statutes. **Personnel shall include employees, representatives, agents or sub-contractors performing duties under the contract to SBBC, and who meet any or all of the three requirements identified above.** This background screening shall be conducted by SBBC in advance of Awardee or its personnel providing any services. Awardee shall bear the cost of acquiring the background screening required under Section 1012.32, Florida Statutes, and any fee imposed by the Florida Department of Law Enforcement to maintain the fingerprints provided with respect to Awardee and its personnel. The Parties agree that the failure of Awardee to perform any of the duties described in this section shall constitute a material breach of this ITB entitling SBBC to terminate immediately with no further responsibilities or duties to perform under this Agreement. Awardee agrees to indemnify and hold harmless SBBC, its officers and employees of any liability in the form of physical or mental injury, death or property damage resulting in Awardee's failure to comply with the requirements of this section or Sections 1012.32 and 1012.465, Florida Statutes.
- SBBC issued identification badges must be worn at all times when on SBBC property and must be worn where they are visible and easily readable.**
- As of July 1, 2015, Fieldprint, Inc. has been contracted to provide all background and fingerprinting services. All questions pertaining to fingerprinting, photo identification and background check services must be directed to the Project Coordinator at 754-321-1830 or 754-321-2374. **Each individual, for whom a SBBC photo identification badge is requested, must be registered into the Fieldprint, Inc. applicant enrollment website.** A background check shall be conducted for each badge applicant. SBBC reserves the right to require additional information, should it be necessary, and to deny the issuance of a badge to an applicant. Any applicant, that has been denied a badge, is prohibited from entering SBBC property as an employee, sub-contractor or agent of a contract Awardee. **Applicant enrollment and scheduling website is www.fieldprintflorida.com.** The total fee(s) for the SBBC photo identification badge, fingerprinting and a FBI background check can be found at the following website: http://www.broward.k12.fl.us/police/pdf/secle/FIELDPRINT_CODES.pdf. Payment options can be made by electronic check (e-check), Visa, MasterCard or use of an established escrow account code. **These fees are non-refundable and are subject to change without notice. Badges are issued for a one-year period and must be renewed annually. The renewal date shall be one year from date of issuance. Failure to renew the badge, at that time, shall result in the Awardee being required to re-apply and pay the going rate for badging and fingerprinting.**
- Awardees shall return expired and/or terminated employee badges to the following location: The School Board of Broward County, Florida, Attn: Fieldprint, Inc., 600 S.E. 3rd Avenue, Fort Lauderdale, Florida 33301.**
55. **AUDIT AND INSPECTION OF AWARDEE'S DOCUMENTS AND RECORDS:** The District or its representative reserves the right to inspect and/or audit all the Awardee's documents and records as they pertain to the products and services delivered under this agreement. Such rights shall be exercised with notice to the Awardee to determine compliance with and performance of the terms, conditions and specifications on all matters, rights and duties, and obligations established by this agreement. Documents/records in any form shall be open to the District or State's representative and may include but are not limited to all correspondence, ordering, payment, inspection, and receiving records, contracts or sub-contracts that directly or indirectly pertain to the transactions between the District and the Awardee(s).
56. **ORIGINAL DOCUMENT FORMAT:** Only the terms and conditions of this solicitation as they were released by SBBC, or amended via Addendum, are valid. Any modification to any term or condition by a Bidder is not binding unless it is expressly agreed to, in writing, by SBBC.
57. **CREDIT CARDS:** Individual schools and departments may place some orders and utilize, as the form of payment, a District-issued credit card to the extent authorized by SBBC. These orders shall be made via phone or fax for direct delivery and billing to the requesting work location. Please note that credit card purchases will benefit all vendors by providing immediate payment (i.e. within 48-72 hours), thereby eliminating the need to submit an invoice to the District's Accounts Payable Department or reconcile receivable balances. For credit card purchases, all Awardees must have the capability to accept fax orders, which must be confirmed by calling back the requesting work location to verify prices and obtain a credit card number. Only actual items shipped/delivered can be charged to the credit card account (i.e., no back-orders). All purchase deliveries must include a packing slip or receipt/invoice listing the items and prices of goods delivered. For security reasons, the credit card charge receipt showing the work location's credit card number cannot be attached to the packing slip or receipt/invoice submitted as part of the purchase delivery. District work locations may request that an Awardee maintains secure records of the credit card account assigned an alias or password, to avoid divulging the actual credit card number upon every purchase.
58. **NONCONFORMANCE TO CONTRACT CONDITIONS:** Items offered may be tested for compliance with bid conditions and specifications at any time. Items delivered, not conforming to bid conditions or specifications, may be rejected and returned at Awardee's expense. Goods or services not delivered as per delivery date in bid and/or Purchase Order may be rejected upon delivery and/or may be purchased on the open market. Any increase in cost may be charged against the Awardee. Any violation of these stipulations may also result in:
- For a period of two years, any bid submitted by Awardee shall not be considered and shall not be recommended for award.
 - All departments being advised not to do business with Awardee.
59. **CONE OF SILENCE:** Any Bidder, or lobbyist for a Bidder, is prohibited from having any communications (except as provided in this rule) concerning any solicitation for a competitive procurement with any School Board member, the Superintendent, any Evaluation Committee Member, or any other School District employee after Procurement and Warehousing Services releases a solicitation to the General Public. All communications regarding this solicitation shall be directed to the designated Purchasing Agent unless so notified by Procurement and Warehousing Services. This "Cone of Silence" period shall go into effect and shall remain in effect from the time of release of the solicitation until the contract is awarded by SBBC. Further, any Awardee, its principals, or their lobbyists shall not offer campaign contributions to School Board Members or offer contributions to School Board Members for campaigns of other candidates for political office during the period in which the Awardee is attempting to sell goods or services to SBBC. This period of limitation of offering campaign contributions shall commence at the time of the "cone of silence" period for any solicitation for a competitive procurement as described by School Board Policy 3320, Part II, Section GG as well as School Board Policy 1007, Section 5.4 – Campaign Contribution Fundraising. **Any Bidder or lobbyist who violates this provision shall cause their Bid (or that of their principal) to be considered non-responsive and therefore be ineligible for award.**
60. **TERMINATION:** This contract award may be terminated with or without cause by SBBC during the term hereof thirty (30) days after the Superintendent gives written notice to the other parties that a recommendation shall be made to SBBC for the contract award's termination.
61. **EVALUATION AND BIDS:** SBBC evaluates all Bids in accordance with Chapters 119.071 and 286.0113, Florida Statutes.

62. **MEET OR RELEASE:** If during the contract term, SBBC is offered a lower price from a third party supplier for a product or service awarded under this contract, or offers another item that meets or exceeds the specifications for the item at a lower price than the awarded price, SBBC shall request Awardee to meet the lower price offered by the third party supplier. Awardee shall be required to respond to this request within three (3) days of request. If Awardee is unable to meet the lower price, SBBC shall be released from its contractual obligation to purchase the item under this contract. No response to this request shall indicate that Awardee is unable to offer item at a lower price. This action, purchasing awarded item from third party supplier, shall not hold SBBC in default of contract. Each purchase shall be considered separate and apart from each other.

63. **CONFIDENTIAL RECORDS:** Notwithstanding any provision to the contrary within this Contract, any party contracting with SBBC under this Contract shall fully comply with the requirements of Sections 1002.22 and 1002.221, Florida Statutes; Family Educational Rights and Privacy Act (FERPA), and any other state or federal law or regulation regarding the confidentiality of student information and records. Each such party agrees, for itself, its officers, employees, agents, representatives, contractors or subcontractors, to fully indemnify and hold harmless SBBC and its officers and employees for any violation of this section, including, without limitation, defending SBBC and its officers and employees against any complaint, administrative or judicial proceeding, payment of any penalty imposed upon SBBC, or payment of any and all costs, damages, judgments or losses incurred by or imposed upon SBBC arising out of a breach of this covenant by the party, or an officer, employee, agent, representative, contractor, or sub-contractor of the party to the extent that the party or an officer, employee, agent, representative, contractor, or sub-contractor of the party shall either intentionally or negligently violate the provisions of this section or of Sections 1002.22 and/or 1002.221, Florida Statutes.

Awardee agrees that it may create, receive from or on behalf of SBBC, or have access to, records or record systems that are subject to FERPA and/or HIPAA (collectively, the "Confidential Records"). Awardee represents, warrants, and agrees that it shall: (1) hold the Confidential Records in strict confidence and shall not use or disclose the Confidential Records except as (a) permitted or required by this Agreement, (b) required by law, or (c) otherwise authorized by the SBBC in writing; (2) safeguard the Confidential Records according to commercially reasonable administrative, physical and technical standards as required by law; and (3) continually monitor its operations and take any and all action necessary to assure that the Confidential Records are safeguarded in accordance with the terms of this Agreement. At the request of the SBBC, Awardee agrees to provide SBBC with a written summary of the procedures Awardee uses to safeguard the Confidential Records. A breach of these confidentiality requirements shall constitute grounds for the SBBC to terminate any Agreement with Awardee.

64. **PROPRIETARY INFORMATION:** Pursuant to Chapter 119, Florida Statutes, bids received as a result of this ITB shall not become public record until thirty (30) days after the date of opening or until posting of the recommendation for award, whichever occurs first. Thereafter, all bid documents or other materials submitted by all Bidders in response to this ITB shall be open for inspection by any person and in accordance with Chapter 119, Florida Statutes. To the extent a Bidder asserts any portion of its bid is confidential and exempt, long with specific citations of the Florida Statutes establishing the confidentiality or exemption. Failure to identify the portions of the bid claimed to be exempt or the specific statutory authority establishing the exemption shall be deemed a waiver by the Bidder that any unidentified portion of the bid is confidential or exempt from disclosure under Chapter 119, Florida Statutes.

Should a public records request for bid documents or other materials submitted by a Bidder be submitted, SBBC shall notify the contact person identified in the bid of the request in writing. The notice provided shall indicate that requested materials shall be produced unless, within ten (10) calendar days of the date of the written notification, the Awardee initiated an action in a court of competent jurisdiction to obtain an injunction or protective order prohibiting the release of the requested materials. Awardee shall name the party requesting the materials as a defendant and shall not name SBBC as a party to the action. Awardee agrees to hold SBBC harmless from any award to a plaintiff for damages, costs or attorney's fees based on nondisclosure of information asserted to be confidential and exempt. Failure to timely initiate the action shall be deemed a waiver by the Awardee that the requested information is confidential and exempt. Awardee agrees to waive any cause of action it may have against SBBC for the release of materials pursuant to a public records request except those based on the intentional or grossly negligent conduct of any employee of SBBC. Submission by a Bidder in response to this ITB shall be deemed as Bidder's consent to the foregoing conditions.

SECTION 4, SPECIAL CONDITIONS

1. **INTRODUCTION AND SCOPE:** The School Board of Broward County, Florida (hereinafter referred to as "SBBC") desires bids on **CAFETERIA EQUIPMENT** as specified herein. The scope of requirements includes, but is not limited to, **CAFETERIA EQUIPMENT**. The Awardee(s) shall receive individual Purchase Orders specifying the name and ship to address of the various schools, departments and centers.
2. **BID SUBMITTAL:** One (1) printed copy of the complete bid MUST be sent with the bid in time for bid opening. Additionally, one identical electronic version of the bid, in PDF Format on a flash drive with exception to the Electronic Bid Summary Sheet (Excel [.xls]), which must be both in the original PDF file as well as separate attachments, should be submitted in time for bid opening to:

Larissa Seda, Procurement & Warehousing Services Department
7720 West Oakland Park Blvd – Suite 323
Sunrise, FL 33351.

All materials submitted with bids need to be clearly marked with the Bid number and Title.

3. **TERM:** The award of this bid shall establish a contract for the period **beginning from January 1st, 2018 and continuing through December 31, 2019**. Bids shall not be considered for a shorter period of time. Items shall be ordered on an as-needed basis. If only one bid is received, the term of the contract shall be reduced to one year.
4. **AWARD:** In order to meet the needs of SBBC, each **ITEM OR GROUP**, as indicated on the Bid Specifications Form and Bid Summary Sheet shall be awarded to one (1) primary and one (1) alternate responsive and responsible Bidders meeting specifications, terms and conditions. The lowest Awardee for an item or group shall be considered the primary vendor and should receive the largest volume of work. SBBC reserves the right to procure goods from the second lowest Bidder if: a) the lowest Bidder cannot comply with delivery requirements or specifications; b) the lowest Bidder is not in compliance with delivery requirements or specifications on current or previous orders; c) in cases of emergency; or d) if it is in the best interest of SBBC. When a bid has both a primary and alternate Awardee, and the primary Awardee is unable to perform during the term of the contract, Procurement and Warehousing Services shall negotiate with the alternate Awardee for the same or lower unit prices as those submitted by the primary Awardee.

Unit prices must be stated in the space provided on the electronic Bid Summary Sheet. Bids for **individual items (not in groups)** must meet specifications in order to be considered for award. For **items in groups**, it is necessary to bid on every item in the group, and all items in the group must meet specifications in order to be considered for award. In the event that any item in the group does not meet the specifications, the entire group shall be disqualified. SBBC may need to order an individual component within a group. All items within a group must have an individual cost. Failure to state the individual cost for any item within a group shall result in disqualification of the group. Bidder should carefully consider each item for conformance to specifications.

SBBC reserves the right to release new bids for any item(s) that are included in catalogs/price lists submitted, is a packaged order, has special installation requirements or is in the best interest of SBBC.

After award of this bid, any Awardee who violates any specification, term or condition of this bid can be found in default of its contract, have its contract canceled, be subject to the payment of liquidated damages, and be removed from the bid list and not be eligible to do business with SBBC for two years, as described in General Conditions 21 and 58.

SECTION 4 – SPECIAL CONDITIONS (Continued)

5. **INFORMATION:** Any questions by prospective Bidders concerning this Invitation to Bid should be addressed to **Larissa Seda, Procurement and Warehousing Services, 754-321-0524 or e-mail at Larissa.Seda@browardschools.com** who is authorized only to direct the attention of prospective Bidders to various portions of the bid so they may read and interpret such for themselves. Neither **Ms. Seda**, nor any employee of SBBC, is authorized to interpret any portion of the bid or give information as to the requirements of the bid in addition to that contained in the written bid document. **Questions should be submitted in accordance with General Condition 5 no later than end of business day on July 19, 2017.** Interpretations of the bid or additional information as to its requirements, where necessary, shall be communicated to Bidders only by written Addendum. Any verbal or written information, which is obtained other than by information in this ITB document or by Addenda, shall not be binding on SBBC.
6. **BIDDING PREFERENCE LAWS: ALL BIDDERS MUST COMPLETE AND SUBMIT SECTION 7, ATTACHMENT 4 (LEGAL OPINION OF BIDDER'S PREFERENCE) TO BE CONSIDERED FOR AWARD. THIS FORM SHOULD ALSO BE ACCOMPANIED BY A PRINTOUT OF THE BIDDER'S CORPORATION RECORD AS REGISTERED WITH THE DIVISION OF CORPORATIONS, FLORIDA DEPARTMENT OF STATE AND CAN BE ACCESSED AT WWW.SUNBIZ.ORG .**

The State of Florida provides a Bidder's preference for Bidders whose principal place of business is within the State of Florida for the purchase of personal property. **The local preference is five (5) percent.** Bidders whose **principal place of business** is outside the State of Florida must have an Attorney, licensed to practice law in the out-of-state jurisdiction, as required by Florida Statute 287.084(2), execute the "Opinion of Out-of-State Bidder's Attorney on Bidding Preferences" form, **Section 7, Attachment 4**, and must submit this form with submitted bid. Such opinion should permit SBBC's reliance on such attorney's opinion for purposes of complying with Florida Statute 287.084. Florida Bidders are not required to have an Attorney render an opinion but the Florida Bidder must complete its portion of this form. Failure to submit and execute this form, with bid, shall result in bid being considered "non-responsive" and bid rejected.

7. **U. S. DEPARTMENT OF AGRICULTURE CERTIFICATION (DEBARMENT AND SUSPENSION):** A copy of Form AD-1048 (1/92) is included as a part of these bid documents in **EXHIBIT B**. Section 3017.510 of 7 CFR Part 3017 requires the submission of the completed Form: Certification Regarding Debarment, Suspension, Ineligibility and Voluntary Exclusion - Lower Tier Covered Transactions; for all USDA Food and Nutrition Service programs. No vendor shall be allowed to participate in any procurement activity if any federal department or agency has debarred, suspended, or otherwise excluded that vendor from participation in a procurement activity. This form should be **completed, signed and submitted with the bid or upon request** in order for the submitted bid to be considered. Every time a bid is submitted that includes reference to this Form, a new Form is required. Any bid that does not include this required Form shall not be evaluated and shall not be considered for award. **A signature is required on BOTH the Form AND the Invitation to Bid page.** A signature on one document cannot be substituted for the signature required on the other document. **Failure to complete and sign both documents requiring signature shall result in rejection of bid submitted.**
8. **DESCRIPTIVE LITERATURE:** If bidding other than the make(s) and model(s) specified in this bid, it is required that **COMPLETE DESCRIPTIVE TECHNICAL LITERATURE ON THE ITEM BEING BID, BE SUBMITTED WITH THE BID OR UPON REQUEST.** Such literature shall be in sufficient detail to indicate conformance with the specifications of the make(s) and model(s) specified in the bid. **FAILURE TO PROVIDE THIS DESCRIPTIVE LITERATURE IN SUFFICIENT DETAIL TO COMPLETE THE EVALUATION OF THE MAKE(S) AND MODEL(S) OFFERED IN THIS BID, WITH THIS BID OR UPON REQUEST, SHALL RESULT IN DISQUALIFICATION OF BID SUBMITTED.**

BID ITEM 31: If bidding other than the brand and model specified in this Bid, it is required that **COMPLETE DESCRIPTIVE TECHNICAL LITERATURE WHICH CONTAINS A COMPLETE DESCRIPTION OF THE STRUCTURES, EQUIPMENT AND PARTS AS WELL AS A SHOP DRAWING AND/OR SCALE MODEL BE SUBMITTED WITH THIS BID OR UPON REQUEST. FAILURE OF THE BIDDER TO PROVIDE THIS INFORMATION WITH THE BID OR UPON REQUEST IN SUFFICIENT DETAIL TO INDICATE CONFORMANCE WITH BID SPECIFICATIONS OF THE BRAND(S) AND MODEL(S) SPECIFIED IN THE BID WILL RESULT IN DISQUALIFICATION OF BID ITEM.**

SECTION 4 – SPECIAL CONDITIONS (Continued)

9. **MODEL NUMBER CORRECTIONS:** If the **model number** for the make specified on the Bid Summary Sheet is: **a) no longer available** and has been replaced with a new updated model with new specifications, the Bidder should **submit complete descriptive literature** on the new model number; or **b) incorrect, the corrected model number should be noted** on the Bid Summary Sheet, in the space provided.
10. **QUANTITIES:** The quantities listed on the electronic Bid Summary Sheet are estimated quantities to be ordered throughout the contract period for each item and are not a guarantee. Actual quantities ordered throughout the contract period may be greater or less than the bid estimates and shall be furnished at the fixed contract price. Purchases will be requested as needed throughout the contract period and as few as one each may be ordered at one time.
11. **NEW EQUIPMENT:** Product offered shall be for **new** equipment; i.e., units that have not been previously used in any way and are being actively marketed by the manufacturer. Therefore, **reconditioned, refurbished, rebuilt, discontinued, used, shop worn, demonstrator, prototype equipment or other type of appliances of this kind are not acceptable and will be rejected.** Minor parts within the appliance, however, may have remanufactured components.
12. **MINIMUM ORDER:** Price or quantity restrictions stated by any Bidder shall not be considered for award. Any bid which stipulates minimum order by quantity or dollar amount shall not be considered for award. Each item must be bid separately and no attempt is to be made to tie any item or items in with any other item or items.
13. **DELIVERY:** Bidder shall indicate delivery information on Bid Summary Sheets where indicated. Delivery is desired no later than **45 days after receipt of order (ARO)**. Offers, which exceed this period, may be rejected if it is in the best interest of SBBC.
14. **ACCEPTANCE OF MATERIALS:** The material delivered under this bid shall remain the property of the Awardee until a physical inspection and actual usage of this material is made and thereafter accepted to the satisfaction of SBBC and must comply with the terms herein, and be fully in accordance with specifications. In the event the material supplied to SBBC is found to be defective or does not conform to specifications, SBBC reserves the right to cancel the order upon written request to the Awardee and return the product to Awardee, at Awardee's expense. Awardee shall be responsible for pick-up of defective/rejected materials. After 30 days notification to the Awardee, if the materials are not removed, they become the property of SBBC. Awardee shall be responsible for any disposition charges.
15. **INSTALLATION:** All equipment shall be installed according to the standards established by the terms, specifications, drawings and construction notes and meet manufacturer's specifications and industry standards. All work performed by the Awardee and/or subcontractors pursuant to this contract shall meet industry accepted standards, and shall be performed in a professional and workmanlike manner by staff with the necessary skills, experience and knowledge. Installers must follow the following guidelines:
- A. Employee(s) of the installer shall report to the school's main office, register in the appropriate sign-in book, list the number of employees on the school site and sign out at the end of the day.
 - B. All of the installer's employees shall wear SBBC identification badges which contain a photo, individual's name and the company name. Other types of identification badges are not acceptable. Failure to properly wear and display identification will result in dismissal of installer's employee from School Board property.
 - C. All of the installer's employees shall be clean and appropriately dressed at all times while on school campus. Shirts shall be worn at all times.

SECTION 4 – SPECIAL CONDITIONS (Continued)

15. INSTALLATION (Continued):

- D. Awardee/Installer shall furnish, at their own expense, all supervision, equipment, machines, tools, materials, labor, transportation and all necessary items needed to perform site preparation and installation of equipment.
- E. Awardee shall protect all personnel (school staff and installer's employees), and students or others on school campuses against hazards and/or injuries that might result installer's work since generally the site preparation and installation of equipment will occur while school is in session. This shall include, but not be limited to the erection of barricades and signs to isolate the worksite and minimize the risk of injury to anyone on the school campus or site location.
- F. Unpack, uncrate and install equipment at the site location in accordance with manufacturer's equipment specifications, bid specifications and SBBC policies and procedures. Installation shall include equipment set up, leveling, and installation of accessories, shelves, factory start-up and training. Final electrical, plumbing and gas hook-ups shall be done by SBBC personnel.
- G. All rubbish, refuse, scrap materials and debris (including pallets) as a result of Awardee's installation must be cleared from the site location on a daily basis by the Awardee/installer. **No rubbish, refuse or scrap materials as a result of installation shall be placed in SBBC dumpsters.** Leave the work site clean and free of any debris at the end of each work day. Any materials left by vendors and reported by school staff must be removed within 24 hours.
- H. At completion of installation, the site shall be in a ready-to-use condition, free of debris. Restore site to its original condition.

- 16. PLACEMENT, SET-UP AND INSTALLATION:** Awardee(s) shall be responsible for inside delivery, setting in place, connecting separate items, removing cartons, installing refrigerator and warmer shelves, plug-in and remove tape when necessary. All tables, shelves, racks, etc. must be delivered completely assembled. Level equipment where necessary is required. When necessary, sealing and caulking to the floor must be completed upon delivery. No electrical or plumbing hook-ups are required with the exception of ice machines. Ice machine price is to include disconnecting the existing ice machine and slide out of way and hook up of new machine to existing utilities. Do not remove any school board owned equipment from the premises.

The Food and Nutrition Services Department must be notified 72 hours in advance of delivery so that School Board electricians and plumbers can be notified and so that existing equipment can be disconnected and removed prior to vendor's arrival.

PLACEMENT, SET-UP AND INSTALLATION (FOR BID ITEMS 31): Awardee(s) shall be responsible for inside delivery, setting in place and connecting separate items. No electrical or plumbing hook-up is required. The installation should include, but not be limited to, removing tape, installing sneeze guards, tray rails, display cases, and other parts shipped separately, and removing and disposing all shipping materials. Awardee(s) must attach and level all separate pieces and leave serving line equipment ready for use. Awardee(s) is/are not responsible for final electrical and plumbing connections. Installation shall be completed on the same day of delivery. Factory start-up is required on all kettles, ovens, steamers, and combi-steamers.

- 17. PROTECTION OF PROPERTY:** The Awardee shall at all times guard against damage and/or loss to the property of SBBC, and shall replace and/or repair any loss or damages unless such is caused by the SBBC. SBBC may withhold payment or make such deductions, as it might deem necessary to insure reimbursement for loss and/or damages to the property through negligence of the Awardee.

SECTION 4 – SPECIAL CONDITIONS (Continued)

18. **INSTRUCTION MANUALS:** Awardee is required to furnish an instruction manual for each item bid. Each manual shall contain definition of equipment capabilities, technical description of equipment operation, description of malfunction identification and troubleshooting procedures.
19. **INVOICES:** Delivery copies, packing slips and invoices to SBBC **MUST** include the following to permit SBBC to verify prices with this contract and expedite the use of material.
- i. Material release number OR the control number
 - ii. Purchase Order number
 - iii. Complete description of the items
 - iv. Itemized list price
 - v. Total dollar amount shall be net

FAILURE OF AN AWARDEE TO PROVIDE THIS INFORMATION SHALL RESULT IN EITHER THE INVOICE BEING RETURNED FOR CLARIFICATION OR A DELAY IN PROCESSING SAID INVOICE FOR PAYMENT.

Invoices are to be mailed to The School Board of Broward County, Florida, Accounting and Financial Reporting Department, Attn: Accounts Payable, 600 S.E. 3rd Avenue, 7th Floor, Fort Lauderdale, Florida 33301.

20. **WARRANTY:** Manufacturer's standard warranty must be provided on all bid items. Warranty shall begin after delivery and acceptance by the user of the product. Warranty shall be stated in the spaces provided in the Bid Specifications Sheets.
21. **MODEL UPDATES:** If, **during the contract period**, the awarded **model is discontinued** by the manufacturer, the Awardee must advise SBBC Procurement and Warehousing Services, in writing, of the non-availability of the contract item and submit complete descriptive literature for the new updated model for SBBC evaluation and approval which must meet or exceed the specifications for the original contract item. The new model must be the same make as the awarded contract item or a brand and model that is listed as an approved brand for that bid item and must be offered at the contract price or less. Samples of the replacement item(s), if requested, must be supplied for evaluation by the appropriate SBBC staff. SBBC shall not be held liable for any damages incurred to the product during evaluation.
22. **PRICE ADJUSTMENTS:** Unit prices offered on this bid shall remain firm for the first **twelve (12) months** of this contract. Any request for price adjustment, with proper documented justification (letter from manufacturer indicating a price increase for the entire industry, not only for SBBC), shall be submitted, in writing, to the Procurement and Warehousing Services Department two weeks prior to the effective date of the requested adjustment and take effect only when the Awardee has received written approval from SBBC. Any price adjustment invoiced without prior written approval from SBBC shall not be paid and the invoice returned to the Awardee for correction.

Requests for price adjustments shall not exceed 3%. Price adjustment requests shall be evaluated on an annual basis thereafter.

Contract renewal periods for price increases will be subject to the same process. Price adjustments shall be negotiated in good faith with the Awardees and SBBC reserves the right to reject any price adjustments and cancel the renewal of any contract with an increase in prices.

23. **COMPANY REPRESENTATIVE:** Bidder is requested to indicate, in the space provided on the electronic Bid Summary Worksheet, the name, address, telephone number, etc., of the representative(s) who could make periodic scheduled visits to the schools, departments and centers and who will be available, **upon request, to resolve billing and delivery problems.**

SECTION 4 – SPECIAL CONDITIONS (Continued)

24. **CONTRACT RENEWAL:** The purpose of this bid is to establish a contract, at firm unit prices, for the purchase of estimated requirements for the items listed and may, by mutual agreement between SBBC and the Awardee, be renewed for three additional one-year periods and, if needed, 90 days beyond the expiration date of the final renewal period. Procurement and Warehousing Services, will, if considering renewing, request a letter of intent to renew from each Awardee, prior to the end of the current contract period. The Awardee will be notified when the recommendation has been acted upon by the School Board. All prices shall be firm through the period stated in Special Condition 21 - Price Adjustments for the term of the contract. The Bidder(s) agrees to this condition by signing its bid
25. **FORCE MAJEURE:** Except for the provisions of this bid, each party shall be excused from performance under this bid only for such period of time as the failure to perform is caused by or attributable to any event or circumstance beyond the direct control of such party. It is further provided that if either party shall fail to make any delivery or perform any service required by this bid as a result of any such event or circumstances beyond its own direct control, it shall have the right to make such delivery or perform such service within a reasonable time after the cause of such delay has been removed, and the other party shall accept such deferred delivery or performance.
26. **W-9 FORMS:** All Bidders are required to complete a W-9 form; it can be found at <https://www.irs.gov/pub/irs-pdf/fw9.pdf> , and submit with their bid.
27. **M/WBE UTILIZATION:** SBBC has implemented a Minority/Women Business Enterprise (M/WBE) Program as part of the SBBC's competitive solicitation and contracting activity in accordance with School Board Policy 7007-A Administrative Procedures for The School Board of Broward County, Florida's Supplier Diversity & Outreach Program. The purpose of the program is to utilize available minority and women businesses within the Board's market area to compete for the award of SBBC purchasing contracts. An M/WBE is defined by SBBC as any legal entity, other than a joint venture, which is organized to engage in commercial transactions and which is at least 51% owned, operated and controlled by minorities or women. For information on M/WBE Certification, contact SBBC's Supplier Diversity & Outreach Program at 754-321-0550 or visit www.browardschools.com/sdop. SBBC's Supplier Diversity & Outreach Program works to increase the participation of minority and women business enterprises in construction and purchasing contracts. It is the intent of the Supplier Diversity & Outreach Program to have a diverse group, as well as an equitable distribution of M/WBEs participating on any award of this Bid.
28. **M/WBE UTILIZATION REPORTING:** In an effort to monitor the achievement of the M/WBE goal the Awardee(s) agrees to submit, a completed Monthly M/WBE Utilization Report form, attached hereto as Exhibit "A2" and made a part of this contract. The timing of these reports must coincide with invoice submission. In addition to the M/WBE Utilization Report form, Awardee(s) shall also provide proof of payment made to each M/WBE Subcontractor which shall take the form of cancelled checks or check register photocopies, or any other valid form of documentation that serves to substantiate all payment amounts included in the Subcontractor Utilization Report. The Awardee(s) understands that each M/WBE utilized for the contract must be certified by SBBC, Supplier Diversity & Outreach Program Office.

SECTION 4 – SPECIAL CONDITIONS (Continued)

29. PARTNERS IN ENGAGEMENT: In order to receive MWBE participation pricing incentive, at the time the bid is submitted, the bidder shall identify the MWBE firms that will be utilized, the type of work to be performed and the percentage of participation. Any participation by firms not certified by the School Board of Broward County (SBBC) at the time of BID submission will not count in the evaluation process for the award of pricing incentive in the Supplier Diversity and Outreach Program or this bid. A notarized letter on each company's letterhead by all Partners of the Engagement stating the percentage relationship towards this bid must be included in the bidder's response or no MWBE pricing incentive calculation will be awarded. The M/WBE pricing incentive calculation is:

SBBC MWBE PARTICIPATION	INCENTIVE MULTIPLIER	EXAMPLE OF SCORE IF ORIGINAL PROPOSED TOTAL PRICE IS \$500,000
≥ 25%	90% or .9	\$ 450,000.00
≥ 23%	91% or .91	\$ 455,000.00
≥ 21%	92% or .92	\$ 460,000.00
≥ 19%	93% or .93	\$ 465,000.00
≥ 17%	94% or .94	\$ 470,000.00
≥ 15%	95% or .95	\$ 475,000.00
≥ 13%	96% or .96	\$ 480,000.00
≥ 11%	97% or .97	\$ 485,000.00
≥ 9%	98% or .98	\$ 490,000.00
≥ 7%	99% or .99	\$ 495,000.00
≥ 5%	100% or 1	\$ 500,000.00

In the event that Proposer/awardee intends to utilize any partners in this engagement, the following will apply:

- Awardee shall not employ any partners in engagement or subcontractor against whom SBBC may have a reasonable objection.
- Awardee shall not be required to employ any partners in engagement or subcontractor against whom contractor has a reasonable objection.
- Awardee shall be fully responsible for all acts and omissions of its partners in engagement or subcontractor and of persons directly or indirectly employed by its subcontractors and of persons for whose acts any of them may be liable to the same extent that Awardee is responsible for the acts and omissions of persons directly employed by it. Nothing in the BID shall create any contractual relationship between any partners in engagement or subcontractor and SBBC or any obligation on the part of SBBC to pay or to see the payment of any monies due any partners in engagement or subcontractor. SBBC may furnish to any partners in engagement or subcontractor evidence of amounts paid to Awardee on account of specific work performed.
- Awardee agrees to bind specifically every partner in engagement or subcontractor to the applicable terms and conditions of the BID for the benefit of SBBC.
- Awardee will not be entitled to subcontract, transfer or assign the performance obligations provided herein to any other party without the prior written consent of SBBC nor shall Awardee be allowed to assign any rights, including monies which may become due under the BID, without the prior written approval of SBBC.

SECTION 5, BID SUMMARY SHEET

**PLEASE USE NEW EXCEL SPREADSHEET
 18-027B BID SUMMARY WORKSHEET
 AVAILABLE FOR DOWNLOAD IN DEMANDSTAR**

The Electronic Bid Summary Worksheet must be submitted as per Special Condition 2 – Bid Submittal, in time for bid opening.

All materials submitted with bids need to be clearly marked with the Bid Number and Title

The electronic file has TWO sections (tabs):

COMPANY REPRESENTATIVE: Bidder is requested to fill out their contact information as per Special Condition 23.

Sample:

Bidder Info	
Company Name	
Company Representative	
Email Address	
Phone Number	

BID SUMMARY WORKSHEET:

This is an Excel spreadsheet that will calculate out the Total Per Bid Line Item and also the Group Total.

Bidder MUST fill out the sheet to offer their corresponding price per unit of measure as stated.

Sample:

Group #	Item	Description	SAP # (For SBBC Use Only)	Estimated Quantity	Unit of Measure	Price Per Unit of Measure	Total \$	Bid Line Item	Group Total
1	A	RACK, REFRIGERATOR ROLL-IN ENCLOSED NON-INSULATED	6001225	4	EACH	\$	-		
1	B	TITLE MISSING	6000129	15	EACH	\$	-		
1	C	RACK, REFRIGERATOR ROLL-IN, OPEN	6001226	10	EACH	\$	-	\$	-

SECTION 6, BID SPECIFICATIONS

In order to be considered for award, Bidders must fill these Bid Specifications Forms and the Electronic Bid Summary Sheet and submit them with their bid, in time for bid opening.

ITEM 1 – TO BE AWARDED AS A GROUP

Item #

1A SAP Number: 6001225

Item Name: RACK, REFRIGERATOR ROLL-IN ENCLOSED NON-INSULATED

Description: Minimum Size: 64-1/2" high x 21-3/4" wide x 25-1/8" depth. Extruded frame fully welded made of non-corrosive hi-tensile aluminum, minimum thickness .10. Bottom frame one-piece construction, minimum thickness .190. For storage of (40) 18" x 26" bun pans. Interlocking extruded size walls with 1-1/2" slide spacing (corrugated walls are not acceptable). Furnish with perimeter bumper, stainless steel or nickel plated door latch and (4) 5" swivel casters, two with brakes. Door to be mounted on three pairs of flag-type (butt) hinges. Door swings 270°. Load capacity 200 lbs. N.S.F. approved.
Unit price to include: Inside delivery, all shipping costs and complete assembly.
Manufacturer's standard warranty will apply.

Approved Brands: Crescor Model 150-1840D, Winholt EC1840-CTLPURC/LC/PEB ONLY

Brand Offered: _____

Model Offered: _____

Warranty Period: _____

Delivery (days ARO): _____

Item #

1B SAP Number: 6000129

Item Name: OPEN BAKERS RACK

Description: Minimum Size: 69-3/4" x 22-7/16" wide x 29-5/8" depth. Super heavy-duty, non-corrosive fully welded construction. Framework of structural Hi-Tensile aluminum extrusions or type 6063 aluminum alloy. Tubing mechanically attached to aluminum runners and welded to form vertical uprights. Casters are attached to heavy duty wheel channel extrusion for extra stability. Runners are 2-1/4" extruded aluminum. Unit designed to accommodate a minimum of nineteen (19) each 18" x 20" sheet pans. Bottom of pan rests on 2-1/4" extruded aluminum .090 thick runners on 3" centers. Runner or pan support is welded to vertical uprights. Four (4) 5" heavy duty swivel casters, two with brakes. For storage of (20) 18" x 26" bun pans on bottom pan angle ledges on 3" centers. Posts are made of extruded aluminum, cross supports welded into frame. Load capacity 800 lbs. N.S.F. approved.
Unit price to include: Inside delivery, all shipping costs and complete assembly.
Manufacturer's standard warranty applies.

Approved Brands: Crescor Model 207-1820-SD, Win-Holt AL-1820/HD/LC ONLY

Brand Offered: _____

Model Offered: _____

Warranty Period: _____

Delivery (days ARO): _____

SECTION 6 - BID SPECIFICATIONS (CONTINUED)

In order to be considered for award, Bidders must fill these Bid Specifications Forms and the Electronic Bid Summary Sheet and submit them with their bid, in time for bid opening.

ITEM 1 – TO BE AWARDED AS A GROUP - CONTINUED

Item #

1C SAP Number: 6001226

Item Name: RACK, REFRIGERATOR ROLL-IN, OPEN

Description: Minimum size: 64-1/2" high x 21-1/4" wide x 25-1/8" depth. Constructed of non-corrosive high tensile aluminum. Fully welded framework for rigidity and strength. Extruded angle ledge pan supports welded in place. Posts and cross supports to be minimum thickness of .125. Heavy-duty 5" swivel plate casters, two with brakes. Accommodates (11) 18" x 26" pans or (22) 14" x 18" trays. Slide spacing 5-1/8". Load capacity 200 lbs.
Unit price to include: Inside delivery and complete assembly.
Manufacturer's standard warranty will apply.

Approved Brands: Crescor Model 207-1818-C, Winholt ALREF1118/64E/XB/LC ONLY

Brand Offered: _____

Model Offered: _____

Warranty Period: _____

**Delivery
(days ARO):** _____

SECTION 6 - BID SPECIFICATIONS (CONTINUED)

In order to be considered for award, Bidders must fill these Bid Specifications Forms and the Electronic Bid Summary Sheet and submit them with their bid, in time for bid opening.

Item #

2 SAP Number: 6000084

Item Name: RACKS, DUNNAGE

Description: 12" high x 21" or 22" deep x 48" wide. One piece, polyethylene construction. Foamed in place for structural strength. Slotted top for air circulation around stored products.
N.S.F. approved.
Cleaning clearance underneath 8-3/4". Load capacity minimum 1500 pounds.
Manufacturer's standard warranty will apply.

Approved Brands: Cambro Model DRS-480, InterMetro Model HP2248PD, Continental Model 5848, Winholt PLSQ-4-1222 ONLY.

Brand Offered: _____

Model Offered: _____

Warranty Period: _____

Delivery (days ARO): _____

SECTION 6 - BID SPECIFICATIONS (CONTINUED)

In order to be considered for award, Bidders must fill these Bid Specifications Forms and the Electronic Bid Summary Sheet and submit them with their bid, in time for bid opening.

ITEM 3 – TO BE AWARDED AS A GROUP

Item #

3 Item Name: SHELVING, ADJUSTABLE FOR DRY STORAGE

Description: Wire shelving, rust resistant epoxy, open wire design. Constructed of heavy gauge carbon steel with a coating process that creates a corrosion resistant finish. Coating finish contains Microban antimicrobial protection from bacteria, mold, etc. Shelves adjustable on 1" increments. Weight capacity of entire shelf 36" or 48" with equal distribution of weight in minimum of 1500 lbs. 10-year limited warranty against rust. Adjustable levelers available for post feet. **NSF approved.**

Unit price to include: Inside delivery, uncrating, removal of packaging materials, four-tier assembly, all shipping costs and installation required. First shelf to be 7" AFF and remaining shelves to be spaced equally.

Approved Brands: InterMetro Metro-Seal, Eagle Group Eaglegard, and Amco ONLY

- 3A SAP Number and Item Size: 6001233, SHELF, 21" Wide X 36" Long**
- 3B SAP Number and Item Size: 6006200, SHELF, 18" Wide x 36" Long**
- 3C SAP Number and Item Size: 6006201, SHELF, 18" Wide x 42" Long**
- 3D SAP Number and Item Size: 6006202, SHELF, 21" Wide x 42" Long**
- 3E SAP Number and Item Size: 6000136, SHELF, 21" Wide X 48" Long (BR)**
- 3F SAP Number and Item Size: 6006203, SHELF, 18" Wide x 48" Long**
- 3G SAP Number and Item Size: 6000137, POST 63" High**
- 3H SAP Number and Item Size: 6004820, POST 75"High**

Brand Offered:

Warranty Period:

**Delivery
(days ARO):**

SECTION 6 - BID SPECIFICATIONS (CONTINUED)

In order to be considered for award, Bidders must fill these Bid Specifications Forms and the Electronic Bid Summary Sheet and submit them with their bid, in time for bid opening.

ITEM 4 – TO BE AWARDED AS A GROUP

Item #

4A SAP Number: 6000095

Item Name: UTILITY CART, THREE SHELVES, SMALL SIZE

Description: Minimum size: 42" high x 18" wide x 32" long. Minimum Shelf size: 32" long x 18" wide and have fully hemmed lips turned down on 4 sides. All shelves with lips turned down. Made from extruded stainless steel tubing welded to stainless steel sheets, 16 gauge 304 stainless steel. Single loop handle made from one piece square stainless tubing welded to shelves. (4) 5" polyurethane swivel casters required, two with brakes. 800 lbs. of load capacity. N.S.F. approved.
Unit price to include inside delivery and complete assembly.
Two (2) year warranty on carts and wheels.

Approved Brands: Win-Holt Model SSUC-3-1832/1H/42H/4LD or other brands meeting bid specifications.

Brand Offered: _____
Model Offered: _____
Warranty Period: _____
Delivery (days ARO): _____

Item #

4B SAP Number: 6000096

Item Name: UTILITY CART, THREE SHELVES, LARGE SIZE

Description: Minimum size: 42" high x 21" wide x 33" long. Minimum Shelf size: 33" long x 21" wide and have fully hemmed lips turned down on all 4 sides. All shelves with lips turned down. Made from extruded stainless steel tubing welded to stainless steel sheets, 16 gauge 304 stainless steel. Single loop handle made from one piece square stainless tubing welded to shelves. (4) 5" polyurethane swivel casters required, two with brakes. 800 lbs. of load capacity.
N.S.F. approved.
Unit price to include inside delivery and complete assembly. Two (2) year warranty on carts and wheels.

Approved Brands: Win-Holt Model SSUC-3-2133/1H/42H/4LD or other brands meeting bid specifications.

Brand Offered: _____
Model Offered: _____
Warranty Period: _____
Delivery (days ARO): _____

SECTION 6 - BID SPECIFICATIONS (CONTINUED)

In order to be considered for award, Bidders must fill these Bid Specifications Forms and the Electronic Bid Summary Sheet and submit them with their bid, in time for bid opening.

ITEM 4 – TO BE AWARDED AS A GROUP - CONTINUED

Item #

4C SAP Number: 6001107

Item Name: STAND, UTILITY

Description: Minimum size: 29" high x 33" wide x 25" long. Shelf size: 24" long x 32" wide. Utility stand is designed for holding, storing and transporting mixers, slicers, grinders and other types of small appliances and accessories. Stand has 18 gauge reinforced top supported by rigid 12 gauge angle legs. (4) 4" swivel casters are required, two with brakes. Easy to clean and sanitize. NSF approved. Unit price to include inside delivery and complete assembly of stand. Manufacturer's standard warranty will apply.

Approved Brands: Lakeside Model 518, and Seco Model SS-16-3033-AX ONLY

Brand Offered: _____

Model Offered: _____

Warranty Period: _____

**Delivery
(days ARO):** _____

SECTION 6 - BID SPECIFICATIONS (CONTINUED)

In order to be considered for award, Bidders must fill these Bid Specifications Forms and the Electronic Bid Summary Sheet and submit them with their bid, in time for bid opening.

ITEM 5 – TO BE AWARDED AS A GROUP

Item #

5A **SAP Number:** **6001148**
Item Name: **CART, UTILITY – SMALL**
Description: Minimum Size: 35 1/2" high x 18 5/6" wide x 31 1/2" long. Shelves to be 3-tier polyethylene, injection molded and 4 chrome plated posts. Shelves designed to resist staining and wipe clean easily. Handle shelf will have integrated utility tray and coved corners. Flat shelves built in 3" cutaway for additional legroom. Sturdy construction: rated at 150 lbs. per shelf. Easy no-tool assembly. (4) 4" non-marking swivel casters. Colors available in black, gray, blue. Cart to include nominal labels for easy identification. Blue model has Microban antimicrobial product protection. Manufacturer's standard warranty will apply. NSF approved. Unit price to include inside delivery and complete assembly.

Approved Brands: InterMetro Model MY1627-34 or other brands meeting bid specifications (Color code may be noted as last character(s) of model number)

Brand Offered: _____
Model Offered: _____
Colors Available: _____
Warranty Period: _____
Delivery (days ARO): _____

Item #

5B **SAP Number:** **6000113**
Item Name: **CART, UTILITY, THREE SHELVES – LARGE**
Description: Minimum size: 35 1/2" high x 27 11/16" wide x 40 1/4" long. Shelves to be 3-tier polyethylene, injection molded and 4 chrome plated posts. Shelves designed to resist staining and wipe clean easily. Handle shelf will have integrated utility tray and coved corners. Flat shelves built in 3" cutaway for additional legroom. Sturdy construction: rated at 150 lbs. per shelf. Easy no-tool assembly. (4) 4" non-marking swivel casters. Colors available in black, gray, blue. Cart to include nominal labels for easy identification. Blue model has Microban antimicrobial product protection. Manufacturer's standard warranty will apply. NSF approved. Unit price to include inside delivery and complete assembly.

Approved Brands: InterMetro Model MY 2636-34 or other brands meeting bid specifications (Color code may be noted as last character(s) of model number)

Brand Offered: _____
Model Offered: _____
Colors Available: _____
Warranty Period: _____
Delivery (days ARO): _____

SECTION 6 - BID SPECIFICATIONS (CONTINUED)

In order to be considered for award, Bidders must fill these Bid Specifications Forms and the Electronic Bid Summary Sheet and submit them with their bid, in time for bid opening.

ITEM 5 – TO BE AWARDED AS A GROUP - CONTINUED

Item #

5C SAP Number: 6000111

Item Name: CART, UTILITY, THREE SHELVES – MEDIUM

Award Type: TO BE AWARDED AS PART OF GROUP ITEM

Description: Minimum size: 35 1/2" high x 23 7/16" wide x 34 3/8" long. Shelves to be 3-tier polyethylene, injection molded and 4 chrome plated posts. Shelves designed to resist staining and wipe clean easily. Handle shelf will have integrated utility tray and covered corners. Flat shelves built in 3" cutaway for additional legroom. Sturdy construction: rated at 150 lbs. per shelf. Impact-resistant surface will not chip, peel or dent. Easy no-tool assembly.
(4) 4" non-marking swivel casters.
Colors available in black, gray, and blue. Cart to include nominal labels for easy identification. Blue model has Microban antimicrobial product protection.
Manufacturer's standard warranty will apply.
NSF approved.
Unit price to include inside delivery and complete assembly.

Approved Brands: InterMetro Model MY2030-34 or other brands meeting bid specifications

Brand Offered: _____

Model Offered: _____

Colors Available: _____

Warranty Period: _____

Delivery (days ARO): _____

SECTION 6 - BID SPECIFICATIONS (CONTINUED)

In order to be considered for award, Bidders must fill these Bid Specifications Forms and the Electronic Bid Summary Sheet and submit them with their bid, in time for bid opening.

ITEM 6 – TO BE AWARDED AS A GROUP

Item #

6A SAP Number: 6000068

Item Name: TABLE, UTILITY – 5’L X 2.5’W X 3”H

Description: See Illustration 6A. 5' long x 2-1/2' wide x 3' high. Tops to be 14 gauge stainless steel with channel edges all sides, no splash. Bull nose edge with marine edge. 18 gauge stainless steel undershelf. Stainless steel legs on casters. One stainless steel roller bearing drawer 20" x 20" x 5" deep. Mounted on 5" swivel number 5-40 126 J & J or equivalent casters, two with vertilok brakes. Overall table top height three feet. All Stainless steel to be 18/8 number 304 with a number four polish. Top 14 gauge, under shelf 18 gauge. Unit must be NSF approved. Unit price to include inside delivery, all shipping costs and complete assembly.

NOTE: For all custom made utility tables, a complete drawing, illustrating the following information, but not limited to, dimensions, sizes, type of materials and accessories, must be furnished for evaluation purposes. Failure to furnish a complete drawing will result in disqualification of bid item.

Manufacturer’s warranty will apply. Inside delivery and set-up required.

Approved Brands: SPG International Model 5-SL-SLS Table with TAC 1-4 casters and TAC 2020-S drawer, Elkay Custom Deluxe Spec-Line Series, Advanced Tabco SS-306, Eagle Group Model T3060SE w/casters & drawer ONLY.

Brand Offered: _____

Model Offered: _____

Warranty Period: _____

Delivery (days ARO): _____

SECTION 6 - BID SPECIFICATIONS (CONTINUED)

In order to be considered for award, Bidders must fill these Bid Specifications Forms and the Electronic Bid Summary Sheet and submit them with their bid, in time for bid opening.

ITEM 6 – TO BE AWARDED AS A GROUP - CONTINUED

Item #

6B SAP Number: 6001110

Item Name: TABLE, UTILITY – 6’L X 2.5’W X 3”H

Description: See Illustration 6B. 6' long x 2-1/2' wide x 3' high. Tops to be 14 gauge stainless steel with channel edges all sides no splash. Stainless steel legs on casters. Bull nose edge with marine edge. 18 gauge stainless steel undershelf. One stainless steel roller bearing drawer 20" x 20" x 5" deep. Mounted on 5" swivel number 5-40 126 J & J casters, two with vertilok brakes. Overall table top height three feet. All Stainless steel to be 18/8 number 304 with a number four polish. Top 14 gauge, under shelf 18 gauge. Unit must be NSF approved. Unit price to include inside delivery, all shipping costs and complete assembly.

NOTE: For all custom made utility tables, a complete drawing, illustrating the following information, but not limited to, dimensions, sizes, type of materials and accessories, must be furnished for evaluation purposes. Failure to furnish a complete drawing will result in disqualification of bid item.

Manufacturer's standard warranty. Inside delivery and set-up required.

Approved Brand: SPG International Model 6-SL-SLS Table with TAC 1-4 casters and TAC 2020-S drawer, Elkay Custom Spec Line, Eagle Group Model T3072SE w/casters & drawer ONLY.

Brand Offered: _____

Model Offered: _____

Warranty Period: _____

Delivery (days ARO): _____

SECTION 6 - BID SPECIFICATIONS (CONTINUED)

In order to be considered for award, Bidders must fill these Bid Specifications Forms and the Electronic Bid Summary Sheet and submit them with their bid, in time for bid opening.

ITEM 7 – TO BE AWARDED AS A GROUP

Item #

7A **SAP Number:** **6006281**
Item Name: **TABLE, WORK – STAINLESS STEEL – 60” LONG – NO CASTERS**
Description: **See Illustration 7A.** Top minimum 14 gauge stainless, under-shelf minimum 18 gauge stainless, **minimum 60" long x 24" wide x 35" high**. Stainless steel legs, no casters. Type 304 stainless steel with under-shelf. NSF approved.

Unit price to include inside delivery and complete assembly. Manufacturer's standard warranty will apply. Inside delivery and set-up required.

Approved Brand: Eagle Model T-2460SE, Gamenza Model T2460 or other brands meeting bid specifications

Brand Offered: _____
Model Offered: _____
Warranty Period: _____
Delivery (days ARO): _____

Item #

7B **SAP Number:** **6000074**
Item Name: **TABLE, WORK - STAINLESS STEEL – 48” LONG – NO CASTERS**
Description: **See Illustration 7B.** Top minimum 14 gauge stainless steel, under shelf minimum 18 gauge stainless steel, minimum **48" long x 24" wide x 35" high**. Stainless Steel legs, no casters. Type 304 stainless steel with under shelf. NSF approved.

Unit price to include inside delivery and complete assembly. Manufacturer's standard warranty will apply. Inside delivery and set-up required.

Approved Brand: Eagle Model T-2448SE, Gamenza Model T4824 or other brands meeting bid specifications

Brand Offered: _____
Model Offered: _____
Warranty Period: _____
Delivery (days ARO): _____

SECTION 6 - BID SPECIFICATIONS (CONTINUED)

In order to be considered for award, Bidders must fill these Bid Specifications Forms and the Electronic Bid Summary Sheet and submit them with their bid, in time for bid opening.

ITEM 7 – TO BE AWARDED AS A GROUP - CONTINUED

Item #

7C **SAP Number:** **6001111**
Item Name: **TABLE, WORK - STAINLESS STEEL – 48” LONG – WITH CASTERS**
Description: **See Illustration 7C.** Top minimum 14 gauge stainless steel, under shelf minimum 18 gauge stainless steel, **minimum 48” long x 24” wide x 35” high.** Stainless Steel legs and 5” swivel, locking casters. Type 304 stainless steel with under shelf. NSF approved.

Unit price to include inside delivery and complete assembly. Manufacturer's standard warranty will apply. Inside delivery and set-up required.

Approved Brand: Eagle Model T-2448SE, Gamenza Model T-4824-C or other brands meeting bid specifications

Brand Offered: _____

Model Offered: _____

Warranty Period: _____
Delivery
(days ARO): _____

Item #

7D **SAP Number:** **6000075**
Item Name: **TABLE, WORK - STAINLESS STEEL – 60” LONG – NO CASTERS**
Description: **See Illustration 7D.** Top minimum 14 gauge stainless steel, under shelf minimum 18 gauge stainless steel, **minimum 60” long x 30” wide x 35” high.** Stainless Steel legs, no casters. Type 304 stainless steel with under shelf. NSF approved.

Unit price to include inside delivery and complete assembly. Manufacturer's standard warranty will apply. Inside delivery and set-up required.

Approved Brand: Eagle Model T-3060SE, Gamenza Model T6030 or other brands meeting bid specifications

Brand Offered: _____

Model Offered: _____

Warranty Period: _____
Delivery
(days ARO): _____

SECTION 6 - BID SPECIFICATIONS (CONTINUED)

In order to be considered for award, Bidders must fill these Bid Specifications Forms and the Electronic Bid Summary Sheet and submit them with their bid, in time for bid opening.

ITEM 7 – TO BE AWARDED AS A GROUP - CONTINUED

Item #

7E **SAP Number:** **6000076**
Item Name: **TABLE, WORK - STAINLESS STEEL – 72” LONG – NO CASTERS**
Description: **See Illustration 7E.** Top minimum 14 gauge stainless steel, under shelf minimum 18 gauge stainless steel, minimum **72” long x 30” wide x 35” high**. Stainless Steel legs, no casters. Type 304 stainless steel with under shelf. NSF approved.

Unit price to include inside delivery and complete assembly. Manufacturer’s standard warranty will apply. Inside delivery and set-up required.

Approved Brand: Eagle Model T-3072SE, Gamenza Model T7230 or other brands meeting bid specifications

Brand Offered: _____
Model Offered: _____
Warranty Period: _____
Delivery (days ARO): _____

Item #

7F **SAP Number:** **6001112**
Item Name: **TABLE, WORK - STAINLESS STEEL – 84” LONG – NO CASTERS**
Description: **See Illustration 7F.** Top minimum 14 gauge stainless steel, under shelf minimum 18 gauge stainless steel, **minimum 84” long x 30” wide x 35” high**. Stainless Steel legs, no casters. Type 304 stainless steel with under shelf. NSF approved.

Unit price to include inside delivery and complete assembly. Manufacturer’s standard warranty will apply. Inside delivery and set-up required.

Approved Brand: Eagle Model T-3084SE, Gamenza Model T8430 or other brands meeting bid specifications

Brand Offered: _____
Model Offered: _____
Warranty Period: _____
Delivery (days ARO): _____

SECTION 6 - BID SPECIFICATIONS (CONTINUED)

In order to be considered for award, Bidders must fill these Bid Specifications Forms and the Electronic Bid Summary Sheet and submit them with their bid, in time for bid opening.

ITEM 7 – TO BE AWARDED AS A GROUP - CONTINUED

Item #

7G **SAP Number:** **6006181**
Item Name: **TABLE, WORK - STAINLESS STEEL – 48” LONG – WITH CASTERS**
Description: **See Illustration 7C.** Top minimum 14 gauge stainless steel, under shelf minimum 18 gauge stainless steel, **minimum 48” long x 30” wide x 35” high.** Stainless Steel legs and 5” swivel, locking casters. Type 304 stainless steel with under shelf. NSF approved.

Unit price to include inside delivery and complete assembly. Manufacturer's standard warranty will apply. Inside delivery and set-up required. *

Approved Brand: Eagle Model T-3048SE, Gamenza Model T-4830-C or other brands meeting bid specifications

Brand Offered: _____

Model Offered: _____

Warranty Period: _____
Delivery
(days ARO): _____

Item #

7H **SAP Number:** **6006182**
Item Name: **TABLE, WORK - STAINLESS STEEL – 36” LONG – WITH CASTERS**
Description: **See Illustration 7C.** Top minimum 14 gauge stainless steel, under shelf minimum 18 gauge stainless steel, **minimum 36” long x 24” wide x 35” high.** Stainless Steel legs and 5” swivel, locking casters. Type 304 stainless steel with under shelf. NSF approved.

Unit price to include inside delivery and complete assembly. Manufacturer's standard warranty will apply. Inside delivery and set-up required.

Approved Brand: Eagle Model T-2436SE, Gamenza Model T-3624-C or other brands meeting bid specifications

Brand Offered: _____

Model Offered: _____

Warranty Period: _____
Delivery
(days ARO): _____

SECTION 6 - BID SPECIFICATIONS (CONTINUED)

In order to be considered for award, Bidders must fill these Bid Specifications Forms and the Electronic Bid Summary Sheet and submit them with their bid, in time for bid opening.

ITEM 7 – TO BE AWARDED AS A GROUP - CONTINUED

Item #

7I **SAP Number:** **6006160**
Item Name: **TABLE, WORK - STAINLESS STEEL – 42” LONG – WITH CASTERS**
Description: **See Illustration 7C.** Top minimum 14 gauge stainless steel, under shelf minimum 18 gauge stainless steel, **minimum 42” long x 30” wide x 35” high**. Stainless Steel legs and 5” swivel, locking casters. Type 304 stainless steel with under shelf. NSF approved.

Unit price to include inside delivery and complete assembly. Manufacturer’s standard warranty will apply. Inside delivery and set-up required.

Approved Brand: Eagle Model T-3042SE, Gamenza Model T-4230-C or other brands meeting bid specific

Brand Offered: _____
Model Offered: _____
Warranty Period: _____
Delivery (days ARO): _____

Item #

7J **SAP Number:** **6006161**
Item Name: **TABLE, WORK - STAINLESS STEEL – 36” LONG – WITH CASTERS**
Description: **See Illustration 7C.** Top minimum 14 gauge stainless steel, under shelf minimum 18 gauge stainless steel, minimum **36” long x 30” wide x 35” high**. Stainless Steel legs and 5” swivel, locking casters. Type 304 stainless steel with under shelf. NSF approved.

Unit price to include inside delivery and complete assembly. Manufacturer’s standard warranty will apply. Inside delivery and set-up required.

Approved Brand: Eagle Model T-3036SE, Gamenza Model T-3630-C or other brands meeting bid specifications

Brand Offered: _____
Model Offered: _____
Warranty Period: _____
Delivery (days ARO): _____

SECTION 6 - BID SPECIFICATIONS (CONTINUED)

In order to be considered for award, Bidders must fill these Bid Specifications Forms and the Electronic Bid Summary Sheet and submit them with their bid, in time for bid opening.

ITEM 7 – TO BE AWARDED AS A GROUP - CONTINUED

Item #

7K SAP Number: 6006210

Item Name: TABLE, WORK – STAINLESS STEEL – 42” LONG – NO CASTERS

Description: See Illustration 7A. Top minimum 14 gauge stainless, under-shelf minimum 18 gauge stainless, **minimum 42" long x 24" wide x 35" high**. Stainless steel legs, no casters. Type 304 stainless steel with under-shelf. NSF approved.

Unit price to include inside delivery and complete assembly. Manufacturer's standard warranty will apply. Inside delivery and set-up required.

Approved Brand: Eagle Model T-2442SE, Gamenza Model T-2442 or other brands meeting bid specifications

Brand Offered: _____

Model Offered: _____

Warranty Period: _____
Delivery
(days ARO): _____

Item #

7L SAP Number: 6000073

Item Name: TABLE, WORK – STAINLESS STEEL – 60” LONG – WITH CASTERS

Description: See Illustration 7A. Top minimum 14 gauge stainless, under-shelf minimum 18 gauge stainless, **minimum 60" long x 24" wide x 35" high**. Stainless Steel legs and 5" swivel, locking casters. Type 304 stainless steel with under-shelf. NSF approved.

Unit price to include inside delivery and complete assembly. Manufacturer's standard warranty will apply. Inside delivery and set-up required.

Approved Brand: Eagle Model T-2460SE, Gamenza Model T-2460-C or other brands meeting bid specifications

Brand Offered: _____

Model Offered: _____

Warranty Period: _____
Delivery
(days ARO): _____

SECTION 6 - BID SPECIFICATIONS (CONTINUED)

In order to be considered for award, Bidders must fill these Bid Specifications Forms and the Electronic Bid Summary Sheet and submit them with their bid, in time for bid opening.

ITEM 7 – TO BE AWARDED AS A GROUP - CONTINUED

Item #

7M SAP Number: 6006162

Item Name: TABLE, WORK – STAINLESS STEEL – 48” LONG – NO CASTERS

Description: See Illustration 7A. Top minimum 14 gauge stainless, under-shelf minimum 18 gauge stainless, **minimum 48" long x 30" wide x 35" high**. Stainless steel legs, no casters. Type 304 stainless steel with under-shelf. NSF approved.

Unit price to include inside delivery and complete assembly. Manufacturer's standard warranty will apply. Inside delivery and set-up required.

Approved Brand: Eagle Model T-3048SE, Gamenza Model T-3048 or other brands meeting bid specifications

Brand Offered: _____

Model Offered: _____

Warranty Period: _____

Delivery (days ARO): _____

SECTION 6 - BID SPECIFICATIONS (CONTINUED)

In order to be considered for award, Bidders must fill these Bid Specifications Forms and the Electronic Bid Summary Sheet and submit them with their bid, in time for bid opening.

Item #

8 SAP Number: 6001106

Item Name: TABLE FOR BAKER'S SCALE

Description: See Illustration 8. Counter-top model, 24" x 24" square. All welded stainless construction. 14-gauge 304 stainless steel top with marine edge. Top reinforced with stainless steel hat channels. Undershelf 14 gauge type 304 stainless steel. Stainless steel gussets. Legs to be 1-5/8" round stainless steel tubing with 1" adjustable stainless steel clad feet. Legs inserted and welded into hat channel.

Manufacturer's standard warranty will apply. Unit price to include complete assembly and inside delivery (placement of table). Inside delivery and set-up required.

Approved Brand: Winholt EX/MX2424/14GA or other brands meeting bid specifications

Brand Offered: _____

Model Offered: _____

Warranty Period: _____

Delivery (days ARO): _____

SECTION 6 - BID SPECIFICATIONS (CONTINUED)

In order to be considered for award, Bidders must fill these Bid Specifications Forms and the Electronic Bid Summary Sheet and submit them with their bid, in time for bid opening.

ITEM 9 – TO BE AWARDED AS A GROUP

Item #

9A SAP Number: 6001079

Item Name: OVEN, STACK PIZZA CONVEYOR – 120-208 VOLT

Description: **Two ovens** stacked with separate electrical controls per oven. High production induction or jet air conveyor oven. Jets of high velocity hot air delivered to food. Oven to have adjustable forced air diffusers or air fingers to distribute heat evenly. Digital temperature display and conveyor speed controls. Controls must have an emergency stop switch. Stainless steel interior. Each separate cooking section to have a minimum chamber clearance of 18-3/4" wide X 3-1/2" high to accommodate 18" X 26" sheet pans. Minimum 18" wide stainless steel wire belt. Adjustable conveyor speed and reversible direction. Overall footprint of oven not to exceed: 70" long X 47" wide.

Oven must include:

- Stainless steel removable exit shelf – two per each oven
- Stainless steel entrance shelf – two per each oven
- Stainless removable crumb trays two per each oven
- Type 304 stainless steel stand, 1" square tubing, four swivel/locking casters
- Conveyor ovens stacked at factory and shipped fully assembled.

Electrical: 120-208V/60 Hz/3 Phase. 36-38 amps (approx.) per oven. **Warranty: Two year manufacturer's warranty, all parts and labor must be included in the unit price. Demonstration of equipment shall be required, at school cafeteria location, by a factory representative, for a minimum of one lunch period after delivery of equipment. UL listed.** Price must include inside delivery and complete operational setup and demonstration.

Approved Brands: Lincoln Model 1132 w/part #1121-1 and 2 each part #1140 with stainless steel interior or other brands meeting bid specifications

Brand Offered: _____

Model Offered: _____

Warranty Period: _____
Delivery
(days ARO): _____

Item #

9B SAP Number: 6002199

Item Name: OVEN, STACK PIZZA CONVEYOR – 480 VOLT

Description: Same as 9A, except 480 volt, 3 Phase.
Approved Brands: Lincoln Model 1135 w/part #1121-1 and 2 each part #1140 or other brands meeting bid specifications

Brand Offered: _____

Model Offered: _____

Warranty Period: _____
Delivery
(days ARO): _____

SECTION 6 - BID SPECIFICATIONS (CONTINUED)

In order to be considered for award, Bidders must fill these Bid Specifications Forms and the Electronic Bid Summary Sheet and submit them with their bid, in time for bid opening.

ITEM 10 – TO BE AWARDED AS A GROUP

Item #

10A SAP Number: 6001252

Item Name: COOLER, MILK – 8 CRATES

Description: COOLER, MILK – 8 CRATES

Drop front style cooler, all stainless steel Type 300 stainless front, top, sides, doors and interior. Storage capacity 8 crates (13" x 13" x 11"). Stainless steel floor on top of minimum of 18 gauge galvanized steel with heavy-duty floor rack. Foamed-in-place polyurethane minimum 1-5/8" high-density insulated door. Self contained refrigeration system, no plumbing required. 4" – 5" heavy-duty swivel casters, 2 with brakes. Cylinder lock or pad lock for security. Nema 5-15P cord/cap, minimum cord length 8 feet. **NSF and UL approved. Warranty: Two year manufacturer's warranty, all parts and labor, 5 years on compressor must be included in unit price.** Price must include inside delivery and complete operational setup.

Approved Brands: True Mfg. Model TMC-34-S-SS with s/s interior, Mod-U-Serve Model MCT-SM1, Norlake Model ARO82SSS/O, Beverage Air Model SMF34-S ONLY.

Brand Offered: _____

Model Offered: _____

Warranty Period: _____
Delivery (days ARO): _____

Item #

10B SAP Number: 6001253

Item Name: COOLER, MILK – 12 CRATES

Description:

Drop front style cooler, all stainless steel Type 300 stainless front, top, sides, doors and interior. Storage capacity 12 crates (13" x 13" x 11"). Stainless steel floor on top of minimum of 18 gauge galvanized steel with heavy-duty floor rack. Foamed-in-place polyurethane minimum 1-5/8" high-density insulated door. Self contained refrigeration system, no plumbing required. 4" – 5" heavy-duty swivel casters, 2 with brakes. Cylinder lock or pad lock for security. Nema 5-15P cord/cap, minimum cord length 8 feet. **NSF and UL approved. Warranty: Two year manufacturer's warranty, all parts and labor, 5 years on compressor must be included in unit price.** Price must include inside delivery and complete operational setup.

Approved Brands: True Mfg. Model TMC-49-S-SS with s/s interior, Mod-U-Serve Model MCT-SM2, Norlake Model ARO122SSS/O, Beverage Air Model SMF49-S ONLY.

Brand Offered: _____

Model Offered: _____

Warranty Period: _____
Delivery (days ARO): _____

SECTION 6 - BID SPECIFICATIONS (CONTINUED)

In order to be considered for award, Bidders must fill these Bid Specifications Forms and the Electronic Bid Summary Sheet and submit them with their bid, in time for bid opening.

ITEM 10 – TO BE AWARDED AS A GROUP - CONTINUED

Item #

10C SAP Number: 6001335

Item Name: COOLER MILK – 16 CRATES

Description: Drop front style cooler, all stainless steel Type 300 stainless front, top, sides, doors and interior. Storage capacity 16 crates (13" x 13" x 11"). Stainless steel floor on top of minimum of 18 gauge galvanized steel with heavy-duty floor rack. Foamed-in-place polyurethane minimum 1-5/8" high-density insulated door. Self-contained refrigeration system, no plumbing required. 4" – 5" heavy-duty swivel casters, 2 with brakes. Cylinder lock or pad lock for security. Nema 5-15P cord/cap, minimum cord length 8 feet. **NSF and UL approved.**

Warranty: Two year manufacturer's warranty, all parts and labor, 5 years on compressor must be included in the unit price. Price must include inside delivery and complete operational setup.

**Approved Brands: True Mfg. Model TMC-58-S-SS with s/s interior,
Mod-U-Serve Model MCT-SM3, Norlake Model ARO162SSS/O,
Beverage Air Model SMF58-S**

Brand Offered: _____

Model Offered: _____

Warranty Period: _____

**Delivery
(days ARO):** _____

SECTION 6 - BID SPECIFICATIONS (CONTINUED)

In order to be considered for award, Bidders must fill these Bid Specifications Forms and the Electronic Bid Summary Sheet and submit them with their bid, in time for bid opening.

ITEM 11 – TO BE AWARDED AS A GROUP

Item #

11A SAP Number: 6002182
Item Name: RANGE, EXPANDO COOKING – ELECTRIC – 208 VOLT
Description: All-purpose two-burner range. Front, exterior bottom including base channel, and fastening devices to be all stainless steel. Top shall have two 9" solid, round cast iron hot plates with formed tubular heating element. Grease troughs on front and back of cooking area or porcelain enamel grease drawer under cook top. Internal limit overload protection available only on 208 volt units. Working height to be 36" or 37" high x 12" wide x 36" to 38" front to rear. 208 volt, one phase.
Service manual, parts list, and wiring diagrams must accompany each delivered unit.
Warranty: Two-year manufacturer's warranty, all parts and labor must be included in the unit price.
Unit Price must include uncrate, set in place & level, remove plastic, provide service manuals, schematic diagrams and on-site demonstration for each delivered unit.
Approved Brand: Vulcan-Hart Model EV 12-FP208 ONLY
Brand Offered: _____
Model Offered: _____
Warranty Period: _____
Delivery (days ARO): _____

Item #

11B SAP Number: 6002183
Item Name: RANGE, EXPANDO COOKING – ELECTRIC – 480 VOLT
Description: Same as 11A, except 480 volt, three phase.
Approved Brand: Vulcan-Hart Model EV 12 – FP480 ONLY
Brand Offered: _____
Model Offered: _____
Warranty Period: _____
Delivery (days ARO): _____

SECTION 6 - BID SPECIFICATIONS (CONTINUED)

In order to be considered for award, Bidders must fill these Bid Specifications Forms and the Electronic Bid Summary Sheet and submit them with their bid, in time for bid opening.

Item #

12 SAP Number: 6001227

Item Name: RANGE, EXPANDO COOKING – GAS FIRED (LP OR NATURAL)

Description: All purpose hot top range. Two open burners (35,000 BTU each). Front, exterior bottom including base channel, and fastening devices to be all stainless steel. Unit to be no greater than 17" wide, and a 27" cooking surface depth. Unit to have 27" deep cooking surface, total depth of unit not to exceed 38". 10" stainless steel low profile back guard. Front and cap, rear gas connection. Removable ring grates over each burner. Automatic Burner ignition.
National Sanitation Foundation (NSF) and Canadian Standards Association (CSA) approved.
Service manual, parts list, and wiring diagram must accompany each unit.
Warranty: Two-year manufacturer's warranty, all parts and labor must be included in the unit price. INSTALLATION REQUIRED.

Approved Brand: Garland Model M4S or other brands meeting bid specifications

Brand Offered: _____

Model Offered: _____

Warranty Period: _____

**Delivery
(days ARO):** _____

SECTION 6 - BID SPECIFICATIONS (CONTINUED)

In order to be considered for award, Bidders must fill these Bid Specifications Forms and the Electronic Bid Summary Sheet and submit them with their bid, in time for bid opening.

ITEM 13 – TO BE AWARDED AS A GROUP

Item #

13A SAP Number: 6000133

Item Name: KETTLE, STEAM JACKET – ELECTRIC – 208 VOLT

Description: Electrically heated completely automatic, self-contained 2/3 jacketed steam kettle. Capacity 40 gallons, solid one piece welded construction, outer sheathing air or fiber insulated. Overall height not to exceed 38". Stainless steel, type 304, inside finish to be polished. Exterior of kettle shall be finished to a #3 finish, ensuring maximum ease in cleaning and maintaining brilliant appearance. Type 316 stainless steel kettle liner. Kettle furnished with a sanitary tangent draw-off 2" diameter made of stainless steel complete with 1/8" removable perforated strainer. Reinforced bar rim for kettle stability. All controls shall be contained in a stainless steel enclosure within easy reach of operator. Controls include a thermostat, pilot light, pressure/vacuum gauge, contactor, water level sight glass, safety valve, and low water cut-off. Temperatures controlled from 150° to 270° F. and with a working steam pressure of up to 30 PSI. KW rating not to exceed 24 KW at 208 volt for this unit. Contactors and relay to be mounted onto side of unit. Complete with single hole deck mount faucet, 12" swing nozzle, 44" flex hose, spray value, 6" wall bracket, and ½" male inlet, T&S model 5PR-1S12. Unit mounted on stainless steel legs. Unit to be NSF approved. Service manual, parts list, and wiring diagrams must accompany each delivered unit. 208 Volt, 3 phase.

Warranty: Three year manufacturer's warranty on all parts and labor must be included in the unit price. Include optional faucet and sprayer within the unit price.

Unit Price must include uncrate, set in place & level, remove plastic, factory start-up, service manuals, schematic diagrams, and on-site demonstration for each delivered unit.

Approved Brand: Groen Model EE40 ONLY

Brand Offered: _____

Model Offered: _____

Warranty Period: _____
Delivery
(days ARO): _____

Item #

13B SAP Number: 6001232

Item Name: KETTLE, STEAM JACKET – ELECTRIC – 480 VOLT

Description: Same as 13A, except 480 volt, three phase.

Approved Brand: Groen Model EE40 ONLY

Brand Offered: _____

Model Offered: _____

Warranty Period: _____
Delivery
(days ARO): _____

SECTION 6 - BID SPECIFICATIONS (CONTINUED)

In order to be considered for award, Bidders must fill these Bid Specifications Forms and the Electronic Bid Summary Sheet and submit them with their bid, in time for bid opening.

Item #

14 SAP Number: 6001230

Item Name: KETTLE, STEAM JACKET – GAS FIRED – (LP OR NATURAL)

Description: Self-contained, completely automatic, 2/3-jacketed stainless steel kettle, operating from gas heated steam source contained within unit. Capacity 40 gallons, (W) approximately 43", and overall height not to exceed 41". Solid one piece welded construction. Type 316 stainless steel, inside finish to be polished, outside jacket stainless steel with stainless steel legs. Type 316 stainless steel kettle liner. Outer sheathing air or fiber insulated. Kettle furnished with a sanitary tangent draw-off 2" diameter made of stainless steel. Drain outlet shall be equipped with a removable 1/8" perforated stainless steel strainer. Reinforced bar rim for kettle stability. Temperatures controlled from 150° to 270° F. and with a working steam pressure of up to 30 PSI. All controls shall be contained in a stainless steel enclosure. Controls to include regulating thermostat, power-ON switch, Power-On indicator light, heat indicator light, low water indicator light, low water cut-off, pressure limit regulator, pressure gauge, a gas regulator valve and electronic ignition module, water level sight glass; with all operating controls front mounted. Complete with single hole deck mount faucet, 12" swing nozzle, 44" flex hose, spray valve, 6" wall bracket, and 1/2" male inlet, T & S model 5PR-1S12. Unit requires 1/2" NPT gas line and 115V electric supply to operate controls.

Unit to be National Sanitation Foundation (NSF) and Canadian Standards Association (CSA) approved.

Service manual, parts list, and wiring diagrams must accompany each delivered unit.

Warranty: Three year manufacturer's warranty on all parts and labor must be included in the unit price.

Include optional faucet and sprayer within the unit price.

Approved Brand: Groen Model AH/1-40 ONLY

Brand Offered: _____

Model Offered: _____

Warranty Period: _____

Delivery (days ARO): _____

SECTION 6 - BID SPECIFICATIONS (CONTINUED)

In order to be considered for award, Bidders must fill these Bid Specifications Forms and the Electronic Bid Summary Sheet and submit them with their bid, in time for bid opening.

ITEM 15 – TO BE AWARDED AS A GROUP

Item #

15A SAP Number: 6000813

Item Name: REFRIGERATOR, TWO-DOOR, TWO SECTION

Description: Construction to be stainless steel exterior door, front, sides, & interior floor. Aluminum interior side walls and back. 20 gauge stainless steel door & door interior. Foamed-in-Place Polyurethane Insulation throughout. Front shroud to lift up for easy access to clean condenser coil. Refrigeration to be R-134a or R290 where available. Top mount refrigeration system. All-in-one SIMPLE controller with maximum of 4 parameters that is pre-programmed from the factory. Four sensors on front controller to include temp setting, manual defrost, and lockout. Exterior digital temperature display; automatic LED lighting with door switch. Durable removable snap-in magnetic gasket. Self-closing door with stay open feature. Lifetime guarantee on ergonomic door handle and cam-lift door hinges. Heavy duty cylinder or bolt locks with lifetime warranty. One door to have three (3) heavy-duty, epoxy coated or chrome shelves. One door complete with a minimum of 12 sets of universal tray/pan slides on 4" centers to accept bottom support 18" x 26" pans and 12" x 20" pans. All condensate water is disposed of automatically by the energy efficient, non-electric condensate evaporator. Condenser coil to be out of food zone. If expansion valve system Compressor to have high-pressure cut-off switch. If a capillary tube system then system must be oversized and balanced for quick recovery and pull down. Maintains temperatures of 33 degrees – 38 degrees. Inside storage capacity to be a minimum of 46 useable cubic feet. Heavy-duty 5" polyurethane plate casters, two with brakes. Size: Maximum height 84-1/4" on wheels, depth 35", length 52-53". 115V/60Hz/1 phase, amp draw not to exceed 11.0 with 9' or 10' Nema 5-15P cord/cap. NSF and UL approved.

Warranty: Three year manufacturer’s warranty, all parts and labor, five years for compressor must be included in the unit price. Warranty on compressor to be completely handled by service company for 5 years.

Price to include uncrate, set in place, removal of cartons, installation of shelves and clips, pan slides and casters, plug in and make ready for use.

Must ship from factory within 4 weeks of receipt of purchase order.

Approved Brand: Victory Model RSA-2D-S1, TRUE STA2R-2S with 2 each #3 accessory kits for 1 door or other brands meeting bid specifications

Brand Offered: _____

Model Offered: _____

Warranty Period: _____

Delivery (days ARO): _____

SECTION 6 - BID SPECIFICATIONS (CONTINUED)

In order to be considered for award, Bidders must fill these Bid Specifications Forms and the Electronic Bid Summary Sheet and submit them with their bid, in time for bid opening.

ITEM 15 – TO BE AWARDED AS A GROUP - CONTINUED

Item #

15B SAP Number: 6000814

Item Name: REFRIGERATOR, THREE-DOOR, THREE SECTION

Description: Construction to be stainless steel exterior door, front, sides, & interior floor. Aluminum interior side walls and back. 20 gauge stainless steel door & door interior liner. Front shroud to lift up for easy access to clean condenser coil. Refrigeration to be R-134a or R290 where available, foamed-in-place polyurethane insulation throughout. Top mount refrigeration system. All-in-one SIMPLE controller with maximum of 4 parameters that is pre-programmed from the factory. Four sensors on front controller to include temp. setting, manual defrost, and lockout. Exterior digital temperature display; automatic LED interior light with door switch. Durable removable magnetic snap-in gasket with 2 year warranty. Self-closing door with stay open feature. Lifetime guarantee on ergonomic door handle and cam-lift door hinges. Heavy duty cylinder or bolt locks with lifetime warranty. Two doors to have three (3) heavy-duty, epoxy coated or chrome shelves. One door complete with a minimum of 12 sets of universal tray/pan slides on 4" centers to accept bottom support 18" x 26" pans and 12" x 20" pans. All condensate water is disposed of automatically by the energy efficient, non-electric condensate evaporator. Condenser coil to be out of food zone. If expansion valve system, Compressor to have high-pressure cut-off switch. If a capillary tube system, then system must be oversized and balanced for quick recovery and pull down. Inside storage capacity to be a minimum of 70.09 useable cubic feet. Refrigerator to include the following options: heavy-duty 5" polyurethane plate casters, two with brakes, Maximum height 84-1/4" on casters, max. depth 35". Length 76-78". 115V/60Hz/1 phase, amp draw not to exceed 11.0 with 9' or 10' Nema 5-15P cord/cap. NSF and UL approved.

Warranty: Three year manufacturer's warranty, five years for compressor must be included in the unit price. Warranty on compressor to be completely handled by service company for 5 years.

Price to include uncrate, set in place, removal of plastic and cartons, installation of shelves and clips, plug in, and make ready for use.

Must ship from factory within 4 weeks of receipt of purchase order.

Approved Brands: Victory Model RSA-3D-S1, TRUE STA3R-3S with 2 each #3 accessory kits for 1 door or other brands meeting bid specifications

Brand Offered: _____

Model Offered: _____

Warranty Period: _____

Delivery (days ARO): _____

SECTION 6 - BID SPECIFICATIONS (CONTINUED)

In order to be considered for award, Bidders must fill these Bid Specifications Forms and the Electronic Bid Summary Sheet and submit them with their bid, in time for bid opening.

ITEM 16 – TO BE AWARDED AS A GROUP

Item #

16A SAP Number: 6000069

Item Name: CABINET, WARMING – ONE DOOR, ROLL THROUGH – 208 VOLT

Description: Cabinet insulation to be polyurethane foam. Construction to be stainless exterior and aluminum interior with stainless steel floor and s/s ramps. 20 gauge stainless steel door & door interior line. Front shroud to lift up for easy access to clean condenser coil. Foamed in place polyurethane insulation. Durable removable magnetic snap-in gasket with 2 year warranty. Self-closing door with stay open feature. Lifetime guarantee on ergonomic door handle and cam-lift door hinges. Heavy duty cylinder or bolt locks with lifetime warranty. Clear inside door openings to be minimum of 27-1/4" wide x 66-1/4" high allowing use of 27" wide x 29" deep x 64.5" high mobile racks. Rack offered must fit inside cabinet. Furnish with UL approved automatic 1500 watt heating system. 115/208/240/60/1 or 208/60/1. Include power indicator light, and digital thermometer. **Unit is to be National Sanitary Foundation (NSF) and Underwriter's Laboratories (UL) approved.** To include one fully welded rack of structural aluminum designed for fit in pass-through warmers. Rack must have 18 extruded angle ledge to hold bottom of pan with heavy duty 5" plate casters, 2 with brakes. Must hold food temperatures at 140° - 180°. Height not to exceed 84".
Warranty: Three year manufacturer's warranty on all parts and labor must be included in the unit price. Price to include set up which includes uncrate, set in place, removal of plastic on unit and removal of cartons.

Vendor responsible for leveling cabinet and **caulking or sealing to floor upon delivery to the schools.** Wheels of rack must fit inside door with door closed. Installation of unit must be leveled and shimmed if necessary and sealed to the floor.

Approved Brands: Victory Model HISA-1D-1-PT , True Model STA1HRT-1S-1S with Rack – Crescor Model 207-1818C or New Age Model 1335 or other brands meeting bid specifications

Brand Offered: _____

Model Offered: _____

Rack Offered: _____

Warranty Period: _____

Delivery (days ARO): _____

SECTION 6 - BID SPECIFICATIONS (CONTINUED)

In order to be considered for award, Bidders must fill these Bid Specifications Forms and the Electronic Bid Summary Sheet and submit them with their bid, in time for bid opening.

ITEM 16 – TO BE AWARDED AS A GROUP - CONTINUED

Item #

16B SAP Number: 6006231

Item Name: CABINET, WARMING – TWO DOOR, ROLL THROUGH – 208 VOLT

Award Type: TO BE AWARDED AS PART OF GROUP ITEM

Description: Cabinet insulation to be polyurethane foam. Construction to be stainless **exterior and aluminum interior with stainless steel floor and s/s ramps. 20 gauge stainless steel door & door interior line. Front shroud to lift up for easy access to clean condenser coil. Foamed in place polyurethane insulation. Durable removable magnetic snap-in gasket with 2 year warranty.** Self-closing door with stay open feature. Lifetime guarantee on ergonomic door handle and cam-lift door hinges. Heavy duty cylinder or bolt locks with lifetime warranty. Height not to exceed 84 ¼" to fit in wall cut-out. Clear inside door openings to be minimum of 27 ¼" wide x 66 ¼" high allowing use 27" wide x 29" deep x 64.5" high mobile racks. To include 2 each fully welded racks of structural aluminum designed for fit in pass-through warmers. Rack must have 18 extruded angle ledge to hold bottom of pan with heavy duty 5" plate casters, 2 with brakes. Furnish with UL approved automatic 1500 watt heating system. 115/208-240/60 or 208/60/1. Include power indicator light and digital thermometer. Unit is to be National Sanitary Foundation (NSF) and Underwriter's Laboratories (UL) approved.

Warranty: Three year manufacturer's warranty on all parts and labor must be included in the unit price. Price to include set up which includes uncrate, set in place, removal of plastic on unit and removal of cartons.

Vendor responsible for leveling cabinet and **caulking or sealing to floor upon delivery to the schools.** Wheels of rack must fit inside door with door closed. Installation of unit must be leveled and shimmed if necessary and sealed to the floor.

Approved Brands: Victory Mode HISA-2D-1PT, True Model STA2HRT-2S-2S with Rack – Crescor Model 207-1818C or New Age Model 1335 or other brands meeting bid specifications

Brand Offered: _____

Model Offered: _____

Rack Offered: _____

Warranty Period: _____

Delivery (days ARO): _____

SECTION 6 - BID SPECIFICATIONS (CONTINUED)

In order to be considered for award, Bidders must fill these Bid Specifications Forms and the Electronic Bid Summary Sheet and submit them with their bid, in time for bid opening.

Item #

17 SAP Number: 6001334

Item Name: REFRIGERATOR, TWO DOOR, ROLL-THROUGH WITH FULL DOORS

Description: Two-door roll-through refrigerator with full doors. Construction to be stainless steel exterior and aluminum interior with stainless steel floor and s/s ramps. 20 gauge stainless steel door & door interior liner. Foamed in place polyurethane insulation. Refrigeration to be R-134A or R290 where available. Durable removable magnetic snap-in gasket with. Self-closing door with stay open feature. Lifetime guarantee on ergonomic door handle and cam-lift door hinges. Heavy duty cylinder or bolt locks with lifetime warranty. Each door opening accepts mobile storage rack 27" w x 29" d x 64.5" high. All-in-one SIMPLE controller with maximum of 4 parameters that are pre-programmed from the factory. Four sensors on front controller to include temp. setting, manual defrost and lockout. Exterior digital temperature display; automatic LED interior light with door switch. All condensate water is disposed of automatically by the energy efficient, non-electric condensate evaporator. No plumbing required. Power supply at top. Provide evaporator coil out of food zone. Condensing unit top mounted, air-cooled. If a capillary tube system, then system must be oversized and balanced for quick recovery and pull down. Maximum height of 84 - 1/4", max. depth 36 5/8", and length 68"-69". Voltage to be 115/60/1 with 1/2 - 3/4 H.P. Compressor. Amp draw not to exceed 11.0 with 9' or 10' Nema 5-15P cord/cap. Upper end panels shall be removable allowing accessibility for service from front or sides. Unit is to be National Sanitary Foundation (NSF) and Underwriter's Laboratories (UL) listed.

Warranty: Three year manufacturer's warranty on all parts and labor with warranty, five years on compressor must be included in the unit price.

Awardee must provide parts list, service manual, and schematics with each delivered unit. Ship with UL approved six-foot cord and plug set. Furnish with two roll-in racks all welded construction w/stem casters and universal pan slides.

Set up includes uncrate, set in place, removal of cartons and removal of plastic on unit. Unit must be leveled and shimmed if necessary unit to be sealed to the floor. Bidder is responsible for leveling unit and caulk around perimeter to seal to floor, and verifying clearance of all doors leading to kitchen **upon delivery to the schools.**

Approved Brands: REFRIGERATOR - Victory Model RISA-2D-S1-PT 7 or TRUE STA2RRT-2S-2S with RACKS – Crescor Model 207-1818C or New Age Model 1335 or other brands meeting bid specifications.

Brand Offered: _____

Model Offered: _____

Rack Offered: _____

Warranty Period: _____

Delivery (days ARO): _____

SECTION 6 - BID SPECIFICATIONS (CONTINUED)

In order to be considered for award, Bidders must fill these Bid Specifications Forms and the Electronic Bid Summary Sheet and submit them with their bid, in time for bid opening.

Item #

18 SAP Number: 6000810

Item Name: FREEZER, REACH-IN, SELF-CONTAINED, THREE DOOR

Description: Freezer construction to be stainless steel exterior door, front, sides, & interior floor. Aluminum interior side walls and back. 20 gauge stainless steel door. Unit must have reinforced bottom to withstand heavy loads. Foamed-in-Place Polyurethane Insulation throughout. Front shroud to lift up for easy access to clean condenser coil. Maintains temperatures of -5 degrees. Refrigeration to be R-404a or R290 where available. Top mount refrigeration system with expansion valve. Capacity: minimum 70 cu. ft. of usable space. Heavy duty 5" polyurethane plate casters, 2 with brakes. Each compartment shall have a chrome or stainless steel floor rack. Self-closing door with stay open feature. Lifetime guarantee on ergonomic door handle and cam-lift hinges. Heavy duty cylinder or bolt locks with lifetime warranty. All-in-one SIMPLE controller with maximum of 4 parameters that is pre-programmed from the factory. Four sensors on front controller to include temp. setting, manual defrost, and lockout. Exterior digital temperature display; automatic LED lighting with door switch. Durable removable magnetic snap-in gasket. Anti-condensate door perimeter heaters.

Non-electric condensate evaporator top mounted that disposes of water automatically with pan of sufficient size to accommodate condensation. No plumbing required. Power supply at top. Provide evaporator coil out of food zone.

Furnished with nine heavy-duty epoxy coated or chrome shelves, three per door to accommodate 18" x 26" sheet pans in each full door. Size: Maximum height 84-1/4" high, max. depth 35", length 76 - 78". Electrical: 208/230/60/1, not to exceed 14.0 AMPS. Condensing unit 3/4 HP. Unit to be NSF and UL listed.

Warranty: Three year manufacturer's warranty on all parts and labor plus warranty against condensation build up, five year warranty parts and labor on compressor must be included in the unit price. Warranty on compressor to include shipping and pick up of old compressor upon phone call to factory.

Set-up will include installation of shelves and clips and installation of wheels. Uncrated and remove crate. Unit must be shipped with parts manual and schematics to each location.

Approved Brand: Victory Model FSA-3D-S1 or other brands meeting bid specifications

Brand Offered: _____

Model Offered: _____

Warranty Period: _____

Delivery (days ARO): _____

SECTION 6 - BID SPECIFICATIONS (CONTINUED)

In order to be considered for award, Bidders must fill these Bid Specifications Forms and the Electronic Bid Summary Sheet and submit them with their bid, in time for bid opening.

Item #

19 SAP Number: 6000811

Item Name: FREEZER, REACH-IN, SELF-CONTAINED – TWO DOOR

Description: Freezer construction to be stainless steel exterior door, front, sides, & interior floor. 20 gauge stainless steel door. Unit must have reinforced bottom to withstand heavy loads. Aluminum interior side walls and back. Foamed-in-Place Polyurethane Insulation throughout. Front shroud to lift up for easy access to clean condenser coil. Maintains temperatures of -5 degrees. Refrigeration to be R-404a or R290 where available. Top mount refrigeration system with expansion valve. Capacity: minimum 46.5 cu. ft. of usable space. Heavy duty 5" polyurethane plate casters, 2 with brakes. Each compartment shall have a chrome floor rack.

Self-closing door with stay open feature. Lifetime guarantee on ergonomic door handle and cam-lift hinges. Heavy duty cylinder or bolt locks with lifetime warranty, all doors keyed alike. All-in-one SIMPLE controller with maximum of 4 parameters that is pre-programmed from the factory. Four sensors on front controller to include temp. setting, manual defrost, and lockout. Exterior digital temperature display; automatic LED lighting with door switch. Durable removable magnetic snap-in gasket. Breaker strips shall leave no exposed electrical heating elements and securely installed around entire perimeter of front frame and mullions of all door openings.

Non-electric condensate evaporator top mounted that disposes of water automatically with pan of sufficient size to accommodate condensation. No plumbing required. Power supply at top. Provide evaporator coil out of food zone.

Furnish with six heavy-duty epoxy coated or chrome shelves, to-accommodate 18" x 26" pans, three per door. Size: Maximum height 84-1/4" high on wheels, max. depth 35", length 52 – 53". Electrical: 115/60/1, not to exceed 12 AMPS. 1/2 or 3/4 HP condensing unit. Unit to be NSF and UL listed.

Warranty: Three year manufacturer's warranty on all parts and labor plus warranty against condensation build up, five year warranty on compressor must be included in the unit price. Set-up will include installation of shelves and clips and installation of wheels. Uncrate, set-in place, remove all cartons. Unit must be shipped with parts manual and schematics to each location.

Approved Brands: Victory Model FSA-2D-S1 or other brands meeting bid specifications

Brand Offered: _____

Model Offered: _____

Warranty Period: _____

Delivery (days ARO): _____

SECTION 6 - BID SPECIFICATIONS (CONTINUED)

In order to be considered for award, Bidders must fill these Bid Specifications Forms and the Electronic Bid Summary Sheet and submit them with their bid, in time for bid opening.

Item #

20 **SAP Number:** **6002185**

Item Name: **WARMER, DISPLAY**

Description: Adjustable display warmer with two-bulb reflectors and display base that accepts 12" x 20" steam table pans. Warmer to be 19-1/4" long x 13" wide x 28-1/4" high, with 6" wide bulb holder and 11-3/4" - 19-3/4" adjustable clearance between bottom of reflector and base. 120 volt, 500 watt with two 250W infrared bulbs included. Reflectors to be stainless steel, vented at the top, capable of holding one 250W bulb. On/off switch and six foot cord and plug included. To be delivered completely assembled. Manufacturer's standard warranty will apply.

Approved Brands: American Permanent Ware Model DW-1A, Nemco Model 6000A-2 or other brands meeting bid specifications

Brand Offered: _____

Model Offered: _____

Warranty Period: _____

Delivery (days ARO): _____

Item #

21 **SAP Number:** **6000020**

Item Name: **MERCHANDISER, GLASS DOOR**

Description: Factory engineered self-contained and energy efficient refrigeration system, – interior temperature holds 33 degrees F to 38 degrees F. If cap tube system, extra-large evaporator with higher horsepower compressor. Condensing unit positioned for easy maintenance. Self-lubricating evaporator fan motor(s) and larger fan blades for high volume air flow or equivalent to pull down warm product faster. Exterior to be non-peel or chip black or white laminated vinyl. Interior white aluminum with stainless steel floor. Entire cabinet insulated with foamed-in-place high density polyurethane insulation with zero ozone depletion potential. Door to have double pane thermal insulated glass with extruded alumina frame or equivalent. Positive seal closure with one piece magnetic door gasket without use of tools. LED lighting in interior w/ safety shield. To have four adjustable heavy-duty wire shelves with four clips per shelf. Approx. dimensions 27" w x 30" d x 78 5/8" h. Height not to exceed 80".

Pre-wired at factory and ready for final connection to a 115/60/1 phase, 15 amp dedicated outlet. Nema 5-15R cord and plug set included. Provide with factory installed lock.

Warranty: Three years manufacturer's warranty, all parts and labor with two extra years warranty on compressor. Price must include freight, inside delivery and complete operational setup.

Approved Brands: True Model GDM-23-HC-LD w/ optional barrel lock or other brands meeting bid specifications

Brand Offered: _____

Model Offered: _____

Warranty Period: _____

Delivery (days ARO): _____

SECTION 6 - BID SPECIFICATIONS (CONTINUED)

In order to be considered for award, Bidders must fill these Bid Specifications Forms and the Electronic Bid Summary Sheet and submit them with their bid, in time for bid opening.

ITEM 22 – TO BE AWARDED AS A GROUP

Item #

22 Item Name: SHELVING, ADJUSTABLE FOR WALK-IN COOLERS

Description: Removable open grid shelf mats are injection-molded polypropylene with built in Microban antimicrobial protection. With epoxy coated steel frames and posts. Weight Capacity for evenly distributed loads is 800 lbs. per shelf for lengths 36" to 48".
Individual shelf price to include: Inside delivery, uncrating, removal of packaging materials, four tier assembly and INSTALLATION REQUIRED inside walk-in cooler/freezer, and demonstration of features to Food Service managers. First shelf to be 6" AFF and remaining shelves to be spaced equally. Installation of shelves and posts included in bid price. Manufacturer's standard warranty will apply.

Approved Brands: InterMetro "MetroMaxQ", Amco Plastic Plus or other brands meeting bid specifications.

- 22A** SAP Number and Item Size: 6001239, **SHELF**, 18" Wide X 24" Long (QG)
- 22B** SAP Number and Item Size: 6001238, **SHELF**, 18" Wide X 30" Long (QG)
- 22C** SAP Number and Item Size: 6001234, **SHELF**, 18" Wide X 36" Long (QG)
- 22D** SAP Number and Item Size: 6000138, **SHELF**, 18" Wide X 42" Long (QG)
- 22E** SAP Number and Item Size: 6000139, **SHELF**, 18" Wide X 48" Long (QG)
- 22F** SAP Number and Item Size: 6001240, **SHELF**, 18" Wide X 54" Long (QG)
- 22G** SAP Number and Item Size: 6001236, **SHELF**, 18" Wide X 60" Long (QG)
- 22H** SAP Number and Item Size: 6001241, **SHELF**, 24" Wide X 24" Long (QG)
- 22I** SAP Number and Item Size: 6001242, **SHELF**, 24" Wide X 30" Long (QG)
- 22J** SAP Number and Item Size: 6001243, **SHELF**, 24" Wide X 36" Long (QG)
- 22K** SAP Number and Item Size: 6001244, **SHELF**, 24" Wide X 42" Long (QG)
- 22L** SAP Number and Item Size: 6001245, **SHELF**, 24" Wide X 48" Long (QG)
- 22M** SAP Number and Item Size: 6001246, **SHELF**, 24" Wide X 54" Long (QG)
- 22N** SAP Number and Item Size: 6001247, **SHELF**, 24" Wide X 60" Long (QG)
- 22O** SAP Number and Item Size: 6001237, **POST**, 63" or 64" High (QPE)
- 22P** SAP Number and Item Size: 6000140, **POST**, 72" or 74" High (QPE)

Brand Offered: _____

Warranty Period: _____

Delivery (days ARO): _____

SECTION 6 - BID SPECIFICATIONS (CONTINUED)

In order to be considered for award, Bidders must fill these Bid Specifications Forms and the Electronic Bid Summary Sheet and submit them with their bid, in time for bid opening.

ITEM 23 – TO BE AWARDED AS A GROUP

Item #

23A SAP Number: 6000071

Item Name: WARMER, COOKER – 7 QUART

Description: Seven Quart round cooker (crock pot) for heating soups. Type 430 stainless steel exterior, 24 gauge aluminum deep drawn well and heavy duty thermostat.

Element band heating for even distribution. 110-120V, minimum 500 watts with 3 prong grounded plug.

Unit price must include aluminum insert, lid and ladle.

Warranty: One year all parts and labor must be included in the unit price.

Approved Brand: Nemco Model 6102A-ICL, Vollrath Model 72018 ONLY

Brand Offered: _____

Model Offered: _____

Warranty Period: _____

Delivery (days ARO): _____

Item #

23B SAP Number: 6000072

Item Name: WARMER, COOKER – 11 QUART

Description: Eleven Quart round cooker (crock pot) for heating soups. Type 430 stainless steel exterior, 24 gauge aluminum deep drawn well and heavy duty thermostat.

Element band heating for even distribution. 110-120V, minimum 500 watts with 3 prong grounded plug.

Unit price must include aluminum insert, lid and ladle.

Warranty: One year all parts and labor must be included in the unit price.

Approved Brand: Nemco Model 6103-ICL, Vollrath Model 72009 ONLY

Brand Offered: _____

Model Offered: _____

Warranty Period: _____

Delivery (days ARO): _____

SECTION 6 - BID SPECIFICATIONS (CONTINUED)

In order to be considered for award, Bidders must fill these Bid Specifications Forms and the Electronic Bid Summary Sheet and submit them with their bid, in time for bid opening.

Item #

24 SAP Number: 6001076

Item Name: MERCHANDISER, REFRIGERATED VERTICAL OPEN

Description: Self-contained open front refrigeration system for self-serve salads and deli items designed for high humidity environment without a floor drain. Steel construction with baked enamel finish inside and out. Approx. dimensions 52" x 30" x 72". Four-position lighted cantilever shelves. Expansion valve system with heavy duty 1100 watt heated condensate pan, no drain required. CFC-free foamed-in-place urethane insulation. Timer controlled automatic defrost. Adjustable temperature controls. Minimum 3/4 HP compressor. Electrical: 115V/60 Hz/1 PH. Plus 208 V for condensate pan. Includes optional wrap around bumper and night cover. Color: White. Five years against insulation failure or leaks in insulated area and five years on compressor. Holds product at FDA required temperatures below 41° Fahrenheit. Provide with locking casters.
Factory installed Heated Condensate Pan. Connects to 15 amp., 208V outlet located inside cabinet.
Factory installed Night Cover.
Bid includes uncrate, set-in place, carton removal and installation of casters.

Warranty: Manufacturer's two year warranty in all parts and labor with five year parts/labor for compressor must be included in the unit price. Warranty on compressor to include shipping and pick up of old compressor upon phone call to factory.

Price must include inside delivery and complete operational setup.

Approved Brands: Hussman GSVM-5272 & Part #035S098 with heated condensate pan or True Model TAC-48-LD with heated condensate pan ONLY

Brand Offered: _____

Model Offered: _____

Warranty Period: _____
Delivery
(days ARO): _____

SECTION 6 - BID SPECIFICATIONS (CONTINUED)

In order to be considered for award, Bidders must fill these Bid Specifications Forms and the Electronic Bid Summary Sheet and submit them with their bid, in time for bid opening.

Item #

25 SAP Number: 6002186

Item Name: DRAWER, WARMER

Description: Exterior of drawer made of 20 gauge non-magnetic (corrosion resistant) stainless steel with (1) set of removable 16 gauge stainless drawer rail supports per drawer. Each cabinet is controlled by (1) On/Off adjustable thermostat with a range of 60° to 200°F and includes one holding temperature gauge to monitor inside air temperature. Analog temperature control. Each drawer includes (1) 12" x 20" x 6" stainless steel pan. The drawer assembly is easily adapted to accept an oversized 15" x 20" x 5" pan for greater capacity.

Electrical: 120V/60 Hz/1 PH, 5 – 10 amps, 600 to 1200 Watts.

Installed cord/cap: Nema 5-15P. Exterior size: 24-3/8"W x 24-5/8"L x 26-1/8"H.

Warranty: Two manufacturer's year warranty all parts and labor to be included in unit price. Bid price to include uncrate, set-in place and removal of cartons.

Approved Brands: Alto Shaam Model 500-2D ONLY

Brand Offered: _____

Model Offered: _____

Warranty Period: _____

Delivery (days ARO): _____

SECTION 6 - BID SPECIFICATIONS (CONTINUED)

In order to be considered for award, Bidders must fill these Bid Specifications Forms and the Electronic Bid Summary Sheet and submit them with their bid, in time for bid opening.

ITEM 26 – TO BE AWARDED AS A GROUP

Item #

26A SAP Number: 6000122

Item Name: OVEN, DOUBLE CONVECTION – STACK, GAS FIRED (LP/NATURAL)

Description: Unit to consist of two oven sections stacked operating separately and independently Stainless steel front, top, and sides. Doors shall be of triple-mounted pressure lock door design with turnbuckle assembly, solid stainless steel with dual pane thermal glass windows with single powder coated cool to touch handle that opens doors simultaneously. Oven interior to have a removable crum tray in each compartment. Oven to have five year limited warranty on doors. Oven baking compartments shall be of 16-gauge double-sided porcelain inside and out with coved corners. Unit to have 6' adjustable stainless steel legs with all fastening devices stainless steel. Oven to be constructed with fully welded angle iron frame. Shall have a stainless-steel combustion chamber, ball bearing slide out front control panel and interior halogen lights. Each section to be furnished with six chrome plated steel, heavy wire removable racks. Door, when opened, will automatically cut off fan. Also, to have switch to operate blower with door open for quick cool-down. Unit to have 60-minute batch timer, or solid state digital controls with cook & hold and fan pulse button and digital timer. Should include oven light switch and 'oven ready' indicator light. To be supplied with solid state manual control with two speed fan. Insulated with 1" solid block plus 1" mineral fiber insulation for a total of 2" of insulation. Main burner(s) ignition shall be achieved by a pilot burner operating through an electronic proven pilot spark ignition control system. Each section to have easily removable inshot burners with a rated total input minimum of 45,000 BTU's and shall have a 3/4 h.p. blower motor with thermal overload protection. Porcelain enameled modular control panel shall be supplied with a manual gas service cut-off switch located on the front of the control panel. Controls and fan motor to operate on 115V AC single phase, 8 amps. Oven to be Energy Star qualified.

All units National Sanitation Foundation (NSF) approved. Service manual, parts list and wiring diagrams must accompany each unit.

Warranty: Three year manufacturer's warranty all parts and two year labor must be included in the unit price.

Unit Price must include installation, service manuals, schematic diagrams and on-site demonstration for each delivered unit.

Approved Brand: Blodgett Model DFG-100-ES ONLY

Brand Offered: _____

Model Offered: _____

Warranty Period: _____

Delivery (days ARO): _____

SECTION 6 - BID SPECIFICATIONS (CONTINUED)

In order to be considered for award, Bidders must fill these Bid Specifications Forms and the Electronic Bid Summary Sheet and submit them with their bid, in time for bid opening.

ITEM 26 – TO BE AWARDED AS A GROUP - CONTINUED

Item #

26B SAP Number: 6001224

Item Name: OVEN, CONVECTION – SINGLE SECTION, GAS FIRED – NATURAL OR LP

Description: Single unit with dependent (simultaneous) doors. Stainless steel front, top, and sides. Doors shall be of triple-mounted pressure lock door design with turnbuckle assembly, solid stainless steel with dual pane thermal glass windows with single powder coated cool to touch handle that opens doors simultaneously. Oven interior to have a removable crum tray in each compartment. Oven to have five year warranty on complete door assembly. To be furnished with six chrome plated steel wire removable racks. Unit shall have ball bearing slide out front control panel and interior halogen lights. Oven liner shall be double sided porcelain enameled steel inside and out with coved corners. Doors, when open, will automatically cut off fan. Also to have switch to operate blower with door open for quick cool-down. Units to have 60 minute batch timer or solid state digital controls with fan plus button and digital timer. To be supplied with solid state manual control with two speed fan. Insulated with 1" solid block plus 1" mineral fiber insulation for 2" total insulation. Main burner ignition shall be achieved by a pilot burner operating through an electronic proven pilot spark ignition control system. Each section shall have two easily removable inshot burners with a rotated total input minimum of 45,000 BTU's. Two speed 1/2 - 3/4 h.p. motor with thermal overload protection. Porcelain enameled modular control panel shall be supplied with a manual gas service cut-off switch location on the front of control panel. Controls and fan motor to operate on 115V, AC single phase. Oven to be Energy Star Qualified.

All units to be Canadian Standards Association (CSA) and National Sanitation Foundation (NSF) approved.

Minimum interior dimensions: 27" w x 27 1/8" d x 29 1/4" h.

Warranty: Three year manufacturer's warranty, all parts and labor must be included in the unit price.

Unit Price must include inside delivery, set in place, level, remove packing materials, service manuals, schematic diagrams, factory start up, and on-site demonstration.

Approved Brands: Blodgett Model DFG-100-ES ONLY

Brand Offered: _____

Model Offered: _____

Warranty Period: _____

Delivery (days ARO): _____

SECTION 6 - BID SPECIFICATIONS (CONTINUED)

In order to be considered for award, Bidders must fill these Bid Specifications Forms and the Electronic Bid Summary Sheet and submit them with their bid, in time for bid opening.

ITEM 27 – TO BE AWARDED AS A GROUP

Item #

27A SAP Number: 6000123

Item Name: OVEN, CONVECTION – SINGLE SECTION, ELECTRIC FIRED

Description: Single unit with dependent simultaneous doors. Stainless steel front, sides, and top. Doors shall be of triple-mounted pressure lock door design with turnbuckle assembly, solid stainless steel with dual pane thermal glass windows with single powder coated cool to touch handle that opens doors simultaneously. 25" Adjustable legs and all fastening devices to be stainless steel. Dual pane thermal windows encased in stainless steel door frame. Oven baking compartments shall be of 16-gauge double-sided porcelain inside and out with coved corners. Shall have a ball bearing slide out front control panel and interior halogen lights. 5 Year limited door warranty. Doors, when open, will automatically cut off fan. Also to have switch to operate blower with door open for quick cool-down. Fully welded angle iron frame construction. Units to have 60 minute batch timer or solid state digital controls with cook & hold and fan pulse button and digital timer. To be supplied with solid state manual control with two speed fan. Insulated with solid block plus 1" mineral fiber insulation for a total of 2" of insulation. Each section to be furnished with six chrome plated steel, heavy wire removable racks and crumb tray. Standard depth baking compartment that accepts five (5) 18' x 26' sheet pans in left to right positions. Each section shall have three tubular heaters, one or three with a combined heater rating of 11.0 KWH. Electric 208V. Single or three phase. Air in baking chamber distributed by inlet blower wheel powered by a two speed, ½ - ¾" h.p. motor with thermal overload protection. Nominal amperes per line not to exceed 32 to fit on existing 40 amp breaker. Controls and fan motor to operate on 115V, AC single phase. Oven to be Energy Star Qualified.

All units to be Underwriter's Laboratories (UL) approved and National Sanitation Foundation (NSF) approved.

Warranty: Three year manufacturer's warranty all parts and labor must be included in the unit price. Unit Price must include uncrate, set in place & level, remove plastic, provide service manuals, schematic diagrams and on-site demonstration for each delivered unit.

Approved Brand: Blodgett Model Mark V-100 ONLY

Brand Offered: _____

Model Offered: _____

Warranty Period: _____

Delivery (days ARO): _____

SECTION 6 - BID SPECIFICATIONS (CONTINUED)

In order to be considered for award, Bidders must fill these Bid Specifications Forms and the Electronic Bid Summary Sheet and submit them with their bid, in time for bid opening.

ITEM 27 – TO BE AWARDED AS A GROUP - CONTINUED

Item #

27B SAP Number: 6001221
Item Name: OVEN, CONVECTION – SINGLE SECTION, ELECTRIC FIRED 480V
Description: Same as Item 27A, except 480Volt, three phase.

Approved Brand: Blodgett Model Mark V ONLY

Brand Offered: _____

Model Offered: _____

Warranty Period: _____

**Delivery
(days ARO):** _____

SECTION 6 - BID SPECIFICATIONS (CONTINUED)

In order to be considered for award, Bidders must fill these Bid Specifications Forms and the Electronic Bid Summary Sheet and submit them with their bid, in time for bid opening.

ITEM 27 – TO BE AWARDED AS A GROUP - CONTINUED

Item #

27C SAP Number: 6001222

Item Name: OVEN, CONVECTION DOUBLE STACK - ELECTRIC

Description: Electric, 208V, three phase, 12 K.W. unit to consist of two oven sections stacked operating separately and independently. Stainless steel front, sides, and top. 5 Year limited door warranty. Doors shall be of triple-mounted pressure lock door design with turnbuckle assembly, solid stainless steel with dual pane thermal glass windows with single powder coated cool to touch handle that opens doors simultaneously. Oven baking compartments shall be of 16-gauge double-sided porcelain inside and out with coved corners. Unit to have 6" adjustable stainless steel legs with all fastening devices to be stainless steel. Oven to be constructed with fully welded angle iron frame. Shall have a stainless-steel combustion chamber, ball bearing slide out front control panel and interior halogen lights. Each section to be furnished with six chrome plated steel, heavy wire removable racks and crumb tray. Standard depth baking compartment that accepts five (5) 18" x 26" sheet pans in left to right positions. Door, when opened, will automatically cut off fan. To be supplied with solid state manual control with two speed fan. Each section shall be equipped with three tubular heaters one or three phase with a combined heater rating of 10 KWH control area cooling fan Unit to have 60 minute batch timer, or solid state digital controls with fan plus button and digital timer. Insulated with 1" solid block plus 1" mineral fiber insulation for 2" total insulation. To have 1/2 – 3/4 h.p., 2 speed motor with thermal overload protection. Nominal amperes per line not to exceed 32 to fit on existing 40 amp breaker. Oven to be Energy Star Qualified.

All units to be National Sanitation Foundation (NSF) and Underwriter's Laboratories (UL) approved.

Unit Price must include uncrate, set in place & level, remove plastic, provide service manuals, schematic diagrams and on-site demonstration for each delivered unit.

Warranty: Three year manufacturer's warranty, all parts and labor must be included in the unit price.

Approved Brand: Blodgett Model Mark V-100 ONLY

Brand Offered: _____

Model Offered: _____

Warranty Period: _____

Delivery (days ARO): _____

SECTION 6 - BID SPECIFICATIONS (CONTINUED)

In order to be considered for award, Bidders must fill these Bid Specifications Forms and the Electronic Bid Summary Sheet and submit them with their bid, in time for bid opening.

ITEM 27 – TO BE AWARDED AS A GROUP - CONTINUED

Item #

27D SAP Number: 6001223
Item Name: OVEN, CONVECTION DOUBLE STACK – ELECTRIC 480V
Description: Same as Item 27C, except 480Volt, three phase.

Approved Brand: Blodgett Model Mark V-100 ONLY

Brand Offered: _____

Model Offered: _____

Warranty Period: _____
Delivery (days ARO): _____

Item #

27E SAP Number: 6000131
Item Name: BOILERLESS ONE-COMPARTMENT STEAMER
Description: Steamer cavity to be constructed of reinforced 14 gauge 304 stainless steel. Stainless steel support. Stand with flanged feet. No moving parts inside cooking chamber. Stem to be produced inside. Cooking cavity with no heating element exposed to water. Easily connects to water and drain Line. Unit to include low water, high water, overtemp warning lights and auto shut off feature. No water filtration or treatment required. No scheduled de-liming or maintenance. Holds 6 each full size 12 x 20 x 4" steamtable pans. Standard digital or manual controls with independent timer. 3/4" water connection in back of unit for automatic water fill. Water drain in front. U.L. and NSF approved. Energy Star qualified. AMP draw not to exceed 42.0 at 208v, 3 phase. Left hand hinge doors.

Bid price to include stainless steel stand with pan slides and installation of steamer on stand, leveling of unit.

Warranty: Two year warranty, all parts and labor must be included in the unit price.

Approved Brand: Accutemp E62083E150SGL ONLY

Brand Offered: _____

Model Offered: _____

Warranty Period: _____
Delivery (days ARO): _____

SECTION 6 - BID SPECIFICATIONS (CONTINUED)

In order to be considered for award, Bidders must fill these Bid Specifications Forms and the Electronic Bid Summary Sheet and submit them with their bid, in time for bid opening.

ITEM 27 – TO BE AWARDED AS A GROUP - CONTINUED

Item #

27F SAP Number: 6000134

**Item Name: CONVECTION STEAMER, TWO COMPARTMENT ELECTRIC STEAM GENERATOR.
6 PAN CAPACITY**

Description: Stainless steel pressure-less steamer with two twin atmospheric electric independent. Steam generators rated at a minimum of 9.0 KW each complete with electric low water cut-off. Heat up time to be minimum of ten minutes or less from a cold start. Unit shall allow operator to delime both steam generators through access port in each cavity without tools or service call from service agency.
Cavities and cabinet base stainless steel construction. Doors to be stainless steel, insulated, and provided with one-piece replaceable seal. Doors to have hidden magnetic door switch cutting power to blower and reducing power to generator when door is opened. 60 minute mechanical timer. Unit to include "Ready" or equivalent indicator light. Complete with automatic blow down when unit is turned off. Capacity for six 12" x 20" x 2-1/2" deep pans. Four stainless steel legs with level adjustment. Controls easily accessible from front or sides. Dual cold water connection provided so that steam generator is on a separate line from condenser.
National Sanitation Foundation (NSF) and Underwriter's Laboratories (UL) approved

Note to installers:

Plumbing requirements: Unit requires two 3/4" or 3/8" IPS cold water supply lines, 1-1/2" O.D. free venting drain. A second cold water connection is also provided for spray condenser.

Filter: Complete with Everpure Filter Model EV9797-22 Kleen Steam II Twin Filter System. Provide 2 ea. 4FC5 (EV9693-21) filters installed in system in lieu of 2 each EV9618-16 that comes standard with the system.

Electrical requirements: Unit requires 208V, single phase three wire or three phase. Unit must fit on existing 60 amp breaker in schools.

Warranty: Two year warranty, all parts and labor must be included in the unit price. Unit price must include uncrating, set-in place, Remove cartons, level, factory start up. Service manuals, parts lists and wiring diagrams must accompany each delivered unit.

Approved Brands: Groen Hyper Steam Model HY-6E ONLY

Brand Offered: _____

Model Offered: _____

Warranty Period: _____
Delivery
(days ARO): _____

SECTION 6 - BID SPECIFICATIONS (CONTINUED)

In order to be considered for award, Bidders must fill these Bid Specifications Forms and the Electronic Bid Summary Sheet and submit them with their bid, in time for bid opening.

ITEM 27 – TO BE AWARDED AS A GROUP - CONTINUED

Item #

27G SAP Number: 6000135

Item Name: STEAMER, CONVECTION, TWO COMPARTMENT – GAS FIRED, NATURAL OR LP

Description: Stainless steel pressure-less steamer with two twin atmospheric independent gas steam generators rated at a minimum of 35,000 BTU's each at 75% efficiency or minimum of 45,000 BTU's at 65% efficiency. Standing pilot light with electronic spark ignition. Heat up time shall be a minimum of ten minutes from a cold start. Unit to have low water cut-off. Unit shall allow operator to de-lime both steam generators through access port in each cavity without tools or service call from service agency. Cavities and cabinet base minimum 18 gauge 304 S/S stainless steel construction. Doors to be stainless steel, insulated, and provided with one-piece replaceable seal or gasket. Door to have hidden magnetic door switch cutting power to blower and reducing power to generator when door is opened. Unit to include "Ready" or equivalent indicator light. 60 minute mechanical timer. Complete with automatic blow down when unit is turned off. Capacity for six 12" x 20" x 2-1/2" deep pans. Four stainless steel legs with level adjustment. Controls easily accessible by pullout drawer or lift-off panel. Dual cold water connection necessary so that steam generators are on a separate line from condenser. NSF or CSA approved.

UNIT REQUIRES TWO 3/4" OR 3/8" IPS COLD WATER SUPPLY LINES, 1-1/2" OD FREE VENTING AND ELECTRIC SERVICE NOT TO EXCEED 115 V., SINGLE PHASE, 4 AMP. FILTER: Complete with Everpure Filter Model EV9797-22 Kleen Steam II Twin Filter System. Provide 2 ea. 4FC5 (EV9693-21) filters installed in system in lieu of 2 each EV9618-16 that comes standard with the system.

GAS REQUIREMENTS: UNIT REQUIRES NATURAL OR LP VIA 1/2" NPT PIPE OR APPROVED EQUIVALENT. UNIT REQUIRES 115V, SINGLE PHASE, FOUR AMP ELECTRIC SERVICE.

Warranty: Two manufacturer's year warranty, all parts and labor must be included in the unit price.

Unit price must include uncrating, set-in place, level unit and factory start-up. Service manuals, parts lists and wiring diagrams must accompany each delivered unit.

Approved Brand: Groen Hyper Steam Model HY-6G ONLY

Brand Offered: _____

Model Offered: _____

Warranty Period: _____

Delivery (days ARO): _____

SECTION 6 - BID SPECIFICATIONS (CONTINUED)

In order to be considered for award, Bidders must fill these Bid Specifications Forms and the Electronic Bid Summary Sheet and submit them with their bid, in time for bid opening.

ITEM 28 – TO BE AWARDED AS A GROUP

Item #

28A SAP Number: 6000097

Item Name: CART, FOOD – OUTDOOR, SECONDARY

Description: 74-1/4" long x 31-3/4" wide x 94" high, weight 240 pounds. Polyethylene with two insulated compartments below for storage and three four open compartments above to hold 4 full size pans 6" deep. To include cash drawer, removable umbrella 72" diameter, and a display panel to display menu. Work counter height is 36" with a see-through panel in front to help merchandise food. Casters are 8", four swivel and four brakes. Unit must be able to roll easily over concrete sidewalks. Manufacturer's standard warranty will apply.

Colors: Black, red, green, or gray.

Price must include inside delivery and complete operational setup.

Approved Brand: Cambro "Camcruiser" Model CVC724 or other brands meeting bid specifications

Brand Offered: _____

Model Offered: _____

Rack Offered: _____

Warranty Period: _____
Delivery
(days ARO): _____

Item #

28B SAP Number: 6000098

Item Name: STAND, CASHIER FOR OUTDOOR FOOD CART

Description: 27-3/4"wide x 27-3/4"deep x 39" high, with five inch heavy duty casters (two fixed and two swivel with brakes), seamless one-piece polyethylene construction to include right and left tray rail. Manufacturer's standard warranty will apply.

Color: Black.

Price must include inside delivery and complete operational setup.

Approved Brands: Cambro Model ES28RL or other brands meeting bid specifications

Brand Offered: _____

Model Offered: _____

Rack Offered: _____

Warranty Period: _____
Delivery
(days ARO): _____

SECTION 6 - BID SPECIFICATIONS (CONTINUED)

In order to be considered for award, Bidders must fill these Bid Specifications Forms and the Electronic Bid Summary Sheet and submit them with their bid, in time for bid opening.

ITEM 28 – TO BE AWARDED AS A GROUP - CONTINUED

Item #

28C SAP Number: 6000114

Item Name: CAMCART FOR FOOD PAN – CAPACITY 12 OR 16 PANS

Description: Enclosed seamless, one-piece, double-wall insulated cart. Polyethylene exterior. Polyurethane foam insulation. Heavy-duty design with two separate cavities for cold and hot foods. Recessed corrosion-free stainless steel hardware with rubber gasket for air tight closing to seal in heat. 5" - 6" diameter casters. Exterior dimensions with casters to be approximately 28-1/2" W x 32-1/4" D x 45-1/2" H. Capacity for 12 each 12-3/4" x 20-7/8" x 4" deep or 16 each 12-3/4" x 20-7/8" x 2-1/2" deep food pans. Manufacturer's standard warranty will apply.

Approved Brand: Cambro Model UPC1200 or other brands meeting bid specifications

Brand Offered: _____

Model Offered: _____

Warranty Period: _____
Delivery (days ARO): _____

Item #

28D SAP Number: 6000115

Item Name: CAMCART FOR FOOD PAN – CAPACITY 13 PANS

Description: Enclosed seamless, one-piece, double-wall insulated cart. Polyethylene exterior. Polyurethane foam insulation. Heavy-duty design with one compartment. Recessed corrosion-free stainless steel hardware with rubber gasket for air tight closing to seal in heat. 5" - 6" diameter casters. Exterior dimensions to be approximately 32" L x 21-1/2" W x 37-1/2" H. Capacity for 13 each 18" x 26" sheet pans. 13 Tray supports on 1-3/4" centers. Manufacturer's standard warranty will apply.

Approved Brand: Cambro Model 1826LTC or other brands meeting bid specifications

Brand Offered: _____

Model Offered: _____

Warranty Period: _____
Delivery (days ARO): _____

SECTION 6 - BID SPECIFICATIONS (CONTINUED)

In order to be considered for award, Bidders must fill these Bid Specifications Forms and the Electronic Bid Summary Sheet and submit them with their bid, in time for bid opening.

ITEM 28 – TO BE AWARDED AS A GROUP- CONTINUED

Item #

28E SAP Number: 6006233

Item Name: CART, CAMKIOSK, WITH UMBRELLA

Description: 85 1/8" long X 33-1/2" wide x 70 1/2" high, Polyethylene exterior with foam insulation that will not crack, chip, bubble, or break. Two insulated food storage cabinets to maintain hot food hot, cold food cold. Insulated compartments below for storage and four pan wells at top with work space. To include removable umbrella 72" diameter, lockable cash drawer, and menu display. Work counter height is 36". Casters are 6", two swivel, and two with brakes. Unit must be able to roll easily over concrete sidewalks. Manufacturer's standard warranty will apply.

Standard colors: Green, black, gray or equivalent. Accessories to include 2 each 1/2 size camchillers. Cambro model CP1210 or Equivalent and 1 each well cover. Cambro model WCR120.

Price must include inside delivery and complete operational setup.

Approved Brand: Cambro "Camkiosk" Model KVC854C or other brands meeting bid specifications

Brand Offered: _____

Model Offered: _____

Warranty Period: _____
Delivery (days ARO): _____

Item #

28F SAP Number: 6001149

Item Name: CAMCART FOR FOOD PAN – CAPACITY 6 OR 8 PANS

Description: Enclosed seamless, one-piece, double-wall insulated cart. Polyethylene exterior. Polyurethane foam insulation. Heavy-duty design with two separate cavities for cold and hot foods. Recessed corrosion-free stainless steel hardware with rubber gasket for air tight closing to seal in heat. 5" - 6" diameter casters. Exterior dimensions with casters to be approximately 20-1/2" W x 27-1/8" D x 45" H. Capacity for 6 each 12-3/4" x 20-7/8" x 4" deep or 8 each 12-3/4" x 20-7/8" x 2-1/2" deep food pans.

Manufacturer's standard warranty will apply.

Approved Brands: Cambro Model UPC600 or other brands meeting bid specifications

Brand Offered: _____

Model Offered: _____

Warranty Period: _____
Delivery (days ARO): _____

SECTION 6 - BID SPECIFICATIONS (CONTINUED)

In order to be considered for award, Bidders must fill these Bid Specifications Forms and the Electronic Bid Summary Sheet and submit them with their bid, in time for bid opening.

ITEM 28 – TO BE AWARDED AS A GROUP - CONTINUED

Item #

28G SAP Number: 6000091

Item Name: CAMCART FOR FOOD PAN – CAPACITY 16 OR 24 PANS

Description: Enclosed seamless, one-piece, double-wall insulated cart. Polyethylene exterior. Polyurethane foam insulation. Heavy-duty design with two separate cavities for cold and hot foods. Recessed corrosion-free stainless steel hardware with rubber gasket for air tight closing to seal in heat. 5" - 6" diameter casters. Exterior dimensions with casters to be approximately 28-1/8" W x 32-1/4" D x 54" H. Capacity for 16 pans 12-3/4" x 20-7/8" x 4" deep or 24 pans 12-3/4" x 20-7/8" x 2-1/2" deep food pans.

Manufacturer's standard warranty will apply.

Approved Brand: Cambro Model UPC1600 or other brands meeting bid specifications

Brand Offered: _____

Model Offered: _____

Warranty Period: _____
Delivery (days ARO): _____

Item #

28H SAP Number: 6000120

Item Name: CADDIE, ICE WITH SLIDING LID (TALL)

Description: Polyethylene construction body with thick foam insulation to provide long lasting ice storage and easily transportable. Approximate exterior dimensions 23" x 34" x 37 -1/2" with storage capacity of 175 lbs. of ice. Recessed well and drain shelf and recessed handle for easy moving. No assembly required. Two swivel casters, one brake and two rear easy wheels 8" – 10".

Manufacturer's standard warranty will apply. Colors: Black, blue, gray and green.

Approved Brand: Cambro Model ICS175TB or other brands meeting bid specifications

Brand Offered: _____

Model Offered: _____

Warranty Period: _____
Delivery (days ARO): _____

SECTION 6 - BID SPECIFICATIONS (CONTINUED)

In order to be considered for award, Bidders must fill these Bid Specifications Forms and the Electronic Bid Summary Sheet and submit them with their bid, in time for bid opening.

ITEM 28 – TO BE AWARDED AS A GROUP - CONTINUED

Item #

28 I SAP Number: 6001219

Item Name: CABINET, HOT BULK FOOD HOLDING/TRANSPORT-LOW PROFILE

Description: Plastic-based thermoelectric cart designed for holding and transporting food outdoors. Holds hot food temperatures for minimum of two hours. Thermoelectric unit located on back of unit must be completely enclosed. Air temperature inside cabinet must hold at an even range of 150 – 165° Fahrenheit. 6' long cord with wrapping hook. Control panel has polycarbonate waterproof cover, on/off switch and temperature dial. Double wall polyethylene external construction will not dent, crack, bubble or rust. Aluminum louvers in back wall of cavity direct air flow for even heat. Six universal chrome plated tray rails. Capacity of 12 each 12" x 20" x 2-1/2" deep. Approximate dimensions 30" x 42" x 43" high. Includes two each 6" front swivel with brake casters and two 10" rear rigid casters. 110 v., max. amp. Draw 10, Nema 5-15P plug.

Warranty: Two year manufacturer's warranty, all parts and labor must be included in the unit price.

Price must include inside delivery and complete operational setup.

Approved Brand: Cambro Model CMBH1826LF or other brands meeting bid specifications

Brand Offered: _____

Model Offered: _____

Warranty Period: _____

Delivery (days ARO): _____

SECTION 6 - BID SPECIFICATIONS (CONTINUED)

In order to be considered for award, Bidders must fill these Bid Specifications Forms and the Electronic Bid Summary Sheet and submit them with their bid, in time for bid opening.

ITEM 28 – TO BE AWARDED AS A GROUP CONTINUED

Item #

28J SAP Number: 6001220

Item Name: CABINET, HOT/COLD BULK FOOD HOLDING/TRANSPORT – LOW PROFILE

Description: Plastic-based thermoelectric cart designed for holding and transporting food outdoors. Holds hot food temperatures for minimum of two hours. Thermoelectric unit located on back of unit and must be completely enclosed. Inside cabinet must hold at an even range of 150 -165° Fahrenheit. When cooled to 37°, internal cavity temperature must remain below 41° for a minimum of two hours. 6' long cord with wrapping hook. Control panel has polycarbonate waterproof cover, on/off switch and temperature dial. Double wall polyethylene external construction will not dent, crack, bubble or rust. Aluminum louvers in back wall of cavity direct air flow for even heat. Six universal chrome plated tray rails. Capacity of 12 each 12" x 20" x 2-1/2" deep. Approximate dimensions 30" x 42" x 43" high. Includes two each 6" front swivel with brake casters and two 10" rear rigid casters. 110 v., max. amp. draw 10, Nema 5-15P plug.

Warranty: Two year manufacturer's warranty, all parts and labor must be included in the unit price.

Price must include inside delivery and complete operational setup.

Approved Brand: CMBHC1826LF or other brands meeting bid specifications

Brand Offered: _____

Model Offered: _____

Warranty Period: _____

Delivery (days ARO): _____

SECTION 6 - BID SPECIFICATIONS (CONTINUED)

In order to be considered for award, Bidders must fill these Bid Specifications Forms and the Electronic Bid Summary Sheet and submit them with their bid, in time for bid opening.

ITEM 29 – TO BE AWARDED AS A GROUP

Item #

29A SAP Number: 6000085

Item Name: BAR, SALAD – FOUR PAN CAPACITY

Description: Mobile insulated self service food bar polyethylene seamless construction, complete unit to be insulated with polyurethane foam. Four full size pan capacity. Storage cabinet with sliding doors below. Casters to be five inch diameter, swivel with brakes including base plate for fastening N.S.F. approved, one piece full-length sneeze guard. Exterior dimensions: 63-1/2" long x 33-1/4" wide x 52-1/2" high. Interior well dimensions: 50-1/16" long x 20-1/8" wide x 6-1/2" deep. Floor to top of well 34-1/2". Top of well to bottom of sneeze guard 10-7/8". Manufacturer's standard warranty will apply.

Approved Brand: Cambro "Food Bar" Model VBR5 or other brands meeting bid specifications

Brand Offered: _____

Model Offered: _____

Warranty Period: _____
Delivery (days ARO): _____

Item #

29B SAP Number: 6000086

Item Name: BAR, SALAD – FIVE PAN CAPACITY

Description: Mobile insulated self service food bar polyethylene seamless construction, complete unit to be insulated with polyurethane foam. Storage cabinet with sliding doors below. Casters to be five inch diameter, swivel with brakes including base plate for fastening N.S.F. approved, one piece full-length sneeze guard. Exterior dimensions: 71-1/2" long x 32-3/4" wide x 52-1/2" high. Interior well dimensions: 62-7/8" long x 20-1/8" wide x 6-1/2" deep. Floor to top of well 34-1/2". Top of well to bottom of sneeze guard 10-7/8". Manufacturer's standard warranty will apply.

Approved Brand: Cambro "Food Bar" Model VBR6 or other brands meeting bid specifications

Brand Offered: _____

Model Offered: _____

Warranty Period: _____
Delivery (days ARO): _____

SECTION 6 - BID SPECIFICATIONS (CONTINUED)

In order to be considered for award, Bidders must fill these Bid Specifications Forms and the Electronic Bid Summary Sheet and submit them with their bid, in time for bid opening.

ITEM 29 – TO BE AWARDED AS A GROUP - CONTINUED

Item #

29C **SAP Number:** **6000087**
Item Name: **BAR, SALAD – TABLE TOP**
Description: Mobile insulated self service food bar polyethylene seamless construction, complete unit to be insulated with polyurethane foam. Table top model. One piece full-length N.S.F. listed sneeze guard. To include drain plug. Manufacturer’s standard warranty will apply. Exterior dimensions: 51" long x 33-1/4" high x 27" deep.
Approved Brands: Cambro “Food Bar” Model 4FBRTT or other brands meeting bid specifications

Brand Offered: _____
Model Offered: _____
Warranty Period: _____
Delivery (days ARO): _____

Item #

29D **SAP Number:** **6002187**
Item Name: **RAIL, ACCESSORY FOR SALAD BAR – FIVE FEET**
Description: Made of durable lightweight polyethylene five foot long. Must match salad bars. Size: 63-1/2" L x 8" W x 1-1/2" D. Height from floor 34-3/4". Manufacturer’s standard warranty will apply.
Approved Brand: Cambro Model VBRR5 or other brands meeting bid specifications

Brand Offered: _____
Model Offered: _____
Warranty Period: _____
Delivery (days ARO): _____

Item #

29E **SAP Number:** **6002188**
Item Name: **RAIL, ACCESSORY FOR SALAD BAR – SIX FEET**
Description: Made of durable lightweight polyethylene five foot long. Must match salad bars. Size: 70" L x 8" W x 1-1/2" D. Height from floor 34-3/4". Manufacturer’s standard warranty will apply.
Approved Brand: Cambro Model VBRR6 or other brands meeting bid specifications

Brand Offered: _____
Model Offered: _____
Warranty Period: _____
Delivery (days ARO): _____

SECTION 6 - BID SPECIFICATIONS (CONTINUED)

In order to be considered for award, Bidders must fill these Bid Specifications Forms and the Electronic Bid Summary Sheet and submit them with their bid, in time for bid opening.

ITEM 29 – TO BE AWARDED AS A GROUP

Item #

29F SAP Number: 6006234

Item Name: VERSA CART W/DUAL TRAY RAILS

Description: 52-3/4" wide x 32" deep x 43-3/4" high, with five inch heavy duty casters (two fixed and two swivel with brakes), seamless one-piece polyethylene construction to include dual tray rails. Manufacturer's standard warranty will apply. Ergonomic molded-in handles for easy maneuvering. Sneeze guards and tray slides fold down to fit through a standard 3' door. At least four colors to choose from, tray rails must be available in same colors as cart. Inside delivery, full assembly, set in place required.

Approved Brands: Cambro Model VCSWRHD or other brands meeting bid specifications

Brand Offered: _____

Model Offered: _____

Warranty Period: _____
Delivery
(days ARO): _____

Item #

29G SAP Number: 6006235

Item Name: VERSA WORK TABLE – FIVE FEET

Description: Mobile insulated self-service food bar polyethylene seamless construction, complete unit to be insulated with polyurethane foam. Heavy duty casters to be five inch diameter, swivel with brakes including base plate for fastening. Ergonomic molded-in handles for easy maneuvering. Fits through a standard 3' door. Exterior dimensions: Approx. 69" long x 27" wide x 36-1/4" x 36-1/4" high. Interior well dimensions: Approx. 59-9/32" long x 21" wide x 7-1/8" deep. Top of well to bottom of sneeze guard approx. 10-7/8". Manufacturer's standard warranty will apply. Inside delivery, full assembly, set in place required. N.S.F. approved.

Approved Brand: Cambro Model VBRTHD5 or other brands meeting bid specifications

Brand Offered: _____

Model Offered: _____

Warranty Period: _____
Delivery
(days ARO): _____

SECTION 6 - BID SPECIFICATIONS (CONTINUED)

In order to be considered for award, Bidders must fill these Bid Specifications Forms and the Electronic Bid Summary Sheet and submit them with their bid, in time for bid opening.

GROUP ITEM 30 NOTES:

1. SERVING LINES MAY BE ORDERED IN ANY CONFIGURATION OF ITEMS INCLUDED IN GROUP 31.
2. AWARDED VENDOR IS NOT RESPONSIBLE FOR ELECTRICAL OR PLUMBING HOOK-UP.
3. FOR THIS GROUP OF ITEMS, BIDDER MUST OFFER ITEMS FROM THE SAME MANUFACTURER.
4. SEE SPECIAL CONDITION 13 – INSTALLATION. ALL MOLDED BODIES TO HAVE FIVE YEAR WARRANTY.

Item #

30A SAP Number: 6001143

Item Name: TABLE, ELECTRIC HOT FOOD SERVING, OPEN BASE – 50”

Description: Unit to have fiberglass reinforced polyester (F.R.P.) molded with permanent color or 18-8 type 304 stainless steel with smooth exterior surfaces and rounded corners. All fiberglass to be flame retardant per specification ASTM E-162. Body to be 50" long and 28" - 30" wide (top) and available in 34", 35", and 36" heights. Body constructed to accommodate tray rail at heights of 32", 33", and 34". (Bid does not include tray rail.) Body constructed with internal support member fabricated of a minimum of 14 gauge galvaneal channel to securely fasten tray rail support brackets. Provide with six inch stainless steel adjustable legs. Internal framing is to be 4-1/2" wide, galvaneal channel, shall be mounted vertically on front and bottom surfaces and across the interior bottom to form a "U" shaped channel frame. "U" frame mounted at leg attachment location. Internal framing "U" channel 3 1/2" – 4-1/2" wide on operators side. Exterior 20 gauge stainless steel channel mounted between bottom of fiberglass body and legs to provide maximum stress relief. **(See Section 6.1-ILLUSTRATIONS)**

Top shall be constructed of 14 gauge, Grade 18-8 stainless steel with a number four finish, welded, ground and polished. Top shall have three individual 12" x 20" die stamped openings for individual recessed electrically heated stainless steel hot food wells with three individual controls, each rated at 500 watts at 208 VAC. Wells pre-wired to a circuit breaker mounted in the control panel for overload protection. Dry/moist electric hot food wells to be bottom mounted and have 12" x 20" die stamped opening with 1/4" raised beaded edge. Provide access panel inside storage base for access to hot food wells from below counter top required. All hot food wells and elements need to be accessed without cutting hole in table. Each drain from hot well shall contain a union to facilitate ease of removal of hot wells. Drains to be 3/4" and pre-piped to a common manifold with a 1/4" turn ball valve as shut-off. Shut-off valve to be 6" from operator underneath unit. Full length open under storage constructed of 18 gauge stainless steel with coved vertical and horizontal corners. U.L. Listed for safety. U.L. Sanitation Certified or N.S.F. listed.
Electric: 208Volt, One or Three Phase.

Warranty: Two year manufacturer’s warranty, all parts and labor must be included in the unit price.

Approved Brand: Colorpoint Model 5E3CPA or Delfield Model KH-3-NU-MB or other brands meeting bid specifications

Brand Offered: _____

Model Offered: _____

Warranty Period: _____

Delivery (days ARO): _____

SECTION 6 - BID SPECIFICATIONS (CONTINUED)

In order to be considered for award, Bidders must fill these Bid Specifications Forms and the Electronic Bid Summary Sheet and submit them with their bid, in time for bid opening.

GROUP ITEM 30 NOTES:

1. SERVING LINES MAY BE ORDERED IN ANY CONFIGURATION OF ITEMS INCLUDED IN GROUP 31.
2. AWARDED VENDOR IS NOT RESPONSIBLE FOR ELECTRICAL OR PLUMBING HOOK-UP.
3. FOR THIS GROUP OF ITEMS, BIDDER MUST OFFER ITEMS FROM THE SAME MANUFACTURER.
4. SEE SPECIAL CONDITION 13 – INSTALLATION. ALL MOLDED BODIES TO HAVE FIVE YEAR WARRANTY.

SECTION 6 - BID SPECIFICATIONS (CONTINUED)

In order to be considered for award, Bidders must fill these Bid Specifications Forms and the Electronic Bid Summary Sheet and submit them with their bid, in time for bid opening.

GROUP ITEM 30 NOTES:

- 1. SERVING LINES MAY BE ORDERED IN ANY CONFIGURATION OF ITEMS INCLUDED IN GROUP 31.
- 2. AWARDED VENDOR IS NOT RESPONSIBLE FOR ELECTRICAL OR PLUMBING HOOK-UP.
- 3. FOR THIS GROUP OF ITEMS, BIDDER MUST OFFER ITEMS FROM THE SAME MANUFACTURER.
- 4. SEE SPECIAL CONDITION 13 – INSTALLATION. ALL MOLDED BODIES TO HAVE FIVE YEAR WARRANTY.

Item #

30B SAP Number: 6001114

Item Name: TABLE, ELECTRIC HOT FOOD SERVING, OPEN BASE – 60"

Description: Unit to have fiberglass reinforced polyester (F.P.R.) molded with permanent color or 18-8 type 304 stainless steel with smooth exterior surfaces and rounded corners. All fiberglass to be flame retardant per specification ASTM E-162. Body to be 60" long, 28" - 30" wide (top) and available in 34", 35", and 36" heights. Body constructed to accommodate tray rail at heights of 32", 33", and 34". (Bid does not include tray rail.) Body constructed with internal support member fabricated of a minimum of 14 gauge galvaneal channel to securely fasten tray rail support brackets. Provide with six inch stainless steel adjustable legs. Internal framing is to be 4-1/2" wide, galvaneal channel, shall be mounted vertically on front and rear surfaces and across the interior bottom to form a "U" shaped channel frame. "U" frame mounted at leg attachment location. "U" channel to be 3-1/2" – 4-1/2" wide on operators side. Exterior 20 gauge stainless steel channel mounted between bottom of fiberglass body and legs to provide maximum stress relief. **(See Section 6.1-ILLUSTRATIONS)**

Top shall be constructed of 14 gauge, Grade 18-8 stainless steel with a number four finish, welded, ground and polished. Top shall have four individual 12" x 20" die stamped openings for individual recessed electrically heated stainless steel hot food wells with drains and four individual controls, each rated at 500 watts at 208 VAC. Wells pre-wired to a circuit breaker mounted in the control panel for overload protection. Dry/moist electric hot food wells to be bottom mounted and have a 12" x 20" die stamped opening with 1/4" raised beaded edge. Provide access panel inside storage base for access to hot food wells from below counter top required. All hot food wells and elements need to be accessed without cutting hole in table. Each drain from hot well shall contain a union to facilitate ease of removal of hot wells. Drains to be 3/4" and prepiped to a common manifold with a 1/4" turn ball valve as shut-off. Shut-off valve to be six inch from operator underneath unit. Full length open under storage constructed of 18 gauge stainless steel with coved vertical and horizontal corners. U.L. Listed for safety. U.L. Sanitation Certified or N.S.F. listed.

Warranty: Two year manufacturer's warranty, all parts and labor must be included in the unit price.

Approved Brands: Colorpoint Model 5E4-CPA, Delfield KH-4-NU-MB or other brands meeting bid specifications

Brand Offered: _____

Model Offered: _____

Warranty Period: _____

Delivery (days ARO): _____

SECTION 6 - BID SPECIFICATIONS (CONTINUED)

In order to be considered for award, Bidders must fill these Bid Specifications Forms and the Electronic Bid Summary Sheet and submit them with their bid, in time for bid opening.

GROUP ITEM 30 NOTES:

1. SERVING LINES MAY BE ORDERED IN ANY CONFIGURATION OF ITEMS INCLUDED IN GROUP 31.
2. AWARDED VENDOR IS NOT RESPONSIBLE FOR ELECTRICAL OR PLUMBING HOOK-UP.
3. FOR THIS GROUP OF ITEMS, BIDDER MUST OFFER ITEMS FROM THE SAME MANUFACTURER.
4. SEE SPECIAL CONDITION 13 – INSTALLATION. ALL MOLDED BODIES TO HAVE FIVE YEAR WARRANTY.

Item #

30C SAP Number: 6000099

Item Name: TABLE, ELECTRIC HOT FOOD SERVING, OPEN BASE – 74”

Description: Unit to have fiberglass reinforced polyester (F.P.R.) molded with permanent color or 18-8 type 304 stainless steel with smooth exterior surfaces and rounded corners. All fiberglass to be flame retardant per specification ASTM E-162. Body to be 74" long and 30" wide (top) and available in 34", 35", and 36" heights. Body constructed to accommodate tray rail at heights of 32", 33", and 34". (Bid does not include tray rail.) Body constructed with internal support member fabricated of a minimum of 14 gauge galvaneal channel to securely fasten tray rail support brackets. Provide with six inch stainless steel adjustable legs. Internal framing is to be 4-1/2" wide, galvaneal channel, shall be mounted vertically on front and rear surfaces and across the interior bottom to form a "U" shaped channel frame. "U" frame mounted at leg attachment location. "U" channel to be 3-1/2" – 4-1/2" wide on operators side. Exterior 20 gauge stainless steel channel mounted between bottom of fiberglass body and legs to provide maximum stress relief. (See Section 6.1-ILLUSTRATIONS)

Top shall be constructed of 14 gauge, Grade 18-8 stainless steel with a number four finish, welded, ground and polished. Top shall have five individual 12" x 20" die stamped openings for individual recessed electrically heated stainless steel hot food wells with drains and five individual controls, each rated at 500 watts at 208 VAC. All wells pre-wired to a circuit breaker mounted in the control panel for overload protection. Dry/moist electric hot food wells to be bottom mounted and have a 12" x 20" die stamped opening with 1/4" raised beaded edge. Provide access panel inside storage base for access to hot food wells from below counter top required. All hot food wells and elements need to be accessed without cutting hole in table. Each drain from hot well shall contain a union to facilitate ease of removal of hot well. Drains to be 3/4" and prepiped to a common manifold with a 1/4" turn ball valve as shut-off. Shut-off valve to be six inch from operator underneath unit. Full length open under storage constructed of 18 gauge stainless steel with coved vertical and horizontal corners. U.L. Listed for safety. U.L. Sanitation Certified or N.S.F. listed.

Warranty: Two year manufacturer’s warranty, all parts and labor must be included in the unit price.

Approved Brands: Colorpoint Model 5E5-CPA, Delfield Model KH-5NU-MB or other brands meeting bid specifications

Brand Offered: _____

Model Offered: _____

Warranty Period: _____

Delivery (days ARO): _____

SECTION 6 - BID SPECIFICATIONS (CONTINUED)

In order to be considered for award, Bidders must fill these Bid Specifications Forms and the Electronic Bid Summary Sheet and submit them with their bid, in time for bid opening.

GROUP ITEM 30 NOTES:

1. SERVING LINES MAY BE ORDERED IN ANY CONFIGURATION OF ITEMS INCLUDED IN GROUP 31.
2. AWARDED VENDOR IS NOT RESPONSIBLE FOR ELECTRICAL OR PLUMBING HOOK-UP.
3. FOR THIS GROUP OF ITEMS, BIDDER MUST OFFER ITEMS FROM THE SAME MANUFACTURER.
4. SEE SPECIAL CONDITION 13 – INSTALLATION. ALL MOLDED BODIES TO HAVE FIVE YEAR WARRANTY.

Item #

30D SAP Number: 6006239

Item Name: TABLE, ELECTRIC HOT FOOD SERVING, OPEN BASE – 84”

Description: Unit to have fiberglass reinforced polyester (F.R.P.) molded with permanent color or 18-8 type 304 stainless steel with smooth exterior surfaces and rounded corners. All fiberglass to be flame retardant per specification ASTM E-162. Body to be 84" long and 28" - 30" wide (top) and available in 34", 35", and 36" heights. Body constructed to accommodate tray rail at heights of 32", 33", and 34". (Bid does not include tray rail.) Body constructed with internal support member fabricated of a minimum of 14 gauge galvaneal channel to securely fasten tray rail support brackets. Provide with six inch stainless steel adjustable legs. Internal framing is to be 4-1/2" wide, galvaneal channel, shall be mounted vertically on front and bottom surfaces and across the interior bottom to form a "U" shaped channel frame. "U" frame mounted at leg attachment location. Internal framing "U" channel 3 1/2" – 4-1/2" wide on operators side. Exterior 20 gauge stainless steel channel mounted between bottom of fiberglass body and legs to provide maximum stress relief. **(See Section 6.1-ILLUSTRATIONS)**

Top shall be constructed of 14 gauge, Grade 18-8 stainless steel with a number four finish, welded, ground and polished. Top shall have four individual 12" x 20" die stamped openings for individual recessed electrically heated stainless steel hot food wells with four individual controls, each rated at 900-1,000 watts at 208 VAC. Unit to have approximately 24" of flat top space with 30" heat strip centered over flat top area and one hot food well. This space is to serve pizza. Wells pre-wired to a circuit breaker mounted in the control panel for overload protection. Dry/moist electric hot food wells to be bottom mounted and have 12" x 20" die stamped opening with 1/4" raised beaded edge. Provide access panel inside storage base for access to hot food wells from below counter top required. All hot food wells and elements need to be accessed without cutting hole in table. Each drain from hot well shall contain a union to facilitate ease of removal of hot wells. Drains to be 3/4" and pre-piped to a common manifold with a 1/4" turn ball valve as shut-off. Shut-off valve to be 6" from operator underneath unit. Full length open under storage constructed of 18 gauge stainless steel with coved vertical and horizontal corners. U.L. Listed for safety. U.L. Sanitation Certified or N.S.F. listed. Electric: 208Volt, One or Three Phase.

Warranty: Two year manufacturer’s warranty, all parts and labor must be included in the unit price.

Approved Brand:
Colorpoint Model EF5-CPA-84-MOD or Delfield Model KH-5-NU-MB-MOD or other brands meeting bid specifications

Brand Offered: _____

Model Offered: _____

Warranty Period: _____

Delivery (days ARO): _____

SECTION 6 - BID SPECIFICATIONS (CONTINUED)

In order to be considered for award, Bidders must fill these Bid Specifications Forms and the Electronic Bid Summary Sheet and submit them with their bid, in time for bid opening.

GROUP ITEM 30 NOTES:

1. SERVING LINES MAY BE ORDERED IN ANY CONFIGURATION OF ITEMS INCLUDED IN GROUP 31.
2. AWARDED VENDOR IS NOT RESPONSIBLE FOR ELECTRICAL OR PLUMBING HOOK-UP.
3. FOR THIS GROUP OF ITEMS, BIDDER MUST OFFER ITEMS FROM THE SAME MANUFACTURER.
4. SEE SPECIAL CONDITION 13 – INSTALLATION. ALL MOLDED BODIES TO HAVE FIVE YEAR WARRANTY.

Item #

30E SAP Number: 6001117

Item Name: TABLE, ICE COOLED COLD – OPEN BASE – 30”

Description: Body to be seamless mold fiberglass with smooth exterior surfaces and rounded corners or 18-8 type 304 stainless steel with smooth exterior surfaces and rounded corners. All fiberglass to be flame retardant per specifications ASTM E-162. To be 28" - 30" wide x 30" long and available in 34", 35", and 36" heights. Body constructed to accommodate tray rail at heights of 32", 33", and 34". (Bid does not include tray rail.) Top to be fabricated from 14 gauge stainless steel with square turndown on all sides and corners fully welded, ground, and polished with #4 finish. Body constructed with internal support member fabricated of a minimum of 12 gauge galvaneal channel to securely fasten tray rail support brackets. Provide with six inch stainless steel adjustable legs. Internal framing is to be 4-1/2" wide, galvaneal channel, shall be mounted vertically on front and rear surfaces and across the interior bottom to form a "U" shaped channel frame. "U" frame mounted at leg attachment location. "U" channel to be 3-1/2" – 4-1/2" wide on operators side. Exterior 20 gauge stainless steel channel mounted between bottom of fiberglass body and legs to provide maximum stress relief. **(See Section 6.1-ILLUSTRATIONS)**

The ice cold pan to be 18 gauge stainless steel and six inch deep. Pan to be welded, watertight and fully insulated with urethane insulation and removable false bottom. To have full perimeter Formica breaker strip to separate the top from the cold pan. To have drain with extension to shut-off valve below base. Open under storage to be lined with 18 gauge stainless steel coved vertical and horizontal corners. With six inch stainless steel adjustable legs. Bid price to include adapter plate for 18" x 26" sheet pan. U.L. Listed and N.S.F.

Approved.

Warranty: Two year manufacturer’s warranty, all parts and labor must be included in the unit price.

Approved Brands:
Colorpoint Model 36-CFI Modified to 30” long, Delfield Model KCI-36-NU-MB or other brands meeting bid specifications

Brand Offered: _____

Model Offered: _____

Warranty Period: _____

Delivery (days ARO): _____

SECTION 6 - BID SPECIFICATIONS (CONTINUED)

In order to be considered for award, Bidders must fill these Bid Specifications Forms and the Electronic Bid Summary Sheet and submit them with their bid, in time for bid opening.

GROUP ITEM 30 NOTES:

1. SERVING LINES MAY BE ORDERED IN ANY CONFIGURATION OF ITEMS INCLUDED IN GROUP 31.
2. AWARDED VENDOR IS NOT RESPONSIBLE FOR ELECTRICAL OR PLUMBING HOOK-UP.
3. FOR THIS GROUP OF ITEMS, BIDDER MUST OFFER ITEMS FROM THE SAME MANUFACTURER.
4. SEE SPECIAL CONDITION 13 – INSTALLATION. ALL MOLDED BODIES TO HAVE FIVE YEAR WARRANTY.

Item #

30F SAP Number: 6001118

Item Name: TABLE, ICE COOLED COLD – OPEN BASE – 36”

Description: Body to be seamless mold fiberglass with smooth exterior surfaces and rounded corners or 18-8 type 304 stainless steel with smooth exterior surfaces and rounded corners. All fiberglass to be flame retardant per specifications ASTM E-162. To be 28" - 30" wide x 36" long and available in 34", 35", and 36" heights. Body constructed to accommodate tray rail at heights of 32", 33", and 34". (Bid does not include tray rail.) Top to be fabricated from 14 gauge stainless steel with square turndown on all sides and corners fully welded, ground, and polished with #4 finish. Cold pan to accommodate two 12" x 20" hotel pans or one 18" x 26" sheet pan. Body constructed with internal support members fabricated of a minimum of 12 gauge galvaneal channel to securely fasten tray rail support brackets. Provide with six inch stainless steel adjustable legs. Internal framing is to be 4-1/2" wide, galvaneal channel, shall be mounted vertically on front and rear surfaces and across the interior bottom to form a "U" shaped channel frame. "U" frame mounted at leg attachment location. "U" channel to be 3-1/2" – 4-1/2" wide on operators side. Exterior 20 gauge stainless steel channel mounted between bottom of fiberglass body and legs to provide maximum stress relief. **(See Section 6.1-ILLUSTRATIONS)**

The ice cold pan to be 18 gauge stainless steel and six inch deep. Pan to be welded, watertight and fully insulated with urethane insulation and removable false bottom. To have full perimeter Formica breaker strip to separate the top from the cold pan. To have drain with extension to shut-off valve below base. Open under storage to be lined with 18 gauge stainless steel **coved vertical and horizontal corners**. With six inch stainless steel adjustable legs. Bid price to include adapter plate for 18" x 26" sheet pan. U.L. Listed and N.S.F. Approved.

Warranty: Two year manufacturer’s warranty, all parts and labor must be included in the unit price.

Approved Brands: Colorpoint Model 36-CFI Modified, Delfield Model KCI-36-NU-MB or other brands meeting bid specifications

Brand Offered: _____

Model Offered: _____

Warranty Period: _____

Delivery (days ARO): _____

SECTION 6 - BID SPECIFICATIONS (CONTINUED)

In order to be considered for award, Bidders must fill these Bid Specifications Forms and the Electronic Bid Summary Sheet and submit them with their bid, in time for bid opening.

GROUP ITEM 30 NOTES:

1. SERVING LINES MAY BE ORDERED IN ANY CONFIGURATION OF ITEMS INCLUDED IN GROUP 31.
2. AWARDED VENDOR IS NOT RESPONSIBLE FOR ELECTRICAL OR PLUMBING HOOK-UP.
3. FOR THIS GROUP OF ITEMS, BIDDER MUST OFFER ITEMS FROM THE SAME MANUFACTURER.
4. SEE SPECIAL CONDITION 13 – INSTALLATION. ALL MOLDED BODIES TO HAVE FIVE YEAR WARRANTY.

Item #

30G SAP Number: 6000109

Item Name: TABLE, ICE COOLED COLD – OPEN BASE – 50-51”

Description: Body to be constructed of fiberglass panels with vertical and horizontal stainless steel trim or 18-8 type 304 stainless steel with smooth exterior surfaces and rounded corners. All fiberglass to be flame retardant per specifications ASTM E-162. To be 34" wide x 50" - 51" long and available in 34", 35", and 36" heights. Body constructed to accommodate tray rail at heights of 32", 33", and 34". (Bid does not include tray rail.) Top to be fabricated from 14 gauge stainless steel with square turndown on all sides and corners fully welded, ground, and polished with #4 finish. Body constructed with internal support member fabricated of a minimum of 12 gauge galvaneal channel to securely fasten tray rail support brackets. Provide with 6" stainless steel adjustable legs. Internal framing is to be 4-1/2" wide, galvaneal channel, shall be mounted vertically on front and rear surfaces and across the interior bottom to form a "U" shaped channel frame. "U" frame mounted at leg attachment location. "U" channel to be 3-1/2" – 4-1/2" wide on operators side. Exterior 20 gauge stainless steel channel mounted between bottom of fiberglass body and legs to provide maximum stress relief. **(See Section 6.1-ILLUSTRATIONS)**

The ice cold pan to be 18 gauge stainless steel and 6" deep. Pan to be welded, watertight and fully insulated with urethane insulation and removable false bottom. To have full perimeter Formica breaker strip to separate the top from the cold pan. To have drain with extension to shut-off valve below base. Open under storage to be lined with 18 gauge stainless steel **coved vertical and horizontal corners**. With 6" stainless steel adjustable legs. U.L. Listed and N.S.F. Approved.

Warranty: Two year manufacturer’s warranty, all parts and labor must be included in the unit price.

Approved Brands: Colorpoint Model 50-CFI, Delfield Model KCI-50-NU-MB or other brands meeting bid specifications

Brand Offered: _____

Model Offered: _____

Warranty Period: _____

Delivery (days ARO): _____

SECTION 6 - BID SPECIFICATIONS (CONTINUED)

In order to be considered for award, Bidders must fill these Bid Specifications Forms and the Electronic Bid Summary Sheet and submit them with their bid, in time for bid opening.

GROUP ITEM 30 NOTES:

1. SERVING LINES MAY BE ORDERED IN ANY CONFIGURATION OF ITEMS INCLUDED IN GROUP 31.
2. AWARDED VENDOR IS NOT RESPONSIBLE FOR ELECTRICAL OR PLUMBING HOOK-UP.
3. FOR THIS GROUP OF ITEMS, BIDDER MUST OFFER ITEMS FROM THE SAME MANUFACTURER.
4. SEE SPECIAL CONDITION 13 – INSTALLATION. ALL MOLDED BODIES TO HAVE FIVE YEAR WARRANTY.

Item #

30H SAP Number: 6006236

Item Name: TABLE, ICE COOLED COLD – OPEN BASE – 60-61”

Description: Body to be constructed of fiberglass panels with vertical and horizontal stainless steel trim or 18-8 type 304 stainless steel with smooth exterior surfaces and rounded corners. All fiberglass to be flame retardant per specifications ASTM E-162. To be 30" wide x 60" - 61" long and available in 34", 35", and 36" heights. Body constructed to accommodate tray rail at heights of 32", 33", and 34". (Bid does not include tray rail.) Top to be fabricated from 14 gauge stainless steel with square turndown on all sides and corners fully welded, ground, and polished with #4 finish. Body constructed with internal support member fabricated of a minimum of 12 gauge galvaneal channel to securely fasten tray rail support brackets. Provide with 6" stainless steel adjustable legs. Internal framing is to be 4-1/2" wide, galvaneal channel, shall be mounted vertically on front and rear surfaces and across the interior bottom to form a "U" shaped channel frame. "U" frame mounted at leg attachment location. "U" channel to be 3-1/2" – 4-1/2" wide on operators side. Exterior 20 gauge stainless steel channel mounted between bottom of fiberglass body and legs to provide maximum stress relief. **(See Section 6.1-ILLUSTRATIONS)**

The ice cold pan to be 18 gauge stainless steel and 6" deep. Pan to be welded, watertight and fully insulated with urethane insulation and removable false bottom. To have full perimeter Formica breaker strip to separate the top from the cold pan. To have drain with extension to shut-off valve below base. Open under storage to be lined with 18 gauge stainless steel **coved vertical and horizontal corners**. With 6" stainless steel adjustable legs. U.L. Listed and N.S.F. Approved.

Warranty: Two year manufacturer’s warranty, all parts and labor must be included in the unit price.

Approved Brands: Colorpoint Model 60-CFI, Delfield Model KCI-60-NU-MB or other brands meeting bid specifications

Brand Offered: _____

Model Offered: _____

Warranty Period: _____

Delivery (days ARO): _____

SECTION 6 - BID SPECIFICATIONS (CONTINUED)

In order to be considered for award, Bidders must fill these Bid Specifications Forms and the Electronic Bid Summary Sheet and submit them with their bid, in time for bid opening.

GROUP ITEM 30 NOTES:

1. SERVING LINES MAY BE ORDERED IN ANY CONFIGURATION OF ITEMS INCLUDED IN GROUP 31.
2. AWARDED VENDOR IS NOT RESPONSIBLE FOR ELECTRICAL OR PLUMBING HOOK-UP.
3. FOR THIS GROUP OF ITEMS, BIDDER MUST OFFER ITEMS FROM THE SAME MANUFACTURER.
4. SEE SPECIAL CONDITION 13 – INSTALLATION. ALL MOLDED BODIES TO HAVE FIVE YEAR WARRANTY.

Item #

30 I SAP Number: 6006237

Item Name: TABLE, ICE COOLED COLD – OPEN BASE – 66 3/8"

Description: Body to be constructed of fiberglass panels with vertical and horizontal stainless steel trim or 18-8 type 304 stainless steel with smooth exterior surfaces and rounded corners. All fiberglass to be flame retardant per specifications ASTM E-162. To be 30" wide x 66" – 67" long and available in 34", 35", and 36" heights. Body constructed to accommodate tray rail at heights of 32", 33", and 34" (Bid does not include tray rail). Top to be fabricated from 14 gauge stainless steel with square turndown on all sides and corners fully welded, ground, and polished with #4 finish. Body constructed with internal support member fabricated of a minimum of 12 gauge galvaneal channel to securely fasten tray rail support brackets. Provide with 6" stainless steel adjustable legs. Internal framing is to be 4-1/2" wide, galvaneal channel, shall be mounted vertically on front and rear surfaces and across the interior bottom to form a "U" shaped channel frame. "U" frame mounted at leg attachment location. "U" channel to be 3-1/2" – 4-1/2" wide on operators side. Exterior 20 gauge stainless steel channel mounted between bottom of fiberglass body and legs to provide maximum stress relief. **(See Section 6.1-ILLUSTRATIONS)**

The ice cold pan to be 18 gauge stainless steel and 6" deep. Pan to be welded, watertight and fully insulated with urethane insulation and removable false bottom. To have full perimeter Formica breaker strip to separate the top from the cold pan. To have drain with extension to shut-off valve below base. Storage for 3 each 12" x 20" steamable pans in the cold pan and one 18" x 26" steet pan on the flat top. Open under storage to be lined with 18 gauge stainless steel **covered vertical and horizontal corners**. With 6" stainless steel adjustable legs. U.L. Listed and N.S.F. Approved.

Warranty: Two year manufacturer's warranty, all parts and labor must be included in the unit price.

Approved Brands: Colorpoint Model 66-CFI MOD, Delfield Model KCI-66-NU-MB MOD or other brands meeting bid specifications

Brand Offered: _____

Model Offered: _____

Warranty Period: _____

Delivery (days ARO): _____

SECTION 6 - BID SPECIFICATIONS (CONTINUED)

In order to be considered for award, Bidders must fill these Bid Specifications Forms and the Electronic Bid Summary Sheet and submit them with their bid, in time for bid opening.

GROUP ITEM 30 NOTES:

1. SERVING LINES MAY BE ORDERED IN ANY CONFIGURATION OF ITEMS INCLUDED IN GROUP 31.
2. AWARDED VENDOR IS NOT RESPONSIBLE FOR ELECTRICAL OR PLUMBING HOOK-UP.
3. FOR THIS GROUP OF ITEMS, BIDDER MUST OFFER ITEMS FROM THE SAME MANUFACTURER.
4. SEE SPECIAL CONDITION 13 – INSTALLATION. ALL MOLDED BODIES TO HAVE FIVE YEAR WARRANTY.

Item #

30J SAP Number: 6006238

Item Name: TABLE, ICE COOLED COLD – OPEN BASE – 74 3/8"

Description: Body to be constructed of fiberglass panels with vertical and horizontal stainless steel trim or 18-8 type 304 stainless steel with smooth exterior surfaces and rounded corners. All fiberglass to be flame retardant per specifications ASTM E-162. To be 30" wide x 74" - 75" long and available in 34", 35", and 36" heights. Body constructed to accommodate tray rail at heights of 32", 33", and 34" (Bid does not include tray rail). Top to be fabricated from 14 gauge stainless steel with square turndown on all sides and corners fully welded, ground, and polished with #4 finish. Body constructed with internal support member fabricated of a minimum of 12 gauge galvaneal channel to securely fasten tray rail support brackets. Provide with 6" stainless steel adjustable legs. Internal framing is to be 4-1/2" wide, galvaneal channel, shall be mounted vertically on front and rear surfaces and across the interior bottom to form a "U" shaped channel frame. "U" frame mounted at leg attachment location. "U" channel to be 3-1/2" – 4-1/2" wide on operators side. Exterior 20 gauge stainless steel channel mounted between bottom of fiberglass body and legs to provide maximum stress relief. **(See Section 6.1-ILLUSTRATIONS)**

The ice cold pan to be 18 gauge stainless steel and 6" deep. Pan to be welded, watertight and fully insulated with urethane insulation and removable false bottom. To have full perimeter Formica breaker strip to separate the top from the cold pan. To have drain with extension to shut-off valve below base. Storage for 3 each 12" x 20" steamable pans in the cold pan and one 18" x 26" steel pan on the flat top. Open under storage to be lined with 18 gauge stainless **steel covered vertical and horizontal corners**. With 6" stainless steel adjustable legs. U.L. Listed and N.S.F. Approved.

Warranty: Two year manufacturer's warranty, all parts and labor must be included in the unit price.

Approved Brands: Colorpoint Model 74-CFI MOD, Delfield Model KCI-74-NU-MB MOD or other brands meeting bid specifications

Brand Offered: _____

Model Offered: _____

Warranty Period: _____

Delivery (days ARO): _____

SECTION 6 - BID SPECIFICATIONS (CONTINUED)

In order to be considered for award, Bidders must fill these Bid Specifications Forms and the Electronic Bid Summary Sheet and submit them with their bid, in time for bid opening.

GROUP ITEM 30 NOTES:

1. SERVING LINES MAY BE ORDERED IN ANY CONFIGURATION OF ITEMS INCLUDED IN GROUP 31.
2. AWARDED VENDOR IS NOT RESPONSIBLE FOR ELECTRICAL OR PLUMBING HOOK-UP.
3. FOR THIS GROUP OF ITEMS, BIDDER MUST OFFER ITEMS FROM THE SAME MANUFACTURER.
4. SEE SPECIAL CONDITION 13 – INSTALLATION. ALL MOLDED BODIES TO HAVE FIVE YEAR WARRANTY.

Item #

30K SAP Number: 6001122

Item Name: TABLE, SOLID TOP WITH OPEN BASE – 30” (SERVING LINE)

Description: Body to be seamless mold fiberglass with smooth exterior surfaces and rounded corners or 18-8 type 304 stainless steel with smooth exterior surfaces and rounded corners. All fiberglass to be flame retardant per specifications ASTM E-162. To be 28" - 30" wide x 30" long and available in 34", 35", and 36" heights. Body constructed to accommodate tray rail at heights of 32", 33", and 34". (Bid does not include tray rail.) Top to be fabricated from 14 gauge stainless steel with square turndown on all sides and corners fully welded, ground, and polished with #4 finish. Provide with six inch stainless steel adjustable legs. Body constructed with internal support member fabricated of a minimum of 12 gauge galvaneal channel to securely fasten tray rail support brackets. Internal framing is to be 4-1/2" wide, galvaneal channel, shall be mounted vertically on front and rear surfaces and across the interior bottom to form a "U" shaped channel frame. "U" frame mounted at leg attachment location. "U" channel to be 3-1/2" – 4-1/2" wide on operators side. Exterior 20 gauge stainless steel channel mounted between bottom of fiberglass body and legs to provide maximum stress relief. **(See Section 6.1-ILLUSTRATIONS)**

Open under storage to be lined with 18 gauge stainless steel with coved vertical and horizontal corners.

Warranty: Two year manufacturer's warranty, all parts and labor to be included in the unit price.

Approved Brands: Colorpoint Model 28-ST Modified, Delfield Model KC-28-NU-MB or other brands meeting bid specifications.

Brand Offered: _____

Model Offered: _____

Warranty Period: _____

Delivery (days ARO): _____

SECTION 6 - BID SPECIFICATIONS (CONTINUED)

In order to be considered for award, Bidders must fill these Bid Specifications Forms and the Electronic Bid Summary Sheet and submit them with their bid, in time for bid opening.

GROUP ITEM 30 NOTES:

1. SERVING LINES MAY BE ORDERED IN ANY CONFIGURATION OF ITEMS INCLUDED IN GROUP 31.
2. AWARDED VENDOR IS NOT RESPONSIBLE FOR ELECTRICAL OR PLUMBING HOOK-UP.
3. FOR THIS GROUP OF ITEMS, BIDDER MUST OFFER ITEMS FROM THE SAME MANUFACTURER.
4. SEE SPECIAL CONDITION 13 – INSTALLATION. ALL MOLDED BODIES TO HAVE FIVE YEAR WARRANTY.

Item #

30L SAP Number: 6001119

Item Name: TABLE, SOLID TOP WITH OPEN BASE – 36” (SERVING LINE)

Description: Body to be seamless mold fiberglass with smooth exterior surfaces and rounded corners or 18-8 type 304 stainless steel with smooth exterior surfaces and rounded corners. All fiberglass to be flame retardant per specifications ASTM E-162. To be 28" - 30" wide x 36" long and available in 34", 35", and 36" heights. Body constructed to accommodate tray rail at heights of 32", 33", and 34". (Bid does not include tray rail.) Top to be fabricated from 14 gauge stainless steel with square turndown on all sides and corners fully welded, ground, and polished with #4 finish. Provide with six inch stainless steel adjustable legs. Body constructed with internal support member fabricated of a minimum of 12 gauge galvaneal channel to securely fasten tray rail support brackets. Internal framing is to be 4-1/2" wide, galvaneal channel, shall be mounted vertically on front and rear surfaces and across the interior bottom to form a "U" shaped channel frame. "U" frame mounted at leg attachment location. "U" channel to be 3-1/2" – 4-1/2" wide on operators side. Exterior 20 gauge stainless steel channel mounted between bottom of fiberglass body and legs to provide maximum stress relief. **(See Section 6.1-ILLUSTRATIONS)**

Open under storage to be lined with 18 gauge stainless steel with coved vertical and horizontal corners. An intermediate shelf shall have the rear and ends turned up and secured to interior liner.

Warranty: Two year manufacturer's warranty, all parts and labor to be included in the unit price.

Approved Brands: Colorpoint Model 36-ST, Delfield Model KC-36-NU-MB or other brands meeting bid specifications

Brand Offered: _____

Model Offered: _____

Warranty Period: _____

Delivery (days ARO): _____

SECTION 6 - BID SPECIFICATIONS (CONTINUED)

In order to be considered for award, Bidders must fill these Bid Specifications Forms and the Electronic Bid Summary Sheet and submit them with their bid, in time for bid opening.

GROUP ITEM 30 NOTES:

1. SERVING LINES MAY BE ORDERED IN ANY CONFIGURATION OF ITEMS INCLUDED IN GROUP 31.
2. AWARDED VENDOR IS NOT RESPONSIBLE FOR ELECTRICAL OR PLUMBING HOOK-UP.
3. FOR THIS GROUP OF ITEMS, BIDDER MUST OFFER ITEMS FROM THE SAME MANUFACTURER.
4. SEE SPECIAL CONDITION 13 – INSTALLATION. ALL MOLDED BODIES TO HAVE FIVE YEAR WARRANTY.

Item #

30M SAP Number: 6001146

Item Name: TABLE, SOLID TOP WITH OPEN BASE – 42” (SERVING LINE)

Description: Body to be constructed of fiberglass panels with vertical and horizontal stainless steel trim or 18-8 type 304 stainless steel with smooth exterior surfaces and rounded corners. All fiberglass to be flame retardant per specifications ASTM-162. To be 38" - 30" wide x approx. 42" long. Must accommodate two each 18" x 26" bun pans sitting side by side. Available in 34", 35", and 36" heights. Body constructed to accommodate tray rail at heights of 32", 33", and 34". (Bid does not include tray rail.) Top to be fabricated from 14 gauge stainless steel with square turndown on all sides and corners fully welded, ground, and polished with #4 finish. Provide with six inch stainless steel adjustable legs. Body constructed with internal support member fabricated of a minimum of 12 gauge galvaneal channel to securely fasten tray rail support brackets. Internal framing is to be 4-1/2" wide, galvaneal channel, shall be mounted vertically on front and rear surfaces and across the interior bottom to form a "U" shaped channel frame. "U" frame mounted at leg attachment location. "U" channel to be 3-1/2" – 4-1/2" wide on operators side. Exterior 20 gauge stainless steel channel mounted between bottom of fiberglass body and legs to provide maximum stress relief. **(See Section 6.1-ILLUSTRATIONS)**

Open under storage to be lined with 18 gauge stainless steel with covered vertical and horizontal corners. An intermediate shelf shall have the rear and ends turned up and secured to interior liner.

Warranty: Two year manufacturer's warranty, all parts and labor to be included in the unit price.

Approved Brands: Colorpoint Model 36ST-MOD, Delfield Model KC-36-NU-MB or other brands meeting bid specifications

Brand Offered: _____

Model Offered: _____

Warranty Period: _____

Delivery (days ARO): _____

SECTION 6 - BID SPECIFICATIONS (CONTINUED)

In order to be considered for award, Bidders must fill these Bid Specifications Forms and the Electronic Bid Summary Sheet and submit them with their bid, in time for bid opening.

GROUP ITEM 30 NOTES:

1. SERVING LINES MAY BE ORDERED IN ANY CONFIGURATION OF ITEMS INCLUDED IN GROUP 31.
2. AWARDED VENDOR IS NOT RESPONSIBLE FOR ELECTRICAL OR PLUMBING HOOK-UP.
3. FOR THIS GROUP OF ITEMS, BIDDER MUST OFFER ITEMS FROM THE SAME MANUFACTURER.
4. SEE SPECIAL CONDITION 13 – INSTALLATION. ALL MOLDED BODIES TO HAVE FIVE YEAR WARRANTY.

Item #

30N SAP Number: 6000100

Item Name: TABLE, SOLID TOP WITH OPEN BASE – 50” (SERVING LINE)

Description: Body to be seamless mold fiberglass with smooth exterior surfaces and rounded corners or 18-8 type 304 stainless steel with smooth exterior surfaces and rounded corners. All fiberglass to be flame retardant per specifications ASTM E-162. To be 28" - 30" wide x 50" long and available in 34", 35", and 36" heights. Body constructed to accommodate tray rail at heights of 32", 33", and 34". (Bid does not include tray rail.) Top to be fabricated from 14 gauge stainless steel with square turndown on all sides and corners fully welded, ground, and polished with #4 finish. Provide with six inch stainless steel adjustable legs. Body constructed with internal support member fabricated of a minimum of 12 gauge galvaneal channel to securely fasten tray rail support brackets. Internal framing is to be 4-1/2" wide, galvaneal channel, shall be mounted vertically on front and rear surfaces and across the interior bottom to form a "U" shaped channel frame. "U" frame mounted at leg attachment location. "U" channel to be 3-1/2" – 4-1/2" wide on operators side. Exterior 20 gauge stainless steel channel mounted between bottom of fiberglass body and legs to provide maximum stress relief. **(See Section 6.1-ILLUSTRATIONS)**

Open under storage to be lined with 18 gauge stainless steel with coved vertical and horizontal corners. An intermediate shelf shall have the rear and ends turned up and secured to interior liner.

Warranty: Two year manufacturer’s warranty, all parts and labor must be included in the unit price.

Approved Brands: Colorpoint Model 50-ST, Delfield Model KC-50-NU-MB or other brands meeting bid specifications

Brand Offered: _____

Model Offered: _____

Warranty Period: _____

Delivery (days ARO): _____

SECTION 6 - BID SPECIFICATIONS (CONTINUED)

In order to be considered for award, Bidders must fill these Bid Specifications Forms and the Electronic Bid Summary Sheet and submit them with their bid, in time for bid opening.

GROUP ITEM 30 NOTES:

1. SERVING LINES MAY BE ORDERED IN ANY CONFIGURATION OF ITEMS INCLUDED IN GROUP 31.
2. AWARDED VENDOR IS NOT RESPONSIBLE FOR ELECTRICAL OR PLUMBING HOOK-UP.
3. FOR THIS GROUP OF ITEMS, BIDDER MUST OFFER ITEMS FROM THE SAME MANUFACTURER.
4. SEE SPECIAL CONDITION 13 – INSTALLATION. ALL MOLDED BODIES TO HAVE FIVE YEAR WARRANTY.

Item #

30 O SAP Number: 6001120

Item Name: TABLE, SOLID TOP WITH OPEN BASE – 60” (SERVING LINE)

Description: Body to be seamless mold fiberglass with smooth exterior surfaces and rounded corners or 18-8 type 304 stainless steel with smooth exterior surfaces and rounded corners. All fiberglass to be flame retardant per specifications ASTM E-162. To be 28" - 30" wide x 60" long and available in 34", 35", and 36" heights. Body constructed to accommodate tray rail at heights of 32", 33", and 34". (Bid does not include tray rail.) Top to be fabricated from 14 gauge stainless steel with square turndown on all sides and corners fully welded, ground, and polished with #4 finish. Provide with six inch stainless steel adjustable legs. Body constructed with internal support member fabricated of a minimum of 12 gauge galvaneal channel to securely fasten tray rail support brackets. Internal framing is to be 4-1/2" wide, galvaneal channel, shall be mounted vertically on front and rear surfaces and across the interior bottom to form a "U" shaped channel frame. "U" frame mounted at leg attachment location. "U" channel to be 3-1/2" – 4-1/2" wide on operators side. Exterior 20 gauge stainless steel channel mounted between bottom of fiberglass body and legs to provide maximum stress relief. **(See Section 6.1-ILLUSTRATIONS)**

Open under storage to be lined with 18 gauge stainless steel with **coved vertical and horizontal corners**. An intermediate shelf shall have the rear and ends turned up and secured to interior liner.

Warranty: Two year manufacturer’s warranty, all parts and labor must be included in the unit price.

Approved Brands: Colorpoint Model 60-ST, Delfield Model KC-60-NU-MB or other brands meeting bid specifications

Brand Offered: _____

Model Offered: _____

Warranty Period: _____

Delivery (days ARO): _____

SECTION 6 - BID SPECIFICATIONS (CONTINUED)

In order to be considered for award, Bidders must fill these Bid Specifications Forms and the Electronic Bid Summary Sheet and submit them with their bid, in time for bid opening.

GROUP ITEM 30 NOTES:

1. SERVING LINES MAY BE ORDERED IN ANY CONFIGURATION OF ITEMS INCLUDED IN GROUP 31.
2. AWARDED VENDOR IS NOT RESPONSIBLE FOR ELECTRICAL OR PLUMBING HOOK-UP.
3. FOR THIS GROUP OF ITEMS, BIDDER MUST OFFER ITEMS FROM THE SAME MANUFACTURER.
4. SEE SPECIAL CONDITION 13 – INSTALLATION. ALL MOLDED BODIES TO HAVE FIVE YEAR WARRANTY.

Item #

30P SAP Number: 6001158

Item Name: TABLE, SOLID TOP WITH OPEN BASE – 66” (SERVING LINE)

Description: Body to be seamless mold fiberglass with smooth exterior surfaces and rounded corners or 18-8 type 304 stainless steel with smooth exterior surfaces and rounded corners. All fiberglass to be flame retardant per specifications ASTM E-162. To be 28" - 30" wide x 66" long and available in 34", 35", and 36" heights. Body constructed to accommodate tray rail at heights of 32", 33", and 34". (Bid does not include tray rail.) Top to be fabricated from 14 gauge stainless steel with square turndown on all sides and corners fully welded, ground, and polished with #4 finish. Provide with six inch stainless steel adjustable legs. Body constructed with internal support member fabricated of a minimum of 12 gauge galvaneal channel to securely fasten tray rail support brackets. Internal framing is to be 4-1/2" wide, galvaneal channel, shall be mounted vertically on front and rear surfaces and across the interior bottom to form a "U" shaped channel frame. "U" frame mounted at leg attachment location. "U" channel to be 3-1/2" – 4-1/2" wide on operators side. Exterior 20 gauge stainless steel channel mounted between bottom of fiberglass body and legs to provide maximum stress relief. **(See Section 6.1-ILLUSTRATIONS)**

Open under storage to be lined with 18 gauge stainless steel with covered vertical and horizontal corners. An intermediate shelf shall have the rear and ends turned up and secured to interior liner.

Warranty: Two year manufacturer’s warranty, all parts and labor must be included in the unit price.

Approved Brands: Colorpoint Model 66-ST, Delfield Model KC-60-NU-MB or other brands meeting bid specifications

Brand Offered: _____

Model Offered: _____

Warranty Period: _____

Delivery (days ARO): _____

SECTION 6 - BID SPECIFICATIONS (CONTINUED)

In order to be considered for award, Bidders must fill these Bid Specifications Forms and the Electronic Bid Summary Sheet and submit them with their bid, in time for bid opening.

GROUP ITEM 30 NOTES:

1. SERVING LINES MAY BE ORDERED IN ANY CONFIGURATION OF ITEMS INCLUDED IN GROUP 31.
2. AWARDED VENDOR IS NOT RESPONSIBLE FOR ELECTRICAL OR PLUMBING HOOK-UP.
3. FOR THIS GROUP OF ITEMS, BIDDER MUST OFFER ITEMS FROM THE SAME MANUFACTURER.
4. SEE SPECIAL CONDITION 13 – INSTALLATION. ALL MOLDED BODIES TO HAVE FIVE YEAR WARRANTY.

Item #

30Q SAP Number: 6001121

Item Name: TABLE, SOLID TOP WITH OPEN BASE – 74” (SERVING LINE)

Description: Body to be seamless mold fiberglass with smooth exterior surfaces and rounded corners or 18-8 type 304 stainless steel with smooth exterior surfaces and rounded corners. All fiberglass to be flame retardant per specifications ASTM E-162. To be 28" - 30" wide x 74" long and available in 34", 35", and 36" heights. Body constructed to accommodate tray rail at heights of 32", 33", and 34". (Bid does not include tray rail.) Top to be fabricated from 14 gauge stainless steel with square turndown on all sides and corners fully welded, ground, and polished with #4 finish. Provide with six inch stainless steel adjustable legs. Body constructed with internal support member fabricated of a minimum of 12 gauge galvaneal channel to securely fasten tray rail support brackets. Internal framing is to be 4-1/2" wide, galvaneal channel, shall be mounted vertically on front and rear surfaces and across the interior bottom to form a "U" shaped channel frame. "U" frame mounted at leg attachment location. "U" channel to be 3-1/2" – 4-1/2" wide on operators side. Exterior 20 gauge stainless steel channel mounted between bottom of fiberglass body and legs to provide maximum stress relief. **(See Section 6.1-ILLUSTRATIONS)**

Open under storage to be lined with 18 gauge stainless steel with **coved vertical and horizontal corners**. An intermediate shelf shall have the rear and ends turned up and secured to interior liner.

Warranty: Two year manufacturer’s warranty, all parts and labor must be included in the unit price.

Approved Brands: Colorpoint Model 74-ST, Delfield Model KC-74-NU-MB or other brands meeting bid specifications

Brand Offered: _____

Model Offered: _____

Warranty Period: _____

Delivery (days ARO): _____

SECTION 6 - BID SPECIFICATIONS (CONTINUED)

In order to be considered for award, Bidders must fill these Bid Specifications Forms and the Electronic Bid Summary Sheet and submit them with their bid, in time for bid opening.

GROUP ITEM 30 NOTES:

1. SERVING LINES MAY BE ORDERED IN ANY CONFIGURATION OF ITEMS INCLUDED IN GROUP 31.
2. AWARDED VENDOR IS NOT RESPONSIBLE FOR ELECTRICAL OR PLUMBING HOOK-UP.
3. FOR THIS GROUP OF ITEMS, BIDDER MUST OFFER ITEMS FROM THE SAME MANUFACTURER.
4. SEE SPECIAL CONDITION 13 – INSTALLATION. ALL MOLDED BODIES TO HAVE FIVE YEAR WARRANTY.

Item #

30R SAP Number: 6000112

Item Name: SLIDE, SOLID TRAY – 28”

Description: 14 Gauge stainless steel with three inverted "V" ridges on surface. Ends and side turned down square with all corners fully welded, ground, and polished. Support brackets to be stainless steel. Tray slide bracket mounted through fiberglass body and secures to vertical section of internal "U" frame. Brackets must have adjustment screw to allow for proper alignment of tray slide front edge to maintain continuity of tray slide system
(See Section 6.1-ILLUSTRATIONS).
Manufacturer's standard warranty will apply.

Approved Brands: Colorpoint Model Option A 28”, Delfield Model A-28 or other brands meeting bid specifications

Brand Offered: _____

Model Offered: _____

Warranty Period: _____
Delivery
(days ARO): _____

Item #

30S SAP Number: 6001157

Item Name: SLIDE, SOLID TRAY – 30”

Description: 14 Gauge stainless steel with three inverted "V" ridges on surface. Ends and side turned down square with all corners fully welded, ground, and polished. Support brackets for tray rail stainless steel. Tray slide bracket mounted through fiberglass body and secures to vertical section of internal "U" frame. Brackets must have adjustment screw to allow for proper alignment of tray slide front edge to maintain continuity of tray slide system.
(See Section 6.1-ILLUSTRATIONS)
Manufacturer's standard warranty will apply.

Approved Brands: Colorpoint Model Option A 30”, Delfield Model A-30 or other brands meeting bid specifications

Brand Offered: _____

Model Offered: _____

Warranty Period: _____
Delivery
(days ARO): _____

SECTION 6 - BID SPECIFICATIONS (CONTINUED)

In order to be considered for award, Bidders must fill these Bid Specifications Forms and the Electronic Bid Summary Sheet and submit them with their bid, in time for bid opening.

GROUP ITEM 30 NOTES:

- 1. SERVING LINES MAY BE ORDERED IN ANY CONFIGURATION OF ITEMS INCLUDED IN GROUP 31.
- 2. AWARDED VENDOR IS NOT RESPONSIBLE FOR ELECTRICAL OR PLUMBING HOOK-UP.
- 3. FOR THIS GROUP OF ITEMS, BIDDER MUST OFFER ITEMS FROM THE SAME MANUFACTURER.
- 4. SEE SPECIAL CONDITION 13 – INSTALLATION. ALL MOLDED BODIES TO HAVE FIVE YEAR WARRANTY.

Item #

30T SAP Number: 6001124

Item Name: SLIDE, SOLID TRAY – 36”

Description: 14 Gauge stainless steel with three inverted "V" ridges on surface. Ends and side turned down square with all corners fully welded, ground, and polished. Support brackets to be stainless steel. Tray slide bracket mounted through fiberglass body and secures to vertical section of internal "U" frame. Brackets must have adjustment screw to allow for proper alignment of tray slide front edge to maintain continuity of tray slide system **(See Section 6.1-ILLUSTRATIONS)**.

Manufacturer's standard warranty will apply.

Approved Brands: Colorpoint Model Option A 36”, Delfield Model A-36 or other brands meeting bid specifications

Brand Offered: _____

Model Offered: _____

Warranty Period: _____
Delivery
(days ARO): _____

Item #

30U SAP Number: 6001150

Item Name: SLIDE, SOLID TRAY – 42”

Description: 14 Gauge stainless steel with three inverted "V" ridges on surface. Ends and side turned down square with all corners fully welded, ground, and polished. Support brackets for tray rail stainless steel. Tray slide bracket mounted through fiberglass body and secures to vertical section of internal "U" frame. Brackets must have adjustment screw to allow for proper alignment of tray slide front edge to maintain continuity of tray slide system. **(See Section 6.1-ILLUSTRATIONS)**

Manufacturer's standard warranty will apply.

Approved Brands: Colorpoint Model Option A 42”, Delfield Model A-42 or other brands meeting bid specifications

Brand Offered: _____

Model Offered: _____

Warranty Period: _____
Delivery
(days ARO): _____

SECTION 6 - BID SPECIFICATIONS (CONTINUED)

In order to be considered for award, Bidders must fill these Bid Specifications Forms and the Electronic Bid Summary Sheet and submit them with their bid, in time for bid opening.

GROUP ITEM 30 NOTES:

1. SERVING LINES MAY BE ORDERED IN ANY CONFIGURATION OF ITEMS INCLUDED IN GROUP 31.
2. AWARDED VENDOR IS NOT RESPONSIBLE FOR ELECTRICAL OR PLUMBING HOOK-UP.
3. FOR THIS GROUP OF ITEMS, BIDDER MUST OFFER ITEMS FROM THE SAME MANUFACTURER.
4. SEE SPECIAL CONDITION 13 – INSTALLATION. ALL MOLDED BODIES TO HAVE FIVE YEAR WARRANTY.

Item #

30V SAP Number: 6000101

Item Name: SLIDE, SOLID TRAY – 50"

Description: 14 Gauge stainless steel with three inverted "V" ridges on surface. Ends and side turned down square with all corners fully welded, ground, and polished. Support brackets to be stainless steel. Tray slide bracket mounted through fiberglass body and secures to vertical section of internal "U" frame. Brackets must have adjustment screw to allow for proper alignment of tray slide front edge to maintain continuity of tray slide system **(See Section 6.1-ILLUSTRATIONS)**.

Manufacturer's standard warranty will apply.

Approved Brands: Colorpoint Model Option A 50", Delfield Model A-50 or other brands meeting bid specifications

Brand Offered: _____

Model Offered: _____

Warranty Period: _____
Delivery
(days ARO): _____

Item #

30W SAP Number: 6000102

Item Name: SLIDE, SOLID TRAY – 60"

Description: 14 Gauge stainless steel with three inverted "V" ridges on surface. Ends and side turned down square with all corners fully welded, ground, and polished. Support brackets for tray rail stainless steel. Tray slide bracket mounted through fiberglass body and secures to vertical section of internal "U" frame. Brackets must have adjustment screw to allow for proper alignment of tray slide front edge to maintain continuity of tray slide system. **(See Section 6.1-ILLUSTRATIONS)**

Manufacturer's standard warranty will apply.

Approved Brands: Colorpoint Model Option A 60", Delfield Model A-60 or other brands meeting bid specifications

Brand Offered: _____

Model Offered: _____

Warranty Period: _____
Delivery
(days ARO): _____

SECTION 6 - BID SPECIFICATIONS (CONTINUED)

In order to be considered for award, Bidders must fill these Bid Specifications Forms and the Electronic Bid Summary Sheet and submit them with their bid, in time for bid opening.

GROUP ITEM 30 NOTES:

- 1. SERVING LINES MAY BE ORDERED IN ANY CONFIGURATION OF ITEMS INCLUDED IN GROUP 31.
- 2. AWARDED VENDOR IS NOT RESPONSIBLE FOR ELECTRICAL OR PLUMBING HOOK-UP.
- 3. FOR THIS GROUP OF ITEMS, BIDDER MUST OFFER ITEMS FROM THE SAME MANUFACTURER.
- 4. SEE SPECIAL CONDITION 13 – INSTALLATION. ALL MOLDED BODIES TO HAVE FIVE YEAR WARRANTY.

Item #

30X SAP Number: 6001151

Item Name: SLIDE, SOLID TRAY – 66”

Description: 14 Gauge stainless steel with three inverted "V" ridges on surface. Ends and side turned down square with all corners fully welded, ground, and polished. Support brackets to be stainless steel. Tray slide bracket mounted through fiberglass body and secures to vertical section of internal "U" frame. Brackets must have adjustment screw to allow for proper alignment of tray slide front edge to maintain continuity of tray slide system **(See Section 6.1-ILLUSTRATIONS)**.

Manufacturer's standard warranty will apply.

Approved Brands: Colorpoint Model Option A 66”, Delfield Model A-66 or other brands meeting bid specifications

Brand Offered: _____

Model Offered: _____

Warranty Period: _____
Delivery (days ARO): _____

Item #

30Y SAP Number: 6000102

Item Name: SLIDE, SOLID TRAY – 74”

Description: 14 Gauge stainless steel with three inverted "V" ridges on surface. Ends and side turned down square with all corners fully welded, ground, and polished. Support brackets for tray rail stainless steel. Tray slide bracket mounted through fiberglass body and secures to vertical section of internal "U" frame. Brackets must have adjustment screw to allow for proper alignment of tray slide front edge to maintain continuity of tray slide system. **(See Section 6.1-ILLUSTRATIONS)**

Manufacturer's standard warranty will apply.

Approved Brands: Colorpoint Model Option A 74”, Delfield Model A-74 or other brands meeting bid specifications

Brand Offered: _____

Model Offered: _____

Warranty Period: _____
Delivery (days ARO): _____

SECTION 6 - BID SPECIFICATIONS (CONTINUED)

In order to be considered for award, Bidders must fill these Bid Specifications Forms and the Electronic Bid Summary Sheet and submit them with their bid, in time for bid opening.

GROUP ITEM 30 NOTES:

1. SERVING LINES MAY BE ORDERED IN ANY CONFIGURATION OF ITEMS INCLUDED IN GROUP 31.
2. AWARDED VENDOR IS NOT RESPONSIBLE FOR ELECTRICAL OR PLUMBING HOOK-UP.
3. FOR THIS GROUP OF ITEMS, BIDDER MUST OFFER ITEMS FROM THE SAME MANUFACTURER.
4. SEE SPECIAL CONDITION 13 – INSTALLATION. ALL MOLDED BODIES TO HAVE FIVE YEAR WARRANTY.

Item #

30Z SAP Number: 6000116

Item Name: BOARD, CUTTING – 50” (SERVING LINE)

Description: Constructed of 14 gauge stainless steel, eight inch wide with edges turned down square on all corners fully welded, ground, and polished. Complete with stainless steel fold down bracket. Tray slide bracket mounted through fiberglass body and secures to vertical section of internal “U” frame. Brackets must have adjustment screw to allow for proper alignment of tray slide front edge to maintain continuity of tray slide system. **(See Section 6.1-ILLUSTRATIONS)**
Manufacturer’s standard warranty will apply.

Approved Brands: Colorpoint Model Option D50”, Delfield Model E-50 or other brands meeting bid specifications

Brand Offered: _____

Model Offered: _____

Warranty Period: _____
Delivery
(days ARO): _____

Item #

30AA SAP Number: 6001125

Item Name: BOARD, CUTTING – 60” (SERVING LINE)

Description: Constructed of 14 gauge stainless steel, eight inch wide with edges turned down square on all corners fully welded, ground, and polished. Complete with stainless steel fold down bracket. Tray slide bracket mounted through fiberglass body and secures to vertical section of internal “U” frame. Brackets must have adjustment screw to allow for proper alignment of tray slide front edge to maintain continuity of tray slide system. **(See Section 6.1-ILLUSTRATIONS)**
Manufacturer’s standard warranty will apply.

Approved Brands: Colorpoint Model Option D60”, Delfield Model E-60 or other brands meeting bid specifications

Brand Offered: _____

Model Offered: _____

Warranty Period: _____
Delivery
(days ARO): _____

SECTION 6 - BID SPECIFICATIONS (CONTINUED)

In order to be considered for award, Bidders must fill these Bid Specifications Forms and the Electronic Bid Summary Sheet and submit them with their bid, in time for bid opening.

GROUP ITEM 30 NOTES:

1. SERVING LINES MAY BE ORDERED IN ANY CONFIGURATION OF ITEMS INCLUDED IN GROUP 31.
2. AWARDED VENDOR IS NOT RESPONSIBLE FOR ELECTRICAL OR PLUMBING HOOK-UP.
3. FOR THIS GROUP OF ITEMS, BIDDER MUST OFFER ITEMS FROM THE SAME MANUFACTURER.
4. SEE SPECIAL CONDITION 13 – INSTALLATION. ALL MOLDED BODIES TO HAVE FIVE YEAR WARRANTY.

SECTION 6 - BID SPECIFICATIONS (CONTINUED)

In order to be considered for award, Bidders must fill these Bid Specifications Forms and the Electronic Bid Summary Sheet and submit them with their bid, in time for bid opening.

GROUP ITEM 30 NOTES:

- 1. SERVING LINES MAY BE ORDERED IN ANY CONFIGURATION OF ITEMS INCLUDED IN GROUP 31.
- 2. AWARDED VENDOR IS NOT RESPONSIBLE FOR ELECTRICAL OR PLUMBING HOOK-UP.
- 3. FOR THIS GROUP OF ITEMS, BIDDER MUST OFFER ITEMS FROM THE SAME MANUFACTURER.
- 4. SEE SPECIAL CONDITION 13 – INSTALLATION. ALL MOLDED BODIES TO HAVE FIVE YEAR WARRANTY.

Item #

30BB SAP Number: 6001126

Item Name: BOARD, CUTTING – 74” (SERVING LINE)

Description: Constructed of 14 gauge stainless steel, eight inch wide with edges turned down square on all corners fully welded, ground, and polished. Complete with stainless steel fold down bracket. Tray slide bracket mounted through fiberglass body and secures to vertical section of internal “U” frame. Brackets must have adjustment screw to allow for proper alignment of tray slide front edge to maintain continuity of tray slide system. **(See Section 6.1-ILLUSTRATIONS)**

Manufacturer’s standard warranty will apply.

Approved Brands: Colorpoint Model Option D74”, Delfield Model E-74 or other brands meeting bid specifications

Brand Offered: _____

Model Offered: _____

Warranty Period: _____
Delivery (days ARO): _____

Item #

30CC SAP Number: 6001152

Item Name: PROTECTOR, SLOPED FRONT FOOD – 50” (SERVING LINE)

Description: Shall have an 18 gauge stainless steel top serving shelf with all edges turned down square and all corners fully welded, ground, and polished. Ends sloped front glass to be 1/4” polished plate glass with one inch bottom clearance. All glass to be bound in stainless steel channel to prevent chipping. Manufacturer’s standard warranty will apply.

Approved Brands: Colorpoint Option G 50”, Delfield G-50 or other brands meeting bid specifications

Brand Offered: _____

Model Offered: _____

Warranty Period: _____
Delivery (days ARO): _____

SECTION 6 - BID SPECIFICATIONS (CONTINUED)

In order to be considered for award, Bidders must fill these Bid Specifications Forms and the Electronic Bid Summary Sheet and submit them with their bid, in time for bid opening.

GROUP ITEM 30 NOTES:

1. SERVING LINES MAY BE ORDERED IN ANY CONFIGURATION OF ITEMS INCLUDED IN GROUP 31.
2. AWARDED VENDOR IS NOT RESPONSIBLE FOR ELECTRICAL OR PLUMBING HOOK-UP.
3. FOR THIS GROUP OF ITEMS, BIDDER MUST OFFER ITEMS FROM THE SAME MANUFACTURER.
4. SEE SPECIAL CONDITION 13 – INSTALLATION. ALL MOLDED BODIES TO HAVE FIVE YEAR WARRANTY.

Item #

30DD SAP Number: 6001131

Item Name: PROTECTOR, SLOPED FRONT FOOD – 60” (SERVING LINE)

Description: Shall have an 18 gauge stainless steel top serving shelf with all edges turned down square and all corners fully welded, ground, and polished. Ends sloped front glass to be 1/4" polished plate glass with one inch bottom clearance. All glass to be bound in stainless steel channel to prevent chipping. Manufacturer’s standard warranty will apply.

Approved Brands: Colorpoint Option G 60", Delfield G-60 or other brands meeting bid specifications

Brand Offered: _____

Model Offered: _____

Warranty Period: _____
Delivery (days ARO): _____

Item #

30EE SAP Number: 6001132

Item Name: PROTECTOR, SLOPED FRONT FOOD – 74” (SERVING LINE)

Description: Shall have an 18 gauge stainless steel top serving shelf with all edges turned down square and all corners fully welded, ground, and polished. Ends sloped front glass to be 1/4" polished plate glass with one inch bottom clearance. All glass to be bound in stainless steel channel to prevent chipping. Manufacturer’s standard warranty will apply.

Approved Brands: Colorpoint Option G 74", Delfield G-74 or other brands meeting bid specifications

Brand Offered: _____

Model Offered: _____

Warranty Period: _____
Delivery (days ARO): _____

SECTION 6 - BID SPECIFICATIONS (CONTINUED)

In order to be considered for award, Bidders must fill these Bid Specifications Forms and the Electronic Bid Summary Sheet and submit them with their bid, in time for bid opening.

GROUP ITEM 30 NOTES:

1. SERVING LINES MAY BE ORDERED IN ANY CONFIGURATION OF ITEMS INCLUDED IN GROUP 31.
2. AWARDED VENDOR IS NOT RESPONSIBLE FOR ELECTRICAL OR PLUMBING HOOK-UP.
3. FOR THIS GROUP OF ITEMS, BIDDER MUST OFFER ITEMS FROM THE SAME MANUFACTURER.
4. SEE SPECIAL CONDITION 13 – INSTALLATION. ALL MOLDED BODIES TO HAVE FIVE YEAR WARRANTY.

Item #

30FF SAP Number: 6001153

Item Name: PROTECTOR, SINGLE SERVICE BUFFET, 30" (SERVING LINE)

Description: Shall have a Plexiglas sneeze guard along one side with Plexiglas enclosures. A removable top cap shelf of 16 gauge stainless steel with sides turned down square and all corners fully welded, ground, and polished. Unit to be mounted on one inch stainless steel tubular supports. Shield to have adjustable height from five inch opening to eight inch opening in increments of one inch without the use of tools. Manufacturer's standard warranty will apply.

Approved Brands: Colorpoint Option M 30", Delfield KS-28 or other brands meeting bid specifications

Brand Offered: _____

Model Offered: _____

Warranty Period: _____
Delivery
(days ARO): _____

Item #

30GG SAP Number: 6001154

Item Name: PROTECTOR, SINGLE SERVICE BUFFET, 36" (SERVING LINE)

Description: Shall have a Plexiglas sneeze guard along one side with Plexiglas enclosures. A removable top cap shelf of 16 gauge stainless steel with sides turned down square and all corners fully welded, ground, and polished. Unit to be mounted on one inch stainless steel tubular supports. Shield to have adjustable height from five inch opening to eight inch opening in increments of one inch without the use of tools. Manufacturer's standard warranty will apply.

Approved Brands: Colorpoint Option M 36", Delfield KS-36 or other brands meeting bid specifications

Brand Offered: _____

Model Offered: _____

Warranty Period: _____
Delivery
(days ARO): _____

SECTION 6 - BID SPECIFICATIONS (CONTINUED)

In order to be considered for award, Bidders must fill these Bid Specifications Forms and the Electronic Bid Summary Sheet and submit them with their bid, in time for bid opening.

GROUP ITEM 30 NOTES:

- 1. SERVING LINES MAY BE ORDERED IN ANY CONFIGURATION OF ITEMS INCLUDED IN GROUP 31.
- 2. AWARDED VENDOR IS NOT RESPONSIBLE FOR ELECTRICAL OR PLUMBING HOOK-UP.
- 3. FOR THIS GROUP OF ITEMS, BIDDER MUST OFFER ITEMS FROM THE SAME MANUFACTURER.
- 4. SEE SPECIAL CONDITION 13 – INSTALLATION. ALL MOLDED BODIES TO HAVE FIVE YEAR WARRANTY.

Item #

30HH SAP Number: 6001133

Item Name: PROTECTOR, SINGLE SERVICE BUFFET, 42" (SERVING LINE)

Description: Shall have a Plexiglas sneeze guard along one side with Plexiglas enclosures. A removable top cap shelf of 16 gauge stainless steel with sides turned down square and all corners fully welded, ground, and polished. Unit to be mounted on one inch stainless steel tubular supports. Shield to have adjustable height from five inch opening to eight inch opening in increments of one inch without the use of tools. Manufacturer's standard warranty will apply.

Approved Brands: Colorpoint Option M 42", Delfield KS-42 or other brands meeting bid specifications

Brand Offered: _____

Model Offered: _____

Warranty Period: _____
Delivery (days ARO): _____

Item #

30 II SAP Number: 6001134

Item Name: PROTECTOR, SINGLE SERVICE BUFFET, 50" (SERVING LINE)

Description: Shall have a Plexiglas sneeze guard along one side with Plexiglas enclosures. A removable top cap shelf of 16 gauge stainless steel with sides turned down square and all corners fully welded, ground, and polished. Unit to be mounted on one inch stainless steel tubular supports. Shield to have adjustable height from five inch opening to eight inch opening in increments of one inch without the use of tools. Manufacturer's standard warranty will apply.

Approved Brands: Colorpoint Option M 50", Delfield KS-50 or other brands meeting bid specifications

Brand Offered: _____

Model Offered: _____

Warranty Period: _____
Delivery (days ARO): _____

SECTION 6 - BID SPECIFICATIONS (CONTINUED)

In order to be considered for award, Bidders must fill these Bid Specifications Forms and the Electronic Bid Summary Sheet and submit them with their bid, in time for bid opening.

GROUP ITEM 30 NOTES:

1. SERVING LINES MAY BE ORDERED IN ANY CONFIGURATION OF ITEMS INCLUDED IN GROUP 31.
2. AWARDED VENDOR IS NOT RESPONSIBLE FOR ELECTRICAL OR PLUMBING HOOK-UP.
3. FOR THIS GROUP OF ITEMS, BIDDER MUST OFFER ITEMS FROM THE SAME MANUFACTURER.
4. SEE SPECIAL CONDITION 13 – INSTALLATION. ALL MOLDED BODIES TO HAVE FIVE YEAR WARRANTY.

Item #

30JJ SAP Number: 6001135

Item Name: PROTECTOR, SINGLE SERVICE BUFFET, 60" (SERVING LINE)

Description: Shall have a Plexiglas sneeze guard along one side with Plexiglas enclosures. A removable top cap shelf of 16 gauge stainless steel with sides turned down square and all corners fully welded, ground, and polished. Unit to be mounted on one inch stainless steel tubular supports. Shield to have adjustable height from five inch opening to eight inch opening in increments of one inch without the use of tools. Manufacturer's standard warranty will apply.

Approved Brands: Colorpoint Option M 36", Delfield KS-60 or other brands meeting bid specifications

Brand Offered: _____

Model Offered: _____

Warranty Period: _____
Delivery
(days ARO): _____

Item #

30KK SAP Number: 6001155

Item Name: PROTECTOR, SINGLE SERVICE BUFFET, 66" (SERVING LINE)

Description: Shall have a Plexiglas sneeze guard along one side with Plexiglas enclosures. A removable top cap shelf of 16 gauge stainless steel with sides turned down square and all corners fully welded, ground, and polished. Unit to be mounted on one inch stainless steel tubular supports. Shield to have adjustable height from five inch opening to eight inch opening in increments of one inch without the use of tools. Manufacturer's standard warranty will apply.

Approved Brands: Colorpoint Option M 66", Delfield KS-66 or other brands meeting bid specifications

Brand Offered: _____

Model Offered: _____

Warranty Period: _____
Delivery
(days ARO): _____

SECTION 6 - BID SPECIFICATIONS (CONTINUED)

In order to be considered for award, Bidders must fill these Bid Specifications Forms and the Electronic Bid Summary Sheet and submit them with their bid, in time for bid opening.

GROUP ITEM 30 NOTES:

1. SERVING LINES MAY BE ORDERED IN ANY CONFIGURATION OF ITEMS INCLUDED IN GROUP 31.
2. AWARDED VENDOR IS NOT RESPONSIBLE FOR ELECTRICAL OR PLUMBING HOOK-UP.
3. FOR THIS GROUP OF ITEMS, BIDDER MUST OFFER ITEMS FROM THE SAME MANUFACTURER.
4. SEE SPECIAL CONDITION 13 – INSTALLATION. ALL MOLDED BODIES TO HAVE FIVE YEAR WARRANTY.

Item #

30LL SAP Number: 6001136

Item Name: PROTECTOR, SINGLE SERVICE BUFFET, 74" (SERVING LINE)

Description: Shall have a Plexiglas sneeze guard along one side with Plexiglas enclosures. A removable top cap shelf of 16 gauge stainless steel with sides turned down square and all corners fully welded, ground, and polished. Unit to be mounted on one inch stainless steel tubular supports. Shield to have adjustable height from five inch opening to eight inch opening in increments of one inch without the use of tools. Manufacturer's standard warranty will apply.

Approved Brands: Colorpoint Option M74 ", Delfield KS-74 or other brands meeting bid specifications

Brand Offered: _____

Model Offered: _____

Warranty Period: _____
Delivery (days ARO): _____

Item #

30MM SAP Number: 6001156

Item Name: DISPLAY, TWO TIER – 30" (SERVING LINE)

Description: With sloped front stand shall have 1-1/4" square stainless steel tubing with stainless steel cap and base. Shelves to be 1/4" polished plate glass resting on a horizontal stainless steel framework welded to the uprights. The display sneeze guard to be mounted on adjustable stainless steel brackets. Manufacturer's standard warranty will apply.

Approved Brands: Colorpoint Option I 30", Delfield H-28 or other brands meeting bid specifications

Brand Offered: _____

Model Offered: _____

Warranty Period: _____
Delivery (days ARO): _____

SECTION 6 - BID SPECIFICATIONS (CONTINUED)

In order to be considered for award, Bidders must fill these Bid Specifications Forms and the Electronic Bid Summary Sheet and submit them with their bid, in time for bid opening.

GROUP ITEM 30 NOTES:

1. SERVING LINES MAY BE ORDERED IN ANY CONFIGURATION OF ITEMS INCLUDED IN GROUP 31.
2. AWARDED VENDOR IS NOT RESPONSIBLE FOR ELECTRICAL OR PLUMBING HOOK-UP.
3. FOR THIS GROUP OF ITEMS, BIDDER MUST OFFER ITEMS FROM THE SAME MANUFACTURER.
4. SEE SPECIAL CONDITION 13 – INSTALLATION. ALL MOLDED BODIES TO HAVE FIVE YEAR WARRANTY.

Item #

30NN SAP Number: 6001127

Item Name: DISPLAY, TWO TIER – 36" (SERVING LINE)

Description: With sloped front stand shall have 1-1/4" square stainless steel tubing with stainless steel cap and base. Shelves to be 1/4" polished plate glass resting on a horizontal stainless steel framework welded to the uprights. The display sneeze guard to be mounted on adjustable stainless steel brackets. Manufacturer's standard warranty will apply.

Approved Brands: Colorpoint Option I 36", Delfield H-36 or other brands meeting bid specifications

Brand Offered: _____

Model Offered: _____

Warranty Period: _____
Delivery (days ARO): _____

Item #

30 OO SAP Number: 6001147

Item Name: DISPLAY, TWO TIER – 42" (SERVING LINE)

Description: With sloped front stand shall have 1-1/4" square stainless steel tubing with stainless steel cap and base. Shelves to be 1/4" polished plate glass resting on a horizontal stainless steel framework welded to the uprights. The display sneeze guard to be mounted on adjustable stainless steel brackets. Manufacturer's standard warranty will apply.

Approved Brands: Colorpoint Option I 42", Delfield H-42 or other brands meeting bid specifications

Brand Offered: _____

Model Offered: _____

Warranty Period: _____
Delivery (days ARO): _____

SECTION 6 - BID SPECIFICATIONS (CONTINUED)

In order to be considered for award, Bidders must fill these Bid Specifications Forms and the Electronic Bid Summary Sheet and submit them with their bid, in time for bid opening.

GROUP ITEM 30 NOTES:

1. SERVING LINES MAY BE ORDERED IN ANY CONFIGURATION OF ITEMS INCLUDED IN GROUP 31.
2. AWARDED VENDOR IS NOT RESPONSIBLE FOR ELECTRICAL OR PLUMBING HOOK-UP.
3. FOR THIS GROUP OF ITEMS, BIDDER MUST OFFER ITEMS FROM THE SAME MANUFACTURER.
4. SEE SPECIAL CONDITION 13 – INSTALLATION. ALL MOLDED BODIES TO HAVE FIVE YEAR WARRANTY.

Item #

30PP SAP Number: 6000104

Item Name: DISPLAY, TWO TIER – 50" (SERVING LINE)

Description: With sloped front stand shall have 1-1/4" square stainless steel tubing with stainless steel cap and base. Shelves to be 1/4" polished plate glass resting on a horizontal stainless steel framework welded to the uprights. The display sneeze guard to be mounted on adjustable stainless steel brackets. Manufacturer's standard warranty will apply.

Approved Brands: Colorpoint Option I 50", Delfield H-50 or other brands meeting bid specifications

Brand Offered: _____

Model Offered: _____

Warranty Period: _____
Delivery (days ARO): _____

Item #

30QQ SAP Number: 6000105

Item Name: DISPLAY, TWO TIER – 60" (SERVING LINE)

Description: With sloped front stand shall have 1-1/4" square stainless steel tubing with stainless steel cap and base. Shelves to be 1/4" polished plate glass resting on a horizontal stainless steel framework welded to the uprights. The display sneeze guard to be mounted on adjustable stainless steel brackets. Manufacturer's standard warranty will apply.

Approved Brands: Colorpoint Option I 60", Delfield H-60 or other brands meeting bid specifications

Brand Offered: _____

Model Offered: _____

Warranty Period: _____
Delivery (days ARO): _____

SECTION 6 - BID SPECIFICATIONS (CONTINUED)

In order to be considered for award, Bidders must fill these Bid Specifications Forms and the Electronic Bid Summary Sheet and submit them with their bid, in time for bid opening.

GROUP ITEM 30 NOTES:

1. SERVING LINES MAY BE ORDERED IN ANY CONFIGURATION OF ITEMS INCLUDED IN GROUP 31.
2. AWARDED VENDOR IS NOT RESPONSIBLE FOR ELECTRICAL OR PLUMBING HOOK-UP.
3. FOR THIS GROUP OF ITEMS, BIDDER MUST OFFER ITEMS FROM THE SAME MANUFACTURER.
4. SEE SPECIAL CONDITION 13 – INSTALLATION. ALL MOLDED BODIES TO HAVE FIVE YEAR WARRANTY.

Item #

30RR SAP Number: 6001159

Item Name: DISPLAY, TWO TIER – 66" (SERVING LINE)

Description: With sloped front stand shall have 1-1/4" square stainless steel tubing with stainless steel cap and base. Shelves to be 1/4" polished plate glass resting on a horizontal stainless steel framework welded to the uprights. The display sneeze guard to be mounted on adjustable stainless steel brackets. Manufacturer's standard warranty will apply.

Approved Brands: Colorpoint Option I 66", Delfield H-60 MOD or other brands meeting bid specifications

Brand Offered: _____

Model Offered: _____

Warranty Period: _____

Delivery (days ARO): _____

SECTION 6 - BID SPECIFICATIONS (CONTINUED)

In order to be considered for award, Bidders must fill these Bid Specifications Forms and the Electronic Bid Summary Sheet and submit them with their bid, in time for bid opening.

GROUP ITEM 30 NOTES:

- 1. SERVING LINES MAY BE ORDERED IN ANY CONFIGURATION OF ITEMS INCLUDED IN GROUP 31.
- 2. AWARDED VENDOR IS NOT RESPONSIBLE FOR ELECTRICAL OR PLUMBING HOOK-UP.
- 3. FOR THIS GROUP OF ITEMS, BIDDER MUST OFFER ITEMS FROM THE SAME MANUFACTURER.
- 4. SEE SPECIAL CONDITION 13 – INSTALLATION. ALL MOLDED BODIES TO HAVE FIVE YEAR WARRANTY.

Item #

30SS SAP Number: 6000106

Item Name: DISPLAY, TWO TIER – 74” (SERVING LINE)

Description: With sloped front stand shall have 1-1/4" square stainless steel tubing with stainless steel cap and base. Shelves to be 1/4" polished plate glass resting on a horizontal stainless steel framework welded to the uprights. The display sneeze guard to be mounted on adjustable stainless steel brackets. Manufacturer's standard warranty will apply.

Approved Brands: Colorpoint Option I 74", Delfield H-74 or other brands meeting bid specifications

Brand Offered: _____

Model Offered: _____

Warranty Period: _____
Delivery
(days ARO): _____

Item #

30TT SAP Number: 6001164

Item Name: STAND, THREE TIER DISPLAY 28-30” (SERVING LINE)

Description: With sloped front stand shall have 1-1/4" square stainless steel tubing with stainless steel cap and base. Shelves to be 1/4" polished plate glass resting on a horizontal stainless steel framework welded to the uprights. The display sneeze guard to be mounted on adjustable stainless steel brackets. Manufacturer's standard warranty will apply.

Approved Brands: Colorpoint Option K 30", Delfield Model I-28 or other brands meeting bid specifications

Brand Offered: _____

Model Offered: _____

Warranty Period: _____
Delivery
(days ARO): _____

SECTION 6 - BID SPECIFICATIONS (CONTINUED)

In order to be considered for award, Bidders must fill these Bid Specifications Forms and the Electronic Bid Summary Sheet and submit them with their bid, in time for bid opening.

GROUP ITEM 30 NOTES:

- 1. SERVING LINES MAY BE ORDERED IN ANY CONFIGURATION OF ITEMS INCLUDED IN GROUP 31.
- 2. AWARDED VENDOR IS NOT RESPONSIBLE FOR ELECTRICAL OR PLUMBING HOOK-UP.
- 3. FOR THIS GROUP OF ITEMS, BIDDER MUST OFFER ITEMS FROM THE SAME MANUFACTURER.
- 4. SEE SPECIAL CONDITION 13 – INSTALLATION. ALL MOLDED BODIES TO HAVE FIVE YEAR WARRANTY.

Item #

30UU SAP Number: 6001137

Item Name: STAND, THREE TIER DISPLAY 36" (SERVING LINE)

Description: With sloped front stand shall have 1-1/4" square stainless steel tubing with stainless steel cap and base. Shelves to be 1/4" polished plate glass resting on a horizontal stainless steel framework welded to the uprights. The display sneeze guard to be mounted on adjustable stainless steel brackets. Manufacturer's standard warranty will apply.

Approved Brands: Colorpoint Option K 36", Delfield Model I-36 or other brands meeting bid specifications

Brand Offered: _____

Model Offered: _____

Warranty Period: _____
Delivery
(days ARO): _____

Item #

30V V SAP Number: 6001160

Item Name: STAND, THREE TIER DISPLAY 42" (SERVING LINE)

Description: With sloped front stand shall have 1-1/4" square stainless steel tubing with stainless steel cap and base. Shelves to be 1/4" polished plate glass resting on a horizontal stainless steel framework welded to the uprights. The display sneeze guard to be mounted on adjustable stainless steel brackets. Manufacturer's standard warranty will apply.

Approved Brands: Colorpoint Option K 42", Delfield Model I-42 or other brands meeting bid specifications

Brand Offered: _____

Model Offered: _____

Warranty Period: _____
Delivery
(days ARO): _____

SECTION 6 - BID SPECIFICATIONS (CONTINUED)

In order to be considered for award, Bidders must fill these Bid Specifications Forms and the Electronic Bid Summary Sheet and submit them with their bid, in time for bid opening.

GROUP ITEM 30 NOTES:

1. SERVING LINES MAY BE ORDERED IN ANY CONFIGURATION OF ITEMS INCLUDED IN GROUP 31.
2. AWARDED VENDOR IS NOT RESPONSIBLE FOR ELECTRICAL OR PLUMBING HOOK-UP.
3. FOR THIS GROUP OF ITEMS, BIDDER MUST OFFER ITEMS FROM THE SAME MANUFACTURER.
4. SEE SPECIAL CONDITION 13 – INSTALLATION. ALL MOLDED BODIES TO HAVE FIVE YEAR WARRANTY.

Item #

30W W SAP Number: 6001138

Item Name: STAND, THREE TIER DISPLAY 50" (SERVING LINE)

Description: With sloped front stand shall have 1-1/4" square stainless steel tubing with stainless steel cap and base. Shelves to be 1/4" polished plate glass resting on a horizontal stainless steel framework welded to the uprights. The display sneeze guard to be mounted on adjustable stainless steel brackets. Manufacturer's standard warranty will apply.

Approved Brands: Colorpoint Option K 50", Delfield Model I-50 or other brands meeting bid specifications

Brand Offered: _____

Model Offered: _____

Warranty Period: _____
Delivery (days ARO): _____

Item #

30XX SAP Number: 6001139

Item Name: STAND, THREE TIER DISPLAY 60" (SERVING LINE)

Description: With sloped front stand shall have 1-1/4" square stainless steel tubing with stainless steel cap and base. Shelves to be 1/4" polished plate glass resting on a horizontal stainless steel framework welded to the uprights. The display sneeze guard to be mounted on adjustable stainless steel brackets. Manufacturer's standard warranty will apply.

Approved Brands: Colorpoint Option K 60", Delfield Model I-60 or other brands meeting bid specifications

Brand Offered: _____

Model Offered: _____

Warranty Period: _____
Delivery (days ARO): _____

SECTION 6 - BID SPECIFICATIONS (CONTINUED)

In order to be considered for award, Bidders must fill these Bid Specifications Forms and the Electronic Bid Summary Sheet and submit them with their bid, in time for bid opening.

GROUP ITEM 30 NOTES:

- 1. SERVING LINES MAY BE ORDERED IN ANY CONFIGURATION OF ITEMS INCLUDED IN GROUP 31.
- 2. AWARDED VENDOR IS NOT RESPONSIBLE FOR ELECTRICAL OR PLUMBING HOOK-UP.
- 3. FOR THIS GROUP OF ITEMS, BIDDER MUST OFFER ITEMS FROM THE SAME MANUFACTURER.
- 4. SEE SPECIAL CONDITION 13 – INSTALLATION. ALL MOLDED BODIES TO HAVE FIVE YEAR WARRANTY.

Item #

30YY SAP Number: 6001161

Item Name: STAND, THREE TIER DISPLAY 66" (SERVING LINE)

Description: With sloped front stand shall have 1-1/4" square stainless steel tubing with stainless steel cap and base. Shelves to be 1/4" polished plate glass resting on a horizontal stainless steel framework welded to the uprights. The display sneeze guard to be mounted on adjustable stainless steel brackets. Manufacturer's standard warranty will apply.

Approved Brands: Colorpoint Option K 66", Delfield Model I-66-MOD or other brands meeting bid specifications *

Brand Offered: _____

Model Offered: _____

Warranty Period: _____
Delivery (days ARO): _____

Item #

30ZZ SAP Number: 6001140

Item Name: STAND, THREE TIER DISPLAY 74" (SERVING LINE)

Description: With sloped front stand shall have 1-1/4" square stainless steel tubing with stainless steel cap and base. Shelves to be 1/4" polished plate glass resting on a horizontal stainless steel framework welded to the uprights. The display sneeze guard to be mounted on adjustable stainless steel brackets. Manufacturer's standard warranty will apply.

Approved Brands: Colorpoint Option K 74", Delfield Model I-74 or other brands meeting bid specifications

Brand Offered: _____

Model Offered: _____

Warranty Period: _____
Delivery (days ARO): _____

SECTION 6 - BID SPECIFICATIONS (CONTINUED)

In order to be considered for award, Bidders must fill these Bid Specifications Forms and the Electronic Bid Summary Sheet and submit them with their bid, in time for bid opening.

GROUP ITEM 30 NOTES:

1. SERVING LINES MAY BE ORDERED IN ANY CONFIGURATION OF ITEMS INCLUDED IN GROUP 31.
2. AWARDED VENDOR IS NOT RESPONSIBLE FOR ELECTRICAL OR PLUMBING HOOK-UP.
3. FOR THIS GROUP OF ITEMS, BIDDER MUST OFFER ITEMS FROM THE SAME MANUFACTURER.
4. SEE SPECIAL CONDITION 13 – INSTALLATION. ALL MOLDED BODIES TO HAVE FIVE YEAR WARRANTY.

Item #

30AAA SAP Number: 6000108
Item Name: LOCKS, LINE UP – SERVING LINE
Description: To be barrel bolt and key slot design with cam locking action. Locks to be placed on opposing corners for maximum versatility. Manufacturer’s standard warranty will apply.
Approved Brands: Colorpoint Option AA, Delfield “F” or other brands meeting bid specifications
Brand Offered: _____
Model Offered: _____
Warranty Period: _____
Delivery (days ARO): _____

Item #

30BBB SAP Number: 6001129
Item Name: OUTLET, CONVENIENCE – SERVING LINE
Description: Flush mount type, to be 120 VAC prewired and fused as required. Receptacle to be recessed in stainless steel housing on a body surface. Manufacturer’s standard warranty will apply.
Approved Brands: Colorpoint Option, Delfield “Q” or other brands meeting bid specifications
Brand Offered: _____
Model Offered: _____
Warranty Period: _____
Delivery (days ARO): _____

SECTION 6 - BID SPECIFICATIONS (CONTINUED)

In order to be considered for award, Bidders must fill these Bid Specifications Forms and the Electronic Bid Summary Sheet and submit them with their bid, in time for bid opening.

GROUP ITEM 30 NOTES:

- 1. SERVING LINES MAY BE ORDERED IN ANY CONFIGURATION OF ITEMS INCLUDED IN GROUP 31.
- 2. AWARDED VENDOR IS NOT RESPONSIBLE FOR ELECTRICAL OR PLUMBING HOOK-UP.
- 3. FOR THIS GROUP OF ITEMS, BIDDER MUST OFFER ITEMS FROM THE SAME MANUFACTURER.
- 4. SEE SPECIAL CONDITION 13 – INSTALLATION. ALL MOLDED BODIES TO HAVE FIVE YEAR WARRANTY.

Item #

30CCC SAP Number: 6001130

Item Name: SHELF, END DROP – SERVING LINE

Description: To be 16 gauge stainless steel 30" x 12" wide with edges turned down square and all corners fully welded, ground, and polished. Support brackets to be stainless steel. Manufacturer's standard warranty will apply.

Approved Brands: Colorpoint Option FF, Delfield "U" or other brands meeting bid specifications

Brand Offered: _____

Model Offered: _____

Warranty Period: _____
Delivery (days ARO): _____

Item #

30DDD SAP Number: 6001128

Item Name: STRIP, HEAT LAMP – 60" (SERVING LINE)

Description: With lights shall have food safe incandescent lamps built into the heat lamp housing and wired to a separate ON/OFF switch as required. This heat lamp is to be mounted to the top tier of Option I. Lamp and light to be Hatco #GRAL or other brands meeting bid specifications. Manufacturer's standard warranty will apply.

Approved Brands: Colorpoint Option U 60", Delfield M-60 or other brands meeting bid specifications

Brand Offered: _____

Model Offered: _____

Warranty Period: _____
Delivery (days ARO): _____

SECTION 6 - BID SPECIFICATIONS (CONTINUED)

In order to be considered for award, Bidders must fill these Bid Specifications Forms and the Electronic Bid Summary Sheet and submit them with their bid, in time for bid opening.

GROUP ITEM 30 NOTES:

1. SERVING LINES MAY BE ORDERED IN ANY CONFIGURATION OF ITEMS INCLUDED IN GROUP 31.
2. AWARDED VENDOR IS NOT RESPONSIBLE FOR ELECTRICAL OR PLUMBING HOOK-UP.
3. FOR THIS GROUP OF ITEMS, BIDDER MUST OFFER ITEMS FROM THE SAME MANUFACTURER.
4. SEE SPECIAL CONDITION 13 – INSTALLATION. ALL MOLDED BODIES TO HAVE FIVE YEAR WARRANTY.

Item #

30EEE SAP Number: 6000107

Item Name: STRIP, HEAT LAMP – 74” (SERVING LINE)

Description: With lights shall have food safe incandescent lamps built into the heat lamp housing and wired to a separate ON/OFF switch as required. This heat lamp is to be mounted to the top tier of Option I. Lamp and light to be Hatco #GRAL or other brands meeting bid specifications. Manufacturer's standard warranty will apply.

Approved Brands: Colorpoint Option U 74", Delfield M-74 or other brands meeting bid specifications

Brand Offered: _____

Model Offered: _____

Warranty Period: _____
Delivery (days ARO): _____

Item #

30FFF SAP Number: 6001162

Item Name: BULB, HEAT LAMP – 60” (SERVING LINE)

Description: Food safe bullet type to be secured to the underside of the top cap of buffet shields. Bulb holder to have porcelain socket and stainless steel conical bulb protector. Each lamp is individually wired to ON/OFF switch. Complete with four each 40 watt incandescent bulbs. Manufacturer's standard warranty will apply.

Approved Brands: Colorpoint Option T 60", Delfield MB-4 or other brands meeting bid specifications

Brand Offered: _____

Model Offered: _____

Warranty Period: _____
Delivery (days ARO): _____

SECTION 6 - BID SPECIFICATIONS (CONTINUED)

In order to be considered for award, Bidders must fill these Bid Specifications Forms and the Electronic Bid Summary Sheet and submit them with their bid, in time for bid opening.

GROUP ITEM 30 NOTES:

1. SERVING LINES MAY BE ORDERED IN ANY CONFIGURATION OF ITEMS INCLUDED IN GROUP 31.
2. AWARDED VENDOR IS NOT RESPONSIBLE FOR ELECTRICAL OR PLUMBING HOOK-UP.
3. FOR THIS GROUP OF ITEMS, BIDDER MUST OFFER ITEMS FROM THE SAME MANUFACTURER.
4. SEE SPECIAL CONDITION 13 – INSTALLATION. ALL MOLDED BODIES TO HAVE FIVE YEAR WARRANTY.

Item #

30GGG SAP Number: 6001163

Item Name: BULB, HEAT LAMP – 74” (SERVING LINE)

Description: Food safe bullet type to be secured to the underside of the top cap of buffet shields. Bulb holder to have porcelain socket and stainless steel conical bulb protector. Each lamp is individually wired to ON/OFF switch. Complete with four each 40 watt incandescent bulbs. Manufacturer's standard warranty will apply.

Approved Brands: Colorpoint Option T 74", Delfield MB-5 or other brands meeting bid specifications

Brand Offered: _____

Model Offered: _____

Warranty Period: _____
Delivery (days ARO): _____

Item #

30HHH SAP Number: 6000118

Item Name: COLOR, CUSTOM UPGRADE – SERVING LINE

Description: Manufacturer's standard warranty will apply.

Approved Brands: Colorpoint Model CC-0001, Delfield Model "Custom Color" or other brands meeting bid specifications

Brand Offered: _____

Model Offered: _____

Warranty Period: _____
Delivery (days ARO): _____

SECTION 6 - BID SPECIFICATIONS (CONTINUED)

In order to be considered for award, Bidders must fill these Bid Specifications Forms and the Electronic Bid Summary Sheet and submit them with their bid, in time for bid opening.

GROUP ITEM 30 NOTES:

1. SERVING LINES MAY BE ORDERED IN ANY CONFIGURATION OF ITEMS INCLUDED IN GROUP 31.
2. AWARDED VENDOR IS NOT RESPONSIBLE FOR ELECTRICAL OR PLUMBING HOOK-UP.
3. FOR THIS GROUP OF ITEMS, BIDDER MUST OFFER ITEMS FROM THE SAME MANUFACTURER.
4. SEE SPECIAL CONDITION 13 – INSTALLATION. ALL MOLDED BODIES TO HAVE FIVE YEAR WARRANTY.

Item #

30III SAP Number: 6001142

Item Name: FRONT, FALSE – 64" (SERVING LINE)

Description: Top to be 14 gauge stainless steel with square turndown on all sides and corners fully welded, ground and polished. Top surface to have #4 finish and all edges to have #7 hi-lite finish. The exterior body form shall consist of 14 gauge stainless steel vertical and horizontal angle with all joints fully welded ground and polished making body frame one integral unit. Front panel shall be smooth fiberglass reinforced polyester (F.R.P.). Fiberglass to be flame retardant per ASTM specification E-162 having a flame spread of 25 or less. Rear exterior panel to be 18 gauge stainless steel formed to include end panels. False panel to include line up locks and flanged, adjustable bullet feet. Manufacturer's standard warranty will apply.

Approved Brands: Colorpoint 64" False Front, Delfield 64" False Front or other brands meeting bid specifications

Brand Offered: _____

Model Offered: _____

Warranty Period: _____

Delivery (days ARO): _____

SECTION 6 - BID SPECIFICATIONS (CONTINUED)

In order to be considered for award, Bidders must fill these Bid Specifications Forms and the Electronic Bid Summary Sheet and submit them with their bid, in time for bid opening.

GROUP ITEM 30 NOTES:

1. SERVING LINES MAY BE ORDERED IN ANY CONFIGURATION OF ITEMS INCLUDED IN GROUP 31.
2. AWARDED VENDOR IS NOT RESPONSIBLE FOR ELECTRICAL OR PLUMBING HOOK-UP.
3. FOR THIS GROUP OF ITEMS, BIDDER MUST OFFER ITEMS FROM THE SAME MANUFACTURER.
4. SEE SPECIAL CONDITION 13 – INSTALLATION. ALL MOLDED BODIES TO HAVE FIVE YEAR WARRANTY.

Item #

30JJJ SAP Number: 6000110

Item Name: STAND, CASHIER – SERVING LINE (28” LONG)

Description: Body to be seamless mold fiberglass reinforced polyester (F.R.P.) with smooth exterior surfaces and rounded corners. All fiberglass to be flame retardant per specifications ASTM E-162. To be 28" - 30" wide x 28" long. Top to be fabricated from 14 gauge stainless steel with square turndown on all sides and corners fully welded, ground, and polished with #4 finish. Complete with optional locking cash drawer. Internal framing is to be 4-1/2" wide, galvaneal channel, shall be mounted vertically on front and rear surfaces and across the interior bottom to form a "U" shaped channel frame. "U" frame mounted at leg attachment location. "U" channel to be 3-1/2" – 4-1/2" wide on operators side. Exterior 20 gauge stainless steel channel mounted between bottom of fiberglass body and legs to provide maximum stress relief. (See Section 6.1-ILLUSTRATIONS) Unit to have 4" diameter, ball bearing, swivel type casters to be non-marking and with brakes on two of four wheels. Casters mounted with exterior and interior bracing for maximum stress relief. NSF and UL listed.

Warranty: Two year warranty, all parts and labor must be included in the unit price.

Approved Brands: Colorpoint Model K-28-CSE, Delfield Model KCS-30 or other brands meeting bid specifications

Brand Offered: _____

Model Offered: _____

Warranty Period: _____

Delivery (days ARO): _____

SECTION 6 - BID SPECIFICATIONS (CONTINUED)

In order to be considered for award, Bidders must fill these Bid Specifications Forms and the Electronic Bid Summary Sheet and submit them with their bid, in time for bid opening.

GROUP ITEM 30 NOTES:

1. SERVING LINES MAY BE ORDERED IN ANY CONFIGURATION OF ITEMS INCLUDED IN GROUP 31.
2. AWARDED VENDOR IS NOT RESPONSIBLE FOR ELECTRICAL OR PLUMBING HOOK-UP.
3. FOR THIS GROUP OF ITEMS, BIDDER MUST OFFER ITEMS FROM THE SAME MANUFACTURER.
4. SEE SPECIAL CONDITION 13 – INSTALLATION. ALL MOLDED BODIES TO HAVE FIVE YEAR WARRANTY.

Item #

30KKK SAP Number: 6006240

Item Name: STAND, CASHIER – SERVING LINE (36" LONG)

Description: Body to be seamless mold fiberglass reinforced polyester (F.R.P.) with smooth exterior surfaces and rounded corners. All fiberglass to be flame retardant per specifications ASTM E-162. To be **28" - 30" wide x 36" long**. Top to be fabricated from 14 gauge stainless steel with square turndown on all sides and corners fully welded, ground, and polished with #4 finish. Complete with optional locking cash drawer. Internal framing is to be 4-1/2" wide, galvanneal channel, shall be mounted vertically on front and rear surfaces and across the interior bottom to form a "U" shaped channel frame. "U" frame mounted at leg attachment location. "U" channel to be 3-1/2" – 4-1/2" wide on operators side. Exterior 20 gauge stainless steel channel mounted between bottom of fiberglass body and legs to provide maximum stress relief. (See Section 6.1-ILLUSTRATIONS) Unit to have 4" diameter, ball bearing, swivel type casters to be non-marking and with brakes on two of four wheels. Casters mounted with exterior and interior bracing for maximum stress relief. NSF and UL listed.

Warranty: Two year warranty, all parts and labor must be included in the unit price.

Approved Brands: Colorpoint Model K-36-CSE, Delfield Model KCS-36 or other brands meeting bid specifications

Brand Offered: _____

Model Offered: _____

Warranty Period: _____

Delivery (days ARO): _____

SECTION 6 - BID SPECIFICATIONS (CONTINUED)

In order to be considered for award, Bidders must fill these Bid Specifications Forms and the Electronic Bid Summary Sheet and submit them with their bid, in time for bid opening.

GROUP ITEM 30 NOTES:

- 1. SERVING LINES MAY BE ORDERED IN ANY CONFIGURATION OF ITEMS INCLUDED IN GROUP 31.
- 2. AWARDED VENDOR IS NOT RESPONSIBLE FOR ELECTRICAL OR PLUMBING HOOK-UP.
- 3. FOR THIS GROUP OF ITEMS, BIDDER MUST OFFER ITEMS FROM THE SAME MANUFACTURER.
- 4. SEE SPECIAL CONDITION 13 – INSTALLATION. ALL MOLDED BODIES TO HAVE FIVE YEAR WARRANTY.

Item #

30LLL SAP Number: 6006241

Item Name: STAND, CASHIER – SERVING LINE (42” LONG)

Description: Body to be seamless mold fiberglass reinforced polyester (F.R.P.) with smooth exterior surfaces and rounded corners. All fiberglass to be flame retardant per specifications ASTM E-162. To be **28" - 30" wide x 42" long**. Top to be fabricated from 14 gauge stainless steel with square turndown on all sides and corners fully welded, ground, and polished with #4 finish. Complete with optional locking cash drawer. Internal framing is to be 4-1/2" wide, galvanneal channel, shall be mounted vertically on front and rear surfaces and across the interior bottom to form a "U" shaped channel frame. "U" frame mounted at leg attachment location. "U" channel to be 3-1/2" – 4-1/2" wide on operators side. Exterior 20 gauge stainless steel channel mounted between bottom of fiberglass body and legs to provide maximum stress relief. (See Section 6.1-ILLUSTRATIONS) Unit to have 4" diameter, ball bearing, swivel type casters to be non-marking and with brakes on two of four wheels. Casters mounted with exterior and interior bracing for maximum stress relief. NSF and UL listed.

Warranty: Two year warranty, all parts and labor must be included in the unit price.

Approved Brands: Colorpoint Model K-42-CSE, Delfield Model KCS-42 or other brands meeting bid specifications

Brand Offered: _____

Model Offered: _____

Warranty Period: _____

Delivery (days ARO): _____

SECTION 6 - BID SPECIFICATIONS (CONTINUED)

In order to be considered for award, Bidders must fill these Bid Specifications Forms and the Electronic Bid Summary Sheet and submit them with their bid, in time for bid opening.

GROUP ITEM 30 NOTES:

1. SERVING LINES MAY BE ORDERED IN ANY CONFIGURATION OF ITEMS INCLUDED IN GROUP 31.
2. AWARDED VENDOR IS NOT RESPONSIBLE FOR ELECTRICAL OR PLUMBING HOOK-UP.
3. FOR THIS GROUP OF ITEMS, BIDDER MUST OFFER ITEMS FROM THE SAME MANUFACTURER.
4. SEE SPECIAL CONDITION 13 – INSTALLATION. ALL MOLDED BODIES TO HAVE FIVE YEAR WARRANTY.

Item #

30MMM SAP Number: 6006242

Item Name: REFRIGERATED COLD TABLE – OPEN BASE – 50-51”

Description: Body to be constructed of fiberglass panels with vertical and horizontal stainless steel trim or 18-8 type 304 stainless steel with smooth exterior surfaces and rounded corners. All fiberglass to be flame retardant per specifications ASTM E-162. To be **34" wide x 50" - 51" long and available in 34", 35", and 36" heights**. Body constructed to accommodate tray rail at heights of 32", 33", and 34". (Bid does not include tray rail.) Top to be fabricated from 14 gauge stainless steel with square turndown on all sides and corners fully welded, ground, and polished with #4 finish. Body constructed with internal support member fabricated of a minimum of 12 gauge galvaneal channel to securely fasten tray rail support brackets. Provide with 6" stainless steel adjustable legs. Internal framing is to be 4-1/2" wide, galvaneal channel, shall be mounted vertically on front and rear surfaces and across the interior bottom to form a "U" shaped channel frame. "U" frame mounted at leg attachment location. "U" channel to be 3-1/2" – 4-1/2" wide on operators side. Exterior 20 gauge stainless steel channel mounted between bottom of fiberglass body and legs to provide maximum stress relief. **(See Section 6.1-ILLUSTRATIONS)**

Mechanical cold pan to be 18 gauge stainless steel fully welded construction with ¼" coved corners. The cold pan shall be pitched to a 1" drain which is extended to a valve below the base. All cold pans shall be furnished with urethane insulation on bottom and all four sides of pan. The pan shall be fully separated from the counter top by a full perimeter breaker strip. To accommodate a 6" deep full size pan. Temperature is maintained by a static air system utilizing ½" copper coils attached to the liner bottom and sides to a level 1" above food pans. To have a fully hermetic condensing unit operating on R-134A refrigerant. Food pans shall be supported by full length removable brackets located 3" below top. To have drain with extension to shut-off valve below base. Open under storage to be lined with 18 gauge stainless steel coved vertical and horizontal corners. With 6" stainless steel adjustable legs. U.L. Listed and N.S.F. Approved.

Warranty: Two year manufacturer’s warranty, all parts and labor must be included in the unit price.

Approved Brands: Colorpoint Model 50-CFMX, Delfield Model KCSC-50B or other brands meeting bid specifications

Brand Offered: _____

Model Offered: _____

Warranty Period: _____

Delivery (days ARO): _____

SECTION 6 - BID SPECIFICATIONS (CONTINUED)

In order to be considered for award, Bidders must fill these Bid Specifications Forms and the Electronic Bid Summary Sheet and submit them with their bid, in time for bid opening.

GROUP ITEM 30 NOTES:

1. SERVING LINES MAY BE ORDERED IN ANY CONFIGURATION OF ITEMS INCLUDED IN GROUP 31.
2. AWARDED VENDOR IS NOT RESPONSIBLE FOR ELECTRICAL OR PLUMBING HOOK-UP.
3. FOR THIS GROUP OF ITEMS, BIDDER MUST OFFER ITEMS FROM THE SAME MANUFACTURER.
4. SEE SPECIAL CONDITION 13 – INSTALLATION. ALL MOLDED BODIES TO HAVE FIVE YEAR WARRANTY.

Item #

30NNN SAP Number: 6006243

Item Name: REFRIGERATED COLD TABLE – OPEN BASE – 60-61”

Description: Body to be constructed of fiberglass panels with vertical and horizontal stainless steel trim or 18-8 type 304 stainless steel with smooth exterior surfaces and rounded corners. All fiberglass to be flame retardant per specifications ASTM E-162. To be 34" wide x 50" - 51" long and available in 34", 35", and 36" heights. Body constructed to accommodate tray rail at heights of 32", 33", and 34". (Bid does not include tray rail.) Top to be fabricated from 14 gauge stainless steel with square turndown on all sides and corners fully welded, ground, and polished with #4 finish. Body constructed with internal support member fabricated of a minimum of 12 gauge galvaneal channel to securely fasten tray rail support brackets. Provide with 6" stainless steel adjustable legs. Internal framing is to be 4-1/2" wide, galvaneal channel, shall be mounted vertically on front and rear surfaces and across the interior bottom to form a "U" shaped channel frame. "U" frame mounted at leg attachment location. "U" channel to be 3-1/2" – 4-1/2" wide on operators side. Exterior 20 gauge stainless steel channel mounted between bottom of fiberglass body and legs to provide maximum stress relief. **(See Section 6.1-ILLUSTRATIONS)**

Mechanical cold pan to be 18 gauge stainless steel fully welded construction with ¼" coved corners. The cold pan shall be pitched to a 1" drain which is extended to a valve below the base. All cold pans shall be furnished with urethane insulation on bottom and all four sides of pan. The pan shall be fully separated from the counter top by a full perimeter breaker strip. To accommodate a 6" deep full size pan. Temperature is maintained by a static air system utilizing ½" copper coils attached to the liner bottom and sides to a level 1" above food pans. To have a fully hermetic condensing unit operating on R-134A refrigerant. Food pans shall be supported by full length removable brackets located 3" below top. To have drain with extension to shut-off valve below base. Open under storage to be lined with 18 gauge stainless steel coved vertical and horizontal corners. With 6" stainless steel adjustable legs. U.L. Listed and N.S.F. Approved.

Warranty: Two year manufacturer’s warranty, all parts and labor must be included in the unit price.

Approved Brands: Colorpoint Model 60-CFMX, Delfield Model KCSC-60 or other brands meeting bid specifications

Brand Offered: _____

Model Offered: _____

Warranty Period: _____

Delivery (days ARO): _____

SECTION 6 - BID SPECIFICATIONS – (CONTINUED)

In order to be considered for award, Bidders must fill these Bid Specifications Forms and the Electronic Bid Summary Sheet and submit them with their bid, in time for bid opening.

ITEM 31 – TO BE AWARDED AS A GROUP

Item #

31A SAP Number: 6000815

Item Name: SCALE, DIGITAL DOUGH – HEAVY DUTY SUBMERSIBLE 10# CAPACITY

Description: Self-calibrating, all stainless steel body. NSF approved. Operates on batteries or UL/CE approved AC power supply. Power cord included. With Platform. Water-tight battery compartment. Approx. 6" x 6-3/4" one piece platform with corrosion protection. Weighs in pounds and ounces up to 10 lbs. and oz. increments of .1 oz. to 1/8 oz. Adjustable leveling feet.

Warranty: One year, all parts and labor to be included in the unit price.

Approved Brand: Edlund "Poseidon" Model WSC-10 with platform or other brands meeting bid specifications

Brand Offered: _____

Model Offered: _____

Warranty Period: _____
Delivery (days ARO): _____

Item #

31B SAP Number: 6004408

Item Name: SCALE, DIGITAL DOUGH – HEAVY DUTY SUBMERSIBLE 20# CAPACITY

Description: Self-calibrating, all stainless steel body. NSF approved. Operates on batteries or UL/CE approved AC power supply. Power cord included. To include platform. Water-tight battery compartment. Approx. 7" x 8-3/4" one piece platform with corrosion protection. Weighs in pounds and ounces up to 20 lbs. and oz. increments of .1 oz. to 1/8 oz. Adjustable leveling feet.

Warranty: One year, all parts and labor to be included in the unit price.

Approved Brand: Edlund "Poseidon" Model WSC-20OP or other brands meeting bid specifications

Brand Offered: _____

Model Offered: _____

Warranty Period: _____
Delivery (days ARO): _____

SECTION 6 - BID SPECIFICATIONS – (CONTINUED)

In order to be considered for award, Bidders must fill these Bid Specifications Forms and the Electronic Bid Summary Sheet and submit them with their bid, in time for bid opening.

Item #

32 SAP Number: 6000818

Item Name: SCALE, 25 POUND PORTION

Description: Constructed of heavy duty stainless steel inside and out to resist rusting. Measures up to 25 pounds in two ounce increments and larger one pound increments (metric not acceptable). Scale must be able to provide fast and accurate readings, and scale must show measurements in both ounces and pounds. Large fixed dial must be recessed with removable lexan face plate, and dial must contain large black numbers on a white surface with colored pointer. Diameter of dial to be approximately 8-1/2". Large stainless steel minimum 7" x 8-3/4" platform. Must have easy-to-turn adjusting but to calibrate scale.
Warranty: One year warranty, all parts and labor to be included in the unit price.

Approved Brand: Edlund Model RM-25 or other brands meeting bid specifications

Brand Offered: _____

Model Offered: _____

Warranty Period: _____

**Delivery
(days ARO):** _____

SECTION 6 - BID SPECIFICATIONS – (CONTINUED)

In order to be considered for award, Bidders must fill these Bid Specifications Forms and the Electronic Bid Summary Sheet and submit them with their bid, in time for bid opening.

Item #

33 SAP Number: 6000130

Item Name: SLICER, TWO SPEED AUTOMATIC 12"-13"

Description: ½ HP motor, stainless steel knife. Unit to have completely smooth surface with no cracks or crevices that could harbor food products and no exposed bolt gears or screws. Unit must be NSF approved, U.L. or ETL listed. Microban antimicrobial additive built into the external plastic components to inhibit growth of bacteria and mold. Motor has permanently lubricated ball bearings and is totally enclosed, integral with slicer. Switch shall be moisture protected toggle or touch pad type. Easy to clean, two to four removable parts. Carriage slide rod must be designed to resist rusting and withstand high humidity; electroless nickel coating or equivalent. Stainless steel carriage system tilting and removable without need for tools. Non-removable stainless steel knife ring guard to protect knife during cleaning and operation. No volt interlock release. Top mounted Barazon (or equivalent) knife sharpener that is removable and washable with lifetime guarantee. Knife speed 350-400 RPM. Poly V-Belt or gear driven system, no computers or electronic boards. Electrical 115-120/60/1, maximum 7 amps. Minimum 6 foot, three wire power supply cord and plug.

Bid price must include two-year manufacturer's warranty, parts and labor from date of installation.

Price to also include: Uncrate, set-in-place and demonstration for each order.

Approved Brands: Globe Model 3850N, and Hobart Model HS7N ONLY

Brand Offered: _____

Model Offered: _____

Warranty Period: _____

Delivery (days ARO): _____

SECTION 6 - BID SPECIFICATIONS – (CONTINUED)

In order to be considered for award, Bidders must fill these Bid Specifications Forms and the Electronic Bid Summary Sheet and submit them with their bid, in time for bid opening.

Item #

34 **SAP Number:** *****NEW*****

Item Name: **FOOD PROCESSOR**

Description: Commercial grade food cutter. Continuous feed with automatic start/stop function, single speed 350 rpm, ¾ HP motor. Capacity to process 800-950 lbs./hr. Removable hinged feed hopper lid with magnetic safety lock, dual feed openings with safety pusher, disk ejection system. HD motor with poly-v-belt, polished cast aluminum feed assembly and stainless steel housing. Motor has thermal protection. Food processor can slice, dice, shred, grate and julienne products. Machine base made with stainless steel. Feed assembly made of aluminum. ON/OFF switch is rear mounted and shielded. Approx. dimensions: 23.25"H x 8.5"W x 18.25"D. 115/60/1. Amp draw not to exceed 12.5. To include 6 foot electric cord and plug. To include the following attachments:
SLICER S-5 slicer plate, 3/16", SLICER S-11 slicer plate, 3/8", SHRED-SH7 Shredder 7/16", SLIDER-J2X2 Julienne, DICE-D11 3/8".
Warranty 1-year parts and labor.

Approved Brand: BERKEL M3000-7 Only.

Brand Offered: _____

Model Offered: _____

Warranty Period: _____

Delivery (days ARO): _____

SECTION 6 - BID SPECIFICATIONS – (CONTINUED)

In order to be considered for award, Bidders must fill these Bid Specifications Forms and the Electronic Bid Summary Sheet and submit them with their bid, in time for bid opening.

ITEM 35 – TO BE AWARDED AS A GROUP

Item #

35A SAP Number: 6001082

Item Name: MIXER, 30 QUART

Description: 3/4 H. P. (minimum), electrical 115/60/1 with three wire ground cord and a six foot cord with plug and thermal overload protection. AMP Draw not to exceed 12.0 for 15 AMP Circuit (must not exceed 12 AMPS with cord and NEMA 5-15P). Transmission for unit to be gear driven, constant mesh and internally ventilated or variable speed belt drive. Three fixed speeds; low, intermediate and high. Motor to have permanently lubricated ball bearings and totally enclosed. Bowl-lift to be spring-balanced that locks automatically at top or bottom, adjustable to assure proper clearance between bowl and beater. Unit to be gray powder coat on top of corrosion resistant primer. Floor model, three speed or variable speed, to be equipped with a 15 minute (minimum) timed mixing control which automatically shuts off machine in any speed after set time has elapsed. Stainless steel wire bowl guard. Marked on and off switch. Smooth finish - no hard to clean projections or crevices. Non-Slip rubber or stainless steel feet pads installed to prevent rust. Required Equipment: (1) 30-quart stainless steel bowl, (1) "B" flat beater, (1) "D" wire whip and stainless steel bowl guard or stainless steel screen, cord and plug must be shipped with order and included into the unit price. NSF and U.L. Approved/Listed.
Warranty: Two year manufacturer's warranty, all parts and labor, must be included in the unit price. Inside delivery and set-up required

Approved Brands: Hobart Model HL300, Globe Model SP30 Varimixer V30A ONLY

Brand Offered: _____

Model Offered: _____

Warranty Period: _____
Delivery
(days ARO): _____

Item #

35B SAP Number: 6001083

Item Name: BOWL, STAINLESS STEEL FOR 30 QUART MIXER

Description: Must be compatible and be the same brand as Item 35A.

Approved Brands: Hobart, Globe Varimixer ONLY

Brand Offered: _____

Model Offered: _____

Warranty Period: _____
Delivery
(days ARO): _____

SECTION 6 - BID SPECIFICATIONS – (CONTINUED)

In order to be considered for award, Bidders must fill these Bid Specifications Forms and the Electronic Bid Summary Sheet and submit them with their bid, in time for bid opening.

ITEM 35 – TO BE AWARDED AS A GROUP - CONTINUED

Item #

35C **SAP Number:** **6001084**
Item Name: **BEATER, FLAT “B” FOR 30 QUART MIXER**
Description: Must be compatible and be the same brand as **Item 35A.**

Approved Brands: Hobart, Globe, Varimixer ONLY

Brand Offered: _____

Model Offered: _____

Warranty Period: _____
Delivery
(days ARO): _____

Item #

35D **SAP Number:** **6001085**
Item Name: **HOOK, DOUGH FOR 30 QUART MIXER**
Description: Must be compatible and be the same brand as **Item 35A.**

Approved Brands: Hobart, Globe, Varimixer ONLY

Brand Offered: _____

Model Offered: _____

Warranty Period: _____
Delivery
(days ARO): _____

Item #

35E **SAP Number:** **6001086**
Item Name: **WHIP, “D” WIRE LOOP FOR 30 QUART MIXER**
Description: Must be compatible and be the same brand as **Item 35A.**

Approved Brands: Hobart, Globe, Varimixer ONLY

Brand Offered: _____

Model Offered: _____

Warranty Period: _____
Delivery
(days ARO): _____

SECTION 6 - BID SPECIFICATIONS – (CONTINUED)

In order to be considered for award, Bidders must fill these Bid Specifications Forms and the Electronic Bid Summary Sheet and submit them with their bid, in time for bid opening.

ITEM 35 – TO BE AWARDED AS A GROUP - CONTINUED

Item #

35F SAP Number: 6001087

Item Name: DOLLY, BOWL TRUCK FOR 30 QUART MIXER

Description: Must be compatible and be the same brand as **Item 35A**. Assists in moving bowls from mixer stand. Unit price must include demonstration at school and two year warranty on parts and labor from date of installation at school.

Approved BRRands: Hobart, Globe, Varimixer ONLY

Brand Offered: _____

Model Offered: _____

Warranty Period: _____

**Delivery
(days ARO):** _____

SECTION 6 - BID SPECIFICATIONS – (CONTINUED)

In order to be considered for award, Bidders must fill these Bid Specifications Forms and the Electronic Bid Summary Sheet and submit them with their bid, in time for bid opening.

ITEM 36 – TO BE AWARDED AS A GROUP

Item #

36A SAP Number: 6001088

Item Name: MIXER, 40 QUART

Description: 1-1/2 H.P. or 2 H.P. (minimum), electrical 208/60/1, single phase or 3-phase floor model, three-speed mixer or variable speed with thermal overload protection. Bowl-lift hand operated, self-locking in up or down position with bowl height sensing. Three positive speeds; low, intermediate and high. Gear driven constant mesh transmission or variable speed belt drive. Motor to have permanently lubricated anti-friction ball bearings. Unit to be gray polyurethane enamel or powder coat on top of corrosion resistant primer. To be equipped with a 15 minute (minimum) timed mixing control which automatically shuts off machine in any speed after set time has elapsed. Stainless steel wire bowl guard. Guard lifts or swings to disengage motor. "Start - Stop" push buttons. Smooth finish, no hard to clean projections or crevices. Stainless steel feet or PVC feet pads, or rubber feet installed to prevent rust. Required Equipment: (1) 40-quart stainless steel bowl, (1) "B" flat beater, (1) "D" wire whip, (1) dough hook and stainless steel bowl guard or stainless steel screen, cord and plug must be shipped with order and included into the unit price. NSF and U.L. listed.

Warranty: Two year manufacturer's warranty, all parts and labor, must be included in the unit price. Inside delivery and set-up required

Approved Brands: Hobart Model HL400, Varimixer, or Globe Model SP40 ONLY.

Brand Offered: _____

Model Offered: _____

Warranty Period: _____
Delivery (days ARO): _____

Item #

36B SAP Number: 6001083

Item Name: BOWL, STAINLESS STEEL FOR 40 QUART MIXER

Description: Must be compatible and be the same brand as **Item 36A.**

Approved Brands: Hobart, Varimixer, Globe ONLY.

Brand Offered: _____

Model Offered: _____

Warranty Period: _____
Delivery (days ARO): _____

SECTION 6 - BID SPECIFICATIONS – (CONTINUED)

In order to be considered for award, Bidders must fill these Bid Specifications Forms and the Electronic Bid Summary Sheet and submit them with their bid, in time for bid opening.

ITEM 36 – TO BE AWARDED AS A GROUP - CONTINUED

Item #

36C **SAP Number:** **6001090**
Item Name: **BEATER, FLAT “B” FOR 40 QUART MIXER**
Description: Must be compatible and be the same brand as **Item 36A.**

 Approved Brands: Hobart, Varimixer, Globe ONLY.

Brand Offered: _____
Model Offered: _____
Warranty Period: _____
Delivery
(days ARO): _____

Item #

36D **SAP Number:** **6001092**
Item Name: **HOOK, DOUGH FOR 40 QUART MIXER**
Description: Must be compatible and be the same brand as **Item 36A.**

 Approved Brands: Hobart, Varimixer, Globe ONLY.

Brand Offered: _____
Model Offered: _____
Warranty Period: _____
Delivery
(days ARO): _____

Item #

36E **SAP Number:** **6001091**
Item Name: **WHIP, “D” WIRE LOOP FOR 40 QUART MIXER**
Description: Must be compatible and be the same brand as **Item 36A.**

 Approved Brands: Hobart, Varimixer, Globe ONLY.

Brand Offered: _____
Model Offered: _____
Warranty Period: _____
Delivery
(days ARO): _____

SECTION 6 - BID SPECIFICATIONS – (CONTINUED)

In order to be considered for award, Bidders must fill these Bid Specifications Forms and the Electronic Bid Summary Sheet and submit them with their bid, in time for bid opening.

ITEM 36 – TO BE AWARDED AS A GROUP - CONTINUED

Item #

36F SAP Number: 6004630

Item Name: DOLLY, BOWL TRUCK FOR 40 QUART MIXER

Description: Must be compatible and be the same brand as **Item 36A**. Assists in moving bowls from mixer stand. **Unit price must include demonstration at school and two year warranty on parts and labor from date of installation at school.**

Approved Brands: Hobart, Varimixer, Globe ONLY.

Brand Offered: _____

Model Offered: _____

Warranty Period: _____

**Delivery
(days ARO):** _____

SECTION 6 - BID SPECIFICATIONS – (CONTINUED)

In order to be considered for award, Bidders must fill these Bid Specifications Forms and the Electronic Bid Summary Sheet and submit them with their bid, in time for bid opening.

ITEM 37 – TO BE AWARDED AS A GROUP

Item #

37A SAP Number: 6001094

Item Name: MIXER, 60 QUART

Description: 2.7 H.P. (minimum), electrical (208/60/3 or 1) single phase or three phase, floor model, three to four speed mixer, or variable speed mixer with thermal overload protection. Transmission for unit to be gear driven, constant mesh or variable speed belt drive. Motor to have permanently lubricated ball bearings and totally enclosed motor. Stainless steel wire bowl guard. Guard disengages motor to lift or swing open. Unit to be gray polyurethane enamel on top of corrosion resistant primer. To be equipped with a 15 minute (minimum) timed mixing control which automatically shuts off machine in any speed after set time has elapsed. "Start - Stop" push buttons. Stainless steel feet or PVC feet pads, or rubber feet installed to prevent rust. Smooth finish, no hard to clean projections or crevices. Standard Accessory Package: (1) 60-quart stainless steel bowl, (1) "B" flat beater, (1) "D" wire whip, (1) dough hook and stainless steel bowl guard or stainless steel screen, cord and plug must be shipped with order and be included into the unit price. **NSF and U.L. Approved/Listed. Warranty: Two year manufacturer's warranty, all parts and labor, must be included in the unit price.** Inside delivery and set-up required

Approved Brands: Hobart Model HL-600, Varimixer, Globe Model SP60 ONLY.

Brand Offered: _____

Model Offered: _____

Warranty Period: _____
Delivery
(days ARO): _____

Item #

37B SAP Number: 6001095

Item Name: BOWL, STAINLESS STEEL FOR 60 QUART MIXER

Description: Must be compatible and be the same brand as Item 37A.

Approved Brands: Hobart, Varimixer, Globe ONLY.

Brand Offered: _____

Model Offered: _____

Warranty Period: _____
Delivery
(days ARO): _____

SECTION 6 - BID SPECIFICATIONS – (CONTINUED)

In order to be considered for award, Bidders must fill these Bid Specifications Forms and the Electronic Bid Summary Sheet and submit them with their bid, in time for bid opening.

ITEM 37 – TO BE AWARDED AS A GROUP - CONTINUED

Item #

37F SAP Number: 6001099

Item Name: DOLLY, BOWL TRUCK FOR 60 QUART MIXER

Description: Must be compatible and be the same brand as Item 37A. Assists in moving bowls from mixer stand. **Unit price must include demonstration at school and two year warranty on parts and labor from date of installation at school.**

Approved Brands: Hobart, Varimixer, Globe ONLY.

Brand Offered: _____

Model Offered: _____

Warranty Period: _____

**Delivery
(days ARO):** _____

SECTION 6 - BID SPECIFICATIONS – (CONTINUED)

In order to be considered for award, Bidders must fill these Bid Specifications Forms and the Electronic Bid Summary Sheet and submit them with their bid, in time for bid opening.

Item #

38 SAP Number: 6002181

Item Name: CABINET, NARROW WARMING – DOUBLE COMPARTMENT

Description: Heavy-duty construction with 22 gauge stainless steel exterior casting and two (2) 22 gauge stainless steel doors. Each compartment is separately controlled with their own on/off adjustable thermostats, indicator lights and temperature gauges for inside temperature readings. Approx. dimensions 22"w x 32"d x 75"h. **Width not to exceed 24"**. Include 5" heavy-duty neoprene casters, two swivel, two with brakes. Stainless steel slide racks with capacity for minimum of eight (8) each 18" x 26" sheet pans per cavity. Pan slides to support sheet pan from underside. Maximum amp draw not to exceed 10 amps at 208 Volts, single phase. Total capacity of sixteen (16) 18" x 13" sheet pans per unit (3" spacing).
Warranty: Two year manufacturer's warranty, all parts and labor must be included in the unit price. Price must include inside delivery and complete operational set-up and demonstration.

Approved Brand: Alto-Sham Model 1000-UP ONLY

Brand Offered: _____

Model Offered: _____

Warranty Period: _____

Delivery (days ARO): _____

SECTION 6 - BID SPECIFICATIONS – (CONTINUED)

In order to be considered for award, Bidders must fill these Bid Specifications Forms and the Electronic Bid Summary Sheet and submit them with their bid, in time for bid opening.

Item #

39 SAP Number: 6006180

Item Name: HEATED HOLDING & HUMIDIFIED CABINET – DUTCH DOORS

Description: Fully insulated and welded base frame construction with two doors. 20 gauge stainless steel polished exterior and 22 gauge interior with easy-to-clean coved corners. Welded tubular base frame shall be 1" square, heavy gauge stainless steel tubing, with 10-gauge stainless steel reinforcing stress plate at corners. Insulation to be UG-26 High gauge density fiberglass throughout or fiberglass insulation of .23 K-factor at 75° Fahrenheit. Flush mounted stainless steel insulated doors. High temperature gasket sealed gasket. Each door shall have two heavy-duty edgemounted die cast hinges. Magnetic door latch and positive closing. High and latch mountings reinforced with stainless steel backing plates. Maintenance free tire casters, two rigid and two swivel with brake. Caster plate secured to a 10 gauge stainless steel reinforcing steel plate via welded in place stainless steel studs. Built in humidified holding system to include two separate long life nickel-chromium alloy heating elements per cavity; separate adjustable controls for each function. One control for the interior air temperature and one to control interior air moisture. 12" x 20" stainless steel reservoir shall be removable for ease of cleaning/sanitation. Hi-temp self-lubricated protected fan-cooled blower motor for moist air distribution. Controls shall be up-front recessed and eye-level. Thermostat from 90 to 190°. Welded stainless steel tray slides fully adjustable and removable designed for bottom tray support. Provide 16 pairs of tray/pan slides on 3" spacing. 120 volts single phase. Nema 5-15P 3 wire grounded 10 foot long power cord and plug, side mounted. Amp draw not to exceed 16.0. Front and recessed control panel with separate set, air moisture, and air temperature controls. Maximum dimensions 29" W x 32" D x 73" H. Include 5" heavy-duty neoprene casters, two swivel, two with brakes. Stainless steel wire universal angle racks to support sheet pans or steam table pans from underside with capacity for minimum of eight (8) each 18" x 26" sheet pans per cavity. Built-in humidity system with removable humidity pan. Total capacity of sixteen (16) 18" x 26" sheet pans per unit (3" spacing).
Warranty: Two year manufacturer's warranty, all parts and labor must be included in the unit price. Price must include inside delivery and complete operational set-up and demonstration. Energy Star Approved.

Approved Brand: FWE MTU-12 with Dutch doors ONLY.

Brand Offered: _____

Model Offered: _____

Warranty Period: _____

Delivery (days ARO): _____

SECTION 6 - BID SPECIFICATIONS – (CONTINUED)

In order to be considered for award, Bidders must fill these Bid Specifications Forms and the Electronic Bid Summary Sheet and submit them with their bid, in time for bid opening.

ITEM 40 – TO BE AWARDED AS A GROUP

Item #

40A SAP Number: 6006220

Item Name: BOILERLESS COMBI OVER STEAMER - ELECTRIC

Description: All stainless steel exterior & interior, also top and sides. Unit fully insulated. Precision Humidity Control automatically adjusts after setting temperature. One control knob to control temperature and humidity. Multiple cooking capabilities including baking, steaming, rethermalization, and defrost. Visual recall display of actual temperature and humidity. No pre-programming required. Flashing door lights and audible alarm system to alert user when cooking cycle is finished. Auto-reversing fan with electrical braking system on fan motor. Halogen lighting built into the door. Cool to touch and energy efficient heat reflective tempered glass door. Large LED displays for temperature, time and humidity controls. Standard rack guides with five (5) stainless steel wire racks. Capacity for (7) racks for a total of (7) 18" x 26" pans if needed. Unit to be securely bolted to stainless steel stand w/stainless steel legs.
Unit to include Hallow Carbon Filter system CB30K-System
Electric requirements: Total amp draw not to exceed 55 at 208 v., 3 phase. UL Listed.
Minimum two (2) year parts and labor warranty.
Price to include freight, inside delivery, set in place, Level, remove packing materials, parts manual, factory start-up, factory demonstration.

Approved Brands: Vulcan ABC7E-208 ONLY

Brand Offered: _____

Model Offered: _____

Warranty Period: _____
Delivery (days ARO): _____

Item #

40B SAP Number: 6006221

Item Name: BOILERLESS COMBI OVEN STEAMER – ELECTRIC 480V

Description: Same as 40A above except 480 v., 3 phase.

Brand Offered: _____

Model Offered: _____

Warranty Period: _____
Delivery (days ARO): _____

SECTION 6 - BID SPECIFICATIONS – (CONTINUED)

In order to be considered for award, Bidders must fill these Bid Specifications Forms and the Electronic Bid Summary Sheet and submit them with their bid, in time for bid opening.

ITEM 41 – TO BE AWARDED AS A GROUP

Item #

41A **SAP Number:** **6000808**
Item Name: **AUTOMATIC ICE MAKING MACHINE, 249 LBS. MINIMUM**
Description: Modular air cooled ice maker, ARI standard minimum of 249 lbs. at 90° air and 70° water. Medium ice cube size – 7/8" x 7/8" x 7/8". Corrosion-resistant stainless steel exterior. No air filter or front located air filter. 115/60/1 electric requirements only. Max. fuse size 15 amps. Unit to be 22" wide. Air cooled. Complete with factory approved water filter.
WARRANTY: 3 year parts and labor on all components; 5-7 year parts & labor on evaporator; 5 year parts on compressor, condenser.
Note: Unit price shall include installation, set up, placement, shipping, free warranty service calls while machine under warranty, start-up, parts manual. SBBC shall supply existing water line, electric outlets, and drainage.
MUST BE ENERGY STAR RATED
Approved Brands:
Scotsman C0332SA-1A, Manitowac ID-0322A, Hoshizaki KM-340 MAH ONLY.

Brand Offered: _____
Model Offered: _____
Warranty Period: _____
Delivery (days ARO): _____

Item #

41B **SAP Number:** **6000805**
Item Name: **BIN – 360 LBS. MINIMUM**
Description: Holds minimum 360 lbs. To be compatible with Item A. To have minimum storage capacity of 360 lbs. Front door and sides of bin to be stainless steel or polyethylene exterior. 6" adjustable legs. Foamed-in-place polyurethane insulation. Non-corosive polyliner. NSF and UL listed.
WARRANTY: 3 year parts and labor.

Approved Brands:
Scotsman B322S, Hoshizaki B-300SF, Manitowac B-320 ONLY

Brand Offered: _____
Model Offered: _____
Warranty Period: _____
Delivery (days ARO): _____

SECTION 6 - BID SPECIFICATIONS – (CONTINUED)

In order to be considered for award, Bidders must fill these Bid Specifications Forms and the Electronic Bid Summary Sheet and submit them with their bid, in time for bid opening.

ITEM 42 – TO BE AWARDED AS A GROUP

Item #

42A SAP Number: 6000803

Item Name: AUTOMATIC ICE MAKING MACHINE, 368 LBS. MINIMUM

Description: (330 lbs.) Modular air cooled ice maker, ARI standard minimum of 368 lbs. at 90° air and 70° water. Medium ice cube size – 7/8" x 7/8" x 7/8". Corrosion-resistant stainless steel exterior. No air filter or front located air filter. 115/60/1 electric requirements only. 30" wide. Air cooled. Complete with factory approved water filter. **WARRANTY:** 3 year parts and labor on all components; 5-7 year parts & labor on evaporator; 5 year parts on compressor, condenser.

Note: Unit price shall include installation, set up, placement, shipping, free warranty service calls while machine under warranty, start-up, parts manual. SBBC shall supply existing water line, electric outlets, and drainage.

MUST BE ENERGY STAR RATED

Approved Brands:

Scotsman C0530SA-1A, Manitowac ID0502-A, Ice-O-Matic ICE0400A, Hoshizaki KM-515MAH ONLY.

Brand Offered: _____

Model Offered: _____

Warranty Period: _____
Delivery (days ARO): _____

Item #

42B SAP Number: 6000804

Item Name: BIN, 500 LBS. MINIMUM

Description: To be compatible with Item A. Holds minimum 500 lbs. Front door and sides of bin to be stainless steel or polyethylene exterior. 6" adjustable legs. Foamed-in-place polyurethane insulation. Non-corrosive polyliner. NSF and UL listed. **WARRANTY:** 3 year parts and labor.

Approved Brands:

Scotsman B530P, Ice-O-Matic B42, Hoshizaki B-500 SF, Manitowac B-570 ONLY

Brand Offered: _____

Model Offered: _____

Warranty Period: _____
Delivery (days ARO): _____

SECTION 6 - BID SPECIFICATIONS – (CONTINUED)

In order to be considered for award, Bidders must fill these Bid Specifications Forms and the Electronic Bid Summary Sheet and submit them with their bid, in time for bid opening.

ITEM 43 – TO BE AWARDED AS A GROUP

Note: Item group 43 are Serving Line pieces intended for Elementary Schools. All items in this group will have approx. 27" high tray slides, approx. 29" high utility counters and cold tables with the height on the hot well units and cashier stands raised to approx. 35" high. All utility counters and hot tables will have a single tier sneeze guard, all cold tables will have a double tier sneeze guard. Hot table must include J-Box in base easily accessible to electricians and to include access cut-out or open space in bottom of base. Cashier stands must include a shelf approx. 16" aff. Colors of units must match color selection provided by Broward County Food & Nutrition Services Dept. Installation includes cleaning of units, precision lined up tray slides and distance from the wall which will be approx. 38" – 48". Warranty shall be full two (2) year parts and labor, and full three (3) year parts and labor warranty of tray slides.

Item #

43A SAP Number: 6006204

Item Name: HOT WELL

Description: 60" x 34" x 35" unit. To include; four (4) individually controlled wells, counter protector with stainless steel top, 14 gauge stainless steel server work board, flat tray slide, modified counter and tray slide height per plan. Construction to be one piece of die-formed 14 gauge stainless steel with 1 1/2", 900 nosing on all sides. 12" x 20" top openings with raised die-stamped perimeters. Body frame to be all welded construction of steel with exposed corners to be 1 1/4" stainless steel. All corners welded and polished. Body ends and panels to be plastic laminate with galvanized steel backing (specify laminate color). Body ends and panels to be removable to allow the changing of colors. Unit to be equipped with 4 adjustable legs that are recessed inside of toe area. Unit shipped with 8'- cord & plug installed. Unit comes standard with thermostatic controls. Each controls has a lighted on/off switch that allows turning off of each well. Controls and elements mounted behind removable front panel for easy access to changing elements, element boxes or controls through easy to remove access panel. Individual food wells wired to common junction box(es). Each unit supplied with UL listed power cord. Concealed locking mechanism with easy to use spring-activated catch. 208/240/60/1 22amps.

Approved Brands: Randell Model # RAN HTD-4S, Low Temp or Delfield ONLY

Brand Offered: _____

Model Offered: _____

Warranty Period: _____

Delivery (days ARO): _____

SECTION 6 - BID SPECIFICATIONS – (CONTINUED)

In order to be considered for award, Bidders must fill these Bid Specifications Forms and the Electronic Bid Summary Sheet and submit them with their bid, in time for bid opening.

ITEM 43 – TO BE AWARDED AS A GROUP - CONTINUED

Item #

43B SAP Number: 6006205

Item Name: UTILITY COUNTER 72" x 34" x 31"

Description: 72" x 34" x 31" unit. To include; 1ea. single tier deck mounted overself 18" deep with 60" heat lamp mounted as shown on plan, adjustable food guard, flat tray slide, modified counter and tray slide height per plan. Construction; top to be one piece of die-formed 14 gauge stainless steel with 1 ½", 900 nosing on all sides. Body frame to be all welded construction of steel with exposed corners to be 1 ½" stainless steel. All corners welded and polished. Body ends and panels to be plastic laminate with galvanized steel backing (specify laminate color). Body ends and panels to be removable to allow the changing of colors. Unit provided with a stainless steel work surface. Unit to be equipped with 4 adjustable legs that are recessed inside of toe area. Concealed locking mechanism with easy to use spring-activated catch.

Approved Brand: Randell Model # RAN UTILITY M-72, Low Temp or Delfield ONLY

Brand Offered: _____

Model Offered: _____

Warranty Period: _____

**Delivery
(days ARO):** _____

SECTION 6 - BID SPECIFICATIONS – (CONTINUED)

In order to be considered for award, Bidders must fill these Bid Specifications Forms and the Electronic Bid Summary Sheet and submit them with their bid, in time for bid opening.

ITEM 43 – TO BE AWARDED AS A GROUP - CONTINUED

Item #

43C **SAP Number:** **6006206**
Item Name: **ICE COLD PAN 60" x 34" x 31"**
Description: 60" x 34" x 31" unit. To include; 1ea. double tier deck mounted overshelf 18" deep with adjustable food guards, flat tray slide, perforated pan insert, modified cold pan depth per plan, modified counter and tray slide height per plan. Construction; top to be one piece of die-formed 14 gauge stainless steel with 1 ½", 900 nosing on all sides. Unit fitted with 6" deep, ice cooled display cold pan. Interior of pan to be one piece, continuously welded construction of 18 gauge stainless steel. Interior fitted with 1" drain at one end. Drain nipple supplied with ball valve and lever extension to cabinet exterior on enclosed base units- drain lines run to accessible area. 1" high perforated, stainless steel bottom strainer plates provided. Body frame to be all welded construction of steel with exposed corners to be 1 ½" stainless steel. All corners welded and polished. Body ends and panels to be plastic laminate with galvanized steel backing (specify laminate color). Body ends and panels to be removable to allow the changing of colors. Cold pan insulated with high density (CFC free) polyurethane, foamed in place. Unit to be equipped with 4 adjustable legs that are recessed inside of toe area. Concealed locking mechanism with easy to use spring-activated catch.
Approved Brand: Randell Model # RAN COLD M-60, Low Temp or Delfield ONLY

Brand Offered: _____

Model Offered: _____

Warranty Period: _____
Delivery
(days ARO): _____

Item #

43D **SAP Number:** **6006207**
Item Name: **CASHIER STAND 48" x 34" x 35"**
Description: 48" x 34" x 35" unit. To include; flat tray slide, ferruled utility drop dimension per plan, modified counter and tray slide height per plan. Construction; top to be one piece of die-formed 14 gauge stainless steel with 1 ½", 900 nosing on all sides. Body frame to be all welded construction of steel with exposed corners to be 1 ½" stainless steel. All corners welded and polished. Body ends and panels to be plastic laminate with galvanized steel backing (specify laminate color). Body ends and panels to be removable to allow the changing of colors. Unit provided with a stainless steel work surface. Unit to be equipped with 4 adjustable legs that are recessed inside of toe area. Concealed locking mechanism with easy to use spring-activated catch
Approved Brand: Randell Model # RAN CAM-48, Low Temp or Delfield ONLY

Brand Offered: _____

Model Offered: _____

Warranty Period: _____
Delivery
(days ARO): _____

SECTION 6 - BID SPECIFICATIONS – (CONTINUED)

In order to be considered for award, Bidders must fill these Bid Specifications Forms and the Electronic Bid Summary Sheet and submit them with their bid, in time for bid opening.

ITEM 43 – TO BE AWARDED AS A GROUP - CONTINUED

Item #

43E SAP Number: 6006208

Item Name: CASHIER STAND 40" x 34" x 35"

Description: 40" x 34" x 35" unit. To include; flat tray slide, ferruled utility drop dimension per plan, modified counter and tray slide height per plan. Construction; top to be one piece of die-formed 14 gauge stainless steel with 1 1/2", 900 nosing on all sides. Body frame to be all welded construction of steel with exposed corners to be 1 1/2" stainless steel. All corners welded and polished. Body ends and panels to be plastic laminate with galvanized steel backing (specify laminate color). Body ends and panels to be removable to allow the changing of colors. Unit provided with a stainless steel work surface. Unit to be equipped with 4 adjustable legs that are recessed inside of toe area. Concealed locking mechanism with easy to use spring-activated catch.

Approved Brands: Randell Model # RAN CAM-40, Low Temp or Delfield ONLY

Brand Offered: _____

Model Offered: _____

Warranty Period: _____
Delivery (days ARO): _____

Item #

43F SAP Number: ###NEW###

Item Name: UTILITY COUNTER 66" x 34" x 31"

Description: 66" x 34" x 31" unit. To include; 1ea. single tier deck mounted overself 18" deep with 60" heat lamp mounted as shown on plan, adjustable food guard, flat tray slide, modified counter and tray slide height per plan. Construction; top to be one piece of die-formed 14 gauge stainless steel with 1 1/2", 900 nosing on all sides. Body frame to be all welded construction of steel with exposed corners to be 1 1/2" stainless steel. All corners welded and polished. Body ends and panels to be plastic laminate with galvanized steel backing (specify laminate color). Body ends and panels to be removable to allow the changing of colors. Unit provided with a stainless steel work surface. Unit to be equipped with 4 adjustable legs that are recessed inside of toe area. Concealed locking mechanism with easy to use spring-activated catch.

Approved Brands: Randell Model # RAN Utility M-66, Low Temp, or Delfield ONLY

Brand Offered: _____

Model Offered: _____

Warranty Period: _____
Delivery (days ARO): _____

SECTION 6 - BID SPECIFICATIONS – (CONTINUED)

In order to be considered for award, Bidders must fill these Bid Specifications Forms and the Electronic Bid Summary Sheet and submit them with their bid, in time for bid opening.

ITEM 43 – TO BE AWARDED AS A GROUP - CONTINUED

Item #

43G **SAP Number:** **###NEW###**
Item Name: **UTILITY COUNTER 60" x 34" x 31"**
Description: 60" x 34" x 31" unit. To include; 1ea. single tier deck mounted over shelf 18"deep with 54" heat lamp mounted as shown on plan, adjustable food guard, flat tray slide, modified counter and tray slide height per plan. Construction; top to be one piece of die-formed 14 gauge stainless steel with 1 1/2", 900 nosing on all sides. Body frame to be all welded construction of steel with exposed corners to be 1 1/2" stainless steel. All corners welded and polished. Body ends and panels to be plastic laminate with galvanized steel backing (specify laminate color). Body ends and panels to be removable to allow the changing of colors. Unit provided with a stainless steel work surface. Unit to be equipped with 4 adjustable legs that are recessed inside of toe area. Concealed locking mechanism with easy to use spring-activated catch.

Approved Brands: Randell Model # RAN Utility M-60, Low Temp, or Delfield ONLY.

Brand Offered: _____
Model Offered: _____
Warranty Period: _____
Delivery (days ARO): _____

Item #

43H **SAP Number:** **###NEW###**
Item Name: **UTILITY COUNTER 54" x 34" x 31"**
Description: 54" x 34" x 31" unit. To include; 1ea. single tier deck mounted overshelf 18"deep with 48" heat lamp mounted as shown on plan, adjustable food guard, flat tray slide, modified counter and tray slide height per plan. Construction; top to be one piece of die-formed 14 gauge stainless steel with 1 1/2", 900 nosing on all sides. Body frame to be all welded construction of steel with exposed corners to be 1 1/2" stainless steel. All corners welded and polished. Body ends and panels to be plastic laminate with galvanized steel backing (specify laminate color). Body ends and panels to be removable to allow the changing of colors. Unit provided with a stainless steel work surface. Unit to be equipped with 4 adjustable legs that are recessed inside of toe area. Concealed locking mechanism with easy to use spring-activated catch.

Approved Brands: Randell Model # RAN Utility M-54, Low Temp, or Delfield ONLY

Brand Offered: _____
Model Offered: _____
Warranty Period: _____
Delivery (days ARO): _____

SECTION 6 - BID SPECIFICATIONS – (CONTINUED)

In order to be considered for award, Bidders must fill these Bid Specifications Forms and the Electronic Bid Summary Sheet and submit them with their bid, in time for bid opening.

ITEM 43 – TO BE AWARDED AS A GROUP - CONTINUED

Item #

43 I **SAP Number:** **###NEW###**

Item Name: **ICE COLD PAN 80" x 34" x 31"**

Description: 80" x 34" x 31" unit. To include; 1ea. double tier deck mounted oversheff 18" deep with adjustable food guards, flat tray slide, perforated pan insert, modified cold pan depth per plan, modified counter and tray slide height per plan. Construction; top to be one piece of die-formed 14 gauge stainless steel with 1 ½", 900 nosing on all sides. Unit fitted with 6" deep, ice cooled display cold pan. Interior of pan to be one piece, continuously welded construction of 18 gauge stainless steel. Interior fitted with 1" drain at one end. Drain nipple supplied with ball valve and lever extension to cabinet exterior on enclosed base units- drain lines run to accessible area. 1" high perforated, stainless steel bottom strainer plates provided. Body frame to be all welded construction of steel with exposed corners to be 1 ½" stainless steel. All corners welded and polished. Body ends and panels to be plastic laminate with galvanized steel backing (specify laminate color). Body ends and panels to be removable to allow the changing of colors. Cold pan insulated with high density (CFC free) polyurethane, foamed in place. Unit to be equipped with 4 adjustable legs that are recessed inside of toe area. Concealed locking mechanism with easy to use spring-activated catch.

Approved Brands: Randell Model # RAN Cold M-80, Low Temp, or Delfield ONLY.

Brand Offered: _____

Model Offered: _____

Warranty Period: _____

Delivery (days ARO): _____

SECTION 6 - BID SPECIFICATIONS – (CONTINUED)

In order to be considered for award, Bidders must fill these Bid Specifications Forms and the Electronic Bid Summary Sheet and submit them with their bid, in time for bid opening.

ITEM 43 – TO BE AWARDED AS A GROUP - CONTINUED

Item #

43J **SAP Number:** **###NEW###**
Item Name: **CASHIER STAND 36" x 34" x 35"**
Description: 36" x 34" x 35" unit. To include; flat tray slide, ferruled utility drop dimension per plan, modified counter and tray slide height per plan. Construction; top to be one piece of die-formed 14 gauge stainless steel with 1 ½", 900 nosing on all sides. Body frame to be all welded construction of steel with exposed corners to be 1 ½" stainless steel. All corners welded and polished. Body ends and panels to be plastic laminate with galvanized steel backing (specify laminate color). Body ends and panels to be removable to allow the changing of colors. Unit provided with a stainless steel work surface. Unit to be equipped with 4 adjustable legs that are recessed inside of toe area. Concealed locking mechanism with easy to use spring-activated catch.

Approved Brands: Randell Model # RAN CAM-36, Low Temp, or Delfield ONLY.

Brand Offered: _____

Model Offered: _____

Warranty Period: _____

Delivery (days ARO): _____

Item #

43K **SAP Number:** **###NEW###**
Item Name: **UTILITY COUNTER 50" x 34" x 31"**
Description: 50" x 34" x 31" unit. To include; 1ea. single tier deck mounted overself 18" deep with 48" heat lamp mounted as shown on plan, adjustable food guard, flat tray slide, modified counter and tray slide height per plan. Construction; top to be one piece of die-formed 14 gauge stainless steel with 1 ½", 900 nosing on all sides. Body frame to be all welded construction of steel with exposed corners to be 1 ½" stainless steel. All corners welded and polished. Body ends and panels to be plastic laminate with galvanized steel backing (specify laminate color). Body ends and panels to be removable to allow the changing of colors. Unit provided with a stainless steel work surface. Unit to be equipped with 4 adjustable legs that are recessed inside of toe area. Concealed locking mechanism with easy to use spring-activated catch.

Approved Brands: Randell Model # RAN Utility M-50, Low Temp, or Delfield ONLY.

Brand Offered: _____

Model Offered: _____

Warranty Period: _____

Delivery (days ARO): _____

SECTION 6 - BID SPECIFICATIONS – (CONTINUED)

In order to be considered for award, Bidders must fill these Bid Specifications Forms and the Electronic Bid Summary Sheet and submit them with their bid, in time for bid opening.

ITEM 44 – TO BE AWARDED AS A GROUP

Item #

44A SAP Number: 6006183

Item Name: 5' COOK'S TABLE W/POT RACK

Description: See Illustration 44A / 44B.

Note: For all custom made cook's tables, a complete drawing, illustrating the following information, but not limited to dimensions, sizes, types of materials, and accessories, must be furnished for evaluation purposes. Failure to furnish complete drawing will result in disqualification of bid item.

To be 60" long x 30" wide x 36" high. To be constructed of 14 gauge series 300 stainless steel, under shelf to be 10" off floor and constructed of 16 gauge series 300 stainless steel. Top and undershelf to have rounded corners; no backsplash. Stainless steel tubular legs with adjustable flanges bullet feet.

Complete with stainless steel drawer, stainless steel pot rack, utensil rack and overshelf. Drawer 20"-22" x 20" x 5", removable, set into stainless steel frame with roller ball bearing slides. Pot rack to be of semi-circular design approx. 60" long, furnished with 1-5/8" diameter 12 gauge tubular stainless steel supports extending through overshelf and tabletop and fastened securely to undershelf. Top of pot rack to be four (4) feet above table. Pot rack (table-mounted, rear or splash mounted) must include a minimum of eighteen pothooks. Utensil rack to have a minimum of 9 hooks. Overshelf included is to be constructed of 15-gauge stainless steel approximately 18" above tabletop and 24" below top of pan rack. Overshelf to be 60" long x 10" wide with stainless steel uprights of shelf, rear mounted. Also furnish pan rack with stainless steel crossbar approximately 10" below the top. Rear mounting provision.

Unit price to include freight, inside delivery, complete assembly & set in place at school.

Approved Brands: Advance Tabco, Duke, Universal Stainless, or SPG International, ONLY

Brand Offered: _____

Model Offered: _____

Warranty Period: _____

Delivery (days ARO): _____

SECTION 6 - BID SPECIFICATIONS – (CONTINUED)

In order to be considered for award, Bidders must fill these Bid Specifications Forms and the Electronic Bid Summary Sheet and submit them with their bid, in time for bid opening.

ITEM 44 – TO BE AWARDED AS A GROUP - CONTINUED

Item #

44B SAP Number: 6006184
Item Name: 6' COOK'S TABLE W/POT RACK
Description: See Illustration 44A / 44B.

Note: For all custom made cook's tables, a complete drawing, illustrating the following information, but not limited to dimensions, sizes, types of materials, and accessories, must be furnished for evaluation purposes. Failure to furnish complete drawing will result in disqualification of bid item.

To be 72" long x 30" wide x 36" high. To be constructed of 14 gauge series 300 stainless steel, undershelf to be 10" off floor and constructed of 16 gauge series 300 stainless steel. Top and undershelf to have rounded corners; no backsplash. Stainless steel tubular with adjustable flanges bullet feet.

Complete with stainless steel drawer, stainless steel pot rack, utensil rack and overshelf. Drawer 20"-22" x 20" x 5", removable, set into stainless steel frame with roller ball bearing slides. Pot rack to be of semi-circular design approx. 72" long, furnished with 1-5/8" diameter 12 gauge tubular stainless steel supports extending through overshelf and tabletop and fastened securely to undershelf. Top of pot rack to be four (4) feet above table. Pot rack (table-mounted, rear or splash mounted) must include a minimum of eighteen pothooks. Utensil rack to have a minimum of 9 hooks. The overshelf is to be constructed of 15-gauge stainless steel approximately 18" above tabletop and 24" below top of pot rack. Overshelf to be 72" long x 10" wide with stainless steel upright of shelf, rear mounted. Also furnish pan rack with stainless steel crossbar approximately 10" below the top. Rear mounting provision.

Unit price to include freight, inside delivery, complete assembly & set in place at school.

Approved Brands: Advance Tabco, Duke, Universal Stainless, or SPG International ONLY

Brand Offered: _____

Model Offered: _____

Warranty Period: _____

Delivery (days ARO): _____

SECTION 6 - BID SPECIFICATIONS – (CONTINUED)

In order to be considered for award, Bidders must fill these Bid Specifications Forms and the Electronic Bid Summary Sheet and submit them with their bid, in time for bid opening.

Item #

45 SAP Number: SAP# 6006261

**Item Name: CONVECTION STEAMER, TWO COMPARTMENT ELECTRIC STEAM GENERATOR.
6 PAN CAPACITY**

Description: Stainless steel pressure-less steamer with two twin atmospheric electric independent. Steam generators rated at a minimum of 9.0 KW each complete with electric low water cut-off. Heat up time to be minimum of ten minutes or less from a cold start. Unit shall allow operator to delime both steam generators through access port in each cavity without tools or service call from service agency.

Cavities and cabinet base stainless steel construction. Doors to be stainless steel, insulated, and provided with one-piece replaceable seal. Doors to have hidden magnetic door switch cutting power to blower and reducing power to generator when door is opened. 60 minute mechanical timer. Unit to include "Ready" or equivalent indicator light. Complete with automatic blow down when unit is turned off. Capacity for six 12" x 20" x 2-1/2" deep pans. Four stainless steel legs with level adjustment. Controls easily accessible from front or sides. Dual cold water connection provided so that steam generator is on a separate line from condenser.

National Sanitation Foundation (NSF) and Underwriter's Laboratories (UL) approved Note to installers: Plumbing requirements: Unit requires two 3/4" or 3/8" IPS cold water supply lines, 1-1/2" O.D. free venting drain. A second cold water connection is also provided for spray condenser.

Filter: Complete with Everpure Filter Model EV9797-22 Kleen Steam II Twin Filter System. Provide 2 ea. 4FC5 (EV9693-21) filters installed in system in lieu of 2 each EV9618-16 that comes standard with the system.

Electrical requirements: **Unit requires 480V, three phase.** Unit must fit on existing 60 amp breaker in schools. **Warranty: Two year manufacturer's warranty, all parts and labor must be included in the unit price.**

Installation: Unit price must include inside delivery, uncrating, set in place, remove cartons and tape, installation of shelves and accessories, level, factory start up, disposal of packaging materials and training. Service manuals, parts lists and wiring diagrams must accompany each delivered unit. Final electrical, plumbing and gas connections will be done by SBBC Personnel.

Approved Brand: Groen Hyper Steam Model HY-6E, ONLY

Brand Offered: _____

Model Offered: _____

Warranty Period: _____

Delivery (days ARO): _____

SECTION 6 - BID SPECIFICATIONS – (CONTINUED)

In order to be considered for award, Bidders must fill these Bid Specifications Forms and the Electronic Bid Summary Sheet and submit them with their bid, in time for bid opening.

ITEM 46 – TO BE AWARDED AS A GROUP

Item #

46A SAP Number: SAP #6006251

Item Name: COMBITHERM, CTP7-20E, ELECTRIC 208V

Description: Alto-Shaam Combitherm® CT PROformance™ counter-top model CTP7-20E electric Combi-Oven with self-contained boiler, designed with EcoSmart® technology for reduced energy and water consumption. Includes operational modes for steam, convection, a combination of steam and convection heat, and retherm. Oven is to be constructed of 18 gauge stainless steel interior cavity. Oven includes an attached retractable hand shower spray hose with safety shutoff interlock system and a backflow preventer. PROtouch™ control features includes a cool-down function, automatic cleaning function, recipe programming, two power levels, 0-100% humidity levels, auto-reversing fan with five (5) fan speeds, multi-shelf timers, and sleep mode. Oven includes USB port, HACCP data access, and four (4) adjustable stainless steel legs. Each oven is to accommodate up to seven (7) full-size sheet pans or fourteen (14) full-size hotel pans (GN 1/1), include standard right-hand door hinging, seven (7) non-tilt support rails, and four (4) stainless steel shelves. Oven to be provided with Cool Touch 3 triple pane window door with hinged inner glass to prevent additional heat loss and increase safety and cooking efficiency.

Stand: 5016084 Combitermo Combioven stand, stationary with pan slides and shelf.

Interior Dimensions: (HxWxD) 23-1/4" x 24-1/4" x 32-3/4" (590mm x 616mm x 832mm);

Exterior Dimensions: (HxWxD) 37-13/16" x 43-3/4" x 46-3/16" (961mm x 1111mm x 1173mm)

Water Requirements: ONE (1) TREATED WATER INLET: 3/4" NPT* ONE (1) UNTREATED WATER INLET: 3/4" NPT* LINE PRESSURE: 30 to 90 psi 2.1 to 6.3 bar

Water Drain: 1-1/2" (40mm) CONNECTION WITH A 2" (51mm) MINIMUM AIR GAP INSTALLED AS CLOSE TO THE OVEN AS POSSIBLE. MATERIALS MUST WITHSTAND TEMPERATURES UP TO 200°F (93°C). Can Manifold off of one ¾" line.

Filter: Complete with Optipure QTI – 1 Filtration System 2 each

Electrical Requirements: (NO CORD, NO PLUG, DEDICATED CIRCUIT REQUIRED) DO NOT CONNECT TO A G.F.I. OUTLET: **208-240V/50/60/3-ph**, 45.7-52.7 amps, 16.5-21.9kw, 4-3 AWG

Warranty: Two year manufacturer's warranty, all parts and labor must be included in the unit price. Installation: Unit price must include inside delivery, uncrating, set in place, remove cartons and tape, installation of shelves and accessories, level, factory start up, disposal of packaging materials and training. Service manuals, parts lists and wiring diagrams must accompany each delivered unit. Final electrical, plumbing and gas connections will be done by SBBC Personnel.

Approved Brand: Alto-Sham Model CTP7-20E only.

Brand Offered: _____

Model Offered: _____

Warranty Period: _____

Delivery (days ARO): _____

SECTION 6 - BID SPECIFICATIONS – (CONTINUED)

In order to be considered for award, Bidders must fill these Bid Specifications Forms and the Electronic Bid Summary Sheet and submit them with their bid, in time for bid opening.

ITEM 46 – TO BE AWARDED AS A GROUP - CONTINUED

Item #

46B SAP Number: SAP #6006252

Item Name: COMBITHERM, CTP7-20E, ELECTRIC 480V

Description: Alto-Shaam Combitherm® CT PROformance™ counter-top model CTP7-20E electric Combi-Oven with self-contained boiler, designed with EcoSmart® technology for reduced energy and water consumption. Includes operational modes for steam, convection, a combination of steam and convection heat, and retherm. Oven is to be constructed of 18 gauge stainless steel interior cavity. Oven includes an attached retractable hand shower spray hose with safety shutoff interlock system and a backflow preventer. PROtouch™ control features includes a cool-down function, automatic cleaning function, recipe programming, two power levels, 0-100% humidity levels, auto-reversing fan with five (5) fan speeds, multi-shelf timers, and sleep mode. Oven includes USB port, HACCP data access, and four (4) adjustable stainless steel legs. Each oven is to accommodate up to seven (7) full-size sheet pans or fourteen (14) full-size hotel pans (GN 1/1), include standard right-hand door hinging, seven (7) non-tilt support rails, and four (4) stainless steel shelves. Oven to be provided with Cool Touch 3 triple pane window door with hinged inner glass to prevent additional heat loss and increase safety and cooking efficiency.

Stand: 5016084 Combi Thermo Combi Oven Stand, stationary with pan slides and shelf.

Interior Dimensions: (HxWxD) 23-1/4" x 24-1/4" x 32-3/4" (590mm x 616mm x 832mm);

Exterior Dimensions: (HxWxD) 37-13/16" x 43-3/4" x 46-3/16" (961mm x 1111mm x 1173mm)

Water Requirements: ONE (1) TREATED WATER INLET: 3/4" NPT* ONE (1) UNTREATED WATER INLET: 3/4" NPT* LINE PRESSURE: 30 to 90 psi 2.1 to 6.3 bar

Water Drain: 1-1/2" (40mm) CONNECTION WITH A 2" (51mm) MINIMUM AIR GAP INSTALLED AS CLOSE TO THE OVEN AS POSSIBLE. MATERIALS MUST WITHSTAND TEMPERATURES UP TO 200°F (93°C). Can Manifold off of one ¾" line.

Filter: Complete with Optipure QTI-1 Filtration System 2 each

Electrical Requirements: (NO CORD, NO PLUG, DEDICATED CIRCUIT REQUIRED) DO NOT CONNECT TO A G.F.I. OUTLET: 480V/3-ph, 45.7-52.7 amps, 16.5-21.9kw, 4-3 AWG

Warranty: Two year manufacturer's warranty, all parts and labor must be included in the unit price. Installation: Unit price must include inside delivery, uncrating, set in place, remove cartons and tape, installation of shelves and accessories, level, factory start up, disposal of packaging materials and training. Service manuals, parts lists and wiring diagrams must accompany each delivered unit. Final electrical, plumbing and gas connections will be done by SBBC Personnel.

Approved Brand: Alto-Sham Model CTP7-20E only.

Brand Offered: _____

Model Offered: _____

Warranty Period: _____

Delivery (days ARO): _____

SECTION 6 - BID SPECIFICATIONS – (CONTINUED)

In order to be considered for award, Bidders must fill these Bid Specifications Forms and the Electronic Bid Summary Sheet and submit them with their bid, in time for bid opening.

ITEM 46 – TO BE AWARDED AS A GROUP - CONTINUED

Item #

46C SAP Number: SAP #6006253

Item Name: COMBITHERM, CTP10-20E, ELECTRIC, FULL SIZE 208V

Description: Alto-Shaam Combitherm® CT PROformance™ counter-top model CTP10-20E electric Combi-Oven with self-contained boiler, designed with EcoSmart® technology for reduced energy and water consumption. Includes operational modes for steam, convection, a combination of steam and convection heat, and retherm. Oven is to be constructed of 18 gauge stainless steel interior cavity. Oven includes an attached retractable hand shower spray hose with safety shutoff interlock system and a backflow preventer. PROtouch™ control features includes a cool-down function, automatic cleaning function, recipe programming, two power levels, 0-100% humidity levels, auto-reversing fan with five (5) fan speeds, multi-shelf timers, and sleep mode. Oven includes USB port, HACCP data access, and four (4) adjustable stainless steel legs. Each oven is to accommodate up to ten (10) full-size sheet pans or twenty (20) full-size hotel pans (GN 1/1), include standard right-hand door hinging, ten (10) non-tilt support rails, and six (6) stainless steel shelves. Oven to be provided with Cool Touch 3 triple pane window door with hinged inner glass to prevent additional heat loss and increase safety and cooking efficiency.

Stand: 5016084 Combitherm Combi Oven Stand, stationary with pan slides and shelf.

Interior Dimensions: (HxWxD) 31-1/2" x 24-1/4" x 32-3/4" (800mm x 616mm x 832mm);

Exterior Dimensions: (HxWxD) 45-11/16" x 43-3/4" x 46-3/16" (1160mm x 1111mm x 1173mm)

Water Requirements: ONE (1) TREATED WATER INLET: 3/4" NPT* ONE (1) UNTREATED WATER INLET: 3/4" NPT* LINE PRESSURE: 30 to 90 psi 2.1 to 6.3 bar

Water Drain: 1-1/2" (40mm) CONNECTION WITH A 2" (51mm) MINIMUM AIR GAP INSTALLED AS CLOSE TO THE OVEN AS POSSIBLE. MATERIALS MUST WITHSTAND TEMPERATURES UP TO 200°F (93°C). Can Manifold off of one 3/4" line.

Filter: Complete with Optipure QTI-1 Filtration System 2 each

Electrical Requirements: (NO CORD, NO PLUG, DEDICATED CIRCUIT REQUIRED) DO NOT CONNECT TO A G.F.I. OUTLET: 208-240V/50/60/3-ph, 68.8-79.4 amps, 24.8-33kw, 2-1AWG

Warranty: Two year manufacturer's warranty, all parts and labor must be included in the unit price. Installation: Unit price must include inside delivery, uncrating, set in place, remove cartons and tape, installation of shelves and accessories, level, factory start up, disposal of packaging materials and training. Service manuals, parts lists and wiring diagrams must accompany each delivered unit. Final electrical, plumbing and gas connections will be done by SBBC Personnel.

Approved Brand: Alto-Sham Model CTP10-20E only.

Brand Offered: _____

Model Offered: _____

Warranty Period: _____

Delivery (days ARO): _____

SECTION 6 - BID SPECIFICATIONS – (CONTINUED)

In order to be considered for award, Bidders must fill these Bid Specifications Forms and the Electronic Bid Summary Sheet and submit them with their bid, in time for bid opening.

ITEM 46 – TO BE AWARDED AS A GROUP - CONTINUED

Item #

46D SAP Number: SAP #6006254

Item Name: COMBITHERM, CTP10-20E, ELECTRIC, FULL SIZE 480V

Description: Alto-Shaam Combitherm® CT PROformance™ counter-top model CTP10-20E electric Combi-Oven with self-contained boiler, designed with EcoSmart® technology for reduced energy and water consumption. Includes operational modes for steam, convection, a combination of steam and convection heat, and retherm. Oven is to be constructed of 18 gauge stainless steel interior cavity. Oven includes an attached retractable hand shower spray hose with safety shutoff interlock system and a backflow preventer. PROtouch™ control features includes a cool-down function, automatic cleaning function, recipe programming, two power levels, 0-100% humidity levels, auto-reversing fan with five (5) fan speeds, multi-shelf timers, and sleep mode. Oven includes USB port, HACCP data access, and four (4) adjustable stainless steel legs. Each oven is to accommodate up to ten (10) full-size sheet pans or twenty (20) full-size hotel pans (GN 1/1), include standard right-hand door hinging, ten (10) non-tilt support rails, and six (6) stainless steel shelves. Oven to be provided with Cool Touch 3 Triple pane window door with hinged inner glass to prevent additional heat loss and increase safety and cooking efficiency.

Stand: 5016084 Combi Therm Combi oven stand, stationary with pan slides and shelf.

Interior Dimensions: (HxWxD) 31-1/2" x 24-1/4" x 32-3/4" (800mm x 616mm x 832mm);

Exterior Dimensions: (HxWxD) 45-11/16" x 43-3/4" x 46-3/16" (1160mm x 1111mm x 1173mm)

Water Requirements: ONE (1) TREATED WATER INLET: 3/4" NPT* ONE (1) UNTREATED WATER INLET: 3/4" NPT* LINE PRESSURE: 30 to 90 psi 2.1 to 6.3 bar

Water Drain: 1-1/2" (40mm) CONNECTION WITH A 2" (51mm) MINIMUM AIR GAP INSTALLED AS CLOSE TO THE OVEN AS POSSIBLE. MATERIALS MUST WITHSTAND TEMPERATURES UP TO 200°F (93°C). Can Manifold off of one ¾" line.

Filter: Complete with Optipure QTI-1 Filtration System 2 each.

Electrical Requirements: (NO CORD, NO PLUG, DEDICATED CIRCUIT REQUIRED) DO NOT CONNECT TO A G.F.I. OUTLET: 480V/3-ph, 68.8-79.4 amps, 24.8-33kw, 2-1AWG

Warranty: Two year manufacturer's warranty, all parts and labor must be included in the unit price. Installation: Unit price must include inside delivery, uncrating, set in place, remove cartons and tape, installation of shelves and accessories, level, factory start up, disposal of packaging materials and training. Service manuals, parts lists and wiring diagrams must accompany each delivered unit. Final electrical, plumbing and gas connections will be done by SBBC Personnel.

Approved Brand: Alto-Sham Model CTP10-20E only.

Brand Offered: _____

Model Offered: _____

Warranty Period: _____

Delivery (days ARO): _____

SECTION 6 - BID SPECIFICATIONS – (CONTINUED)

In order to be considered for award, Bidders must fill these Bid Specifications Forms and the Electronic Bid Summary Sheet and submit them with their bid, in time for bid opening.

ITEM 47 – TO BE AWARDED AS A GROUP

Item #

47A SAP Number: SAP #6006255

Item Name: SLIDING TOP MILK CASE DISPENSER – 10 CASE MIN. CAPACITY

Description: Minimum 10 case capacity. Dimensions not to exceed 57" x 35-3/8"x 36" H. Body to be seamless molded fiberglass with smooth exterior surfaces and rounded corners. To be constructed of four layers of continuous strand fiberglass mat with a 24 oz. layer of woven roving on the bottom for added strength. Fiber-glass to be flame retardant per ASTM E-162. Body interior to be reinforced at each end with 4" wide, 12 gauge galvanized channels welded to form integral "U" frame for maximum stress relief. Refrigerated interior to be a welded steel cabinet with a water tight liner, fully insulated and with a 1" brass drain extended below body to a shut off valve. Top to be 14 gauge stainless steel w/square turndown on all sides and corners fully welded, ground, and polished. To have #4 satin finish. Interior top to turn down into opening with integral ledges to support sliding lids. Lids shall be 18 gauge stainless steel double pan construction with s/s handles. Cabinet and lids are fully insulated with urethane insulation. Each milk crate to be held at proper height by two stainless steel self-leveling mechanisms, field adjustable w/out tools. Refrigeration shall maintain at 38° by a cold wall evaporator system, with an accessible expansion valve. Casters to be 4" diameter, ball bearing, swivel type with brakes on all wheels. Casters mounted thru 12 gauge channels for extra rigidity.

Warranty: Two year manufacturer's warranty, all parts and labor must be included in the unit price.

Installation: Unit price must include inside delivery, uncrating, set in place, remove cartons and tape, installation of shelves and accessories, level, factory start up, disposal of packaging materials and training. Service manuals, parts lists and wiring diagrams must accompany each delivered unit. Final electrical, plumbing and gas connections will be done by SBBC Personnel.

Approved Brand: Low Temp Colorpoint Model CPM-1310 or other brands meeting bid specifications.

Brand Offered: _____

Model Offered: _____

Warranty Period: _____

Delivery (days ARO): _____

SECTION 6 - BID SPECIFICATIONS – (CONTINUED)

In order to be considered for award, Bidders must fill these Bid Specifications Forms and the Electronic Bid Summary Sheet and submit them with their bid, in time for bid opening.

ITEM 47 – TO BE AWARDED AS A GROUP - CONTINUED

Item #

47B SAP Number: SAP # 6006256

Item Name: SLIDING TOP MILK CASE DISPENSER-6 CASE MIN. CAPACITY

Description: Minimum 6 case capacity. Dimensions not to exceed 40" x 35-3/8"x 36"H. Body to be seamless molded fiberglass with smooth exterior surfaces and rounded corners. To be constructed of four layers of continuous strand fiberglass mat with a 24 oz. layer of woven roving on the bottom for added strength. Fiber-glass to be flame retardant per ASTM E-162. Body interior to be reinforced at each end with 4" wide, 12 gauge galvanized channels welded to form integral "U" frame for maximum stress relief. Refrigerated interior to be a welded steel cabinet with a water tight liner, fully insulated and with a 1" brass drain extended below body to a shut off valve. Top to be 14 gauge stainless steel w/square turndown on all sides and corners fully welded, ground, and polished. To have #4 satin finish. Interior top to turn down into opening with integral ledges to support sliding lids. Lids shall be 18 gauge stainless steel double pan construction with s/s handles. Cabinet and lids are fully insulated with urethane insulation. Each milk crate to be held at proper height by two stainless steel self-leveling mechanism, field adjustable w/out tools. Refrigeration shall maintain at 38° by a cold wall evaporator system, with an accessible expansion valve. Casters to be 4" diameter, ball bearing, swivel type with brakes on all wheels. Casters mounted thru 12 gauge channels for extra rigidity.

Warranty: Two year manufacturer's warranty, all parts and labor must be included in the unit price.

Installation: Unit price must include inside delivery, uncrating, set in place, remove cartons and tape, installation of shelves and accessories, level, factory start up, disposal of packaging materials and training. Service manuals, parts lists and wiring diagrams must accompany each delivered unit. Final electrical, plumbing and gas connections will be done by SBBC Personnel.

Approved Brand: Low Temp Colorpoint Model CPM-1306 or other brands meeting bid specifications.

Brand Offered: _____

Model Offered: _____

Warranty Period: _____

Delivery (days ARO): _____

SECTION 6.1 - ILLUSTRATIONS

BID ITEM 6A/6B

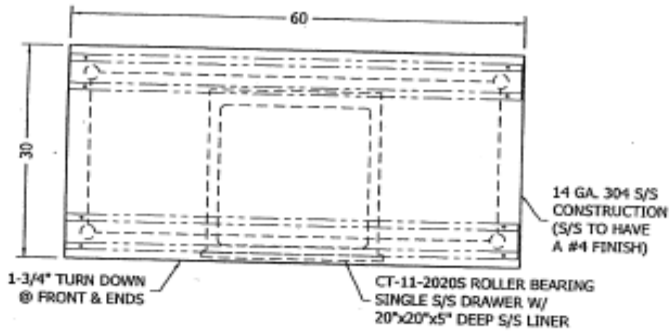

- NOTE:
1. ALL VISIBLE WELDS TO BE GROUND SMOOTH & POLISHED TO A MATCHING FINISH.
 2. ALL NON-VISIBLE WELDS TO BE GROUND SMOOTH & PAINTED
 3. ALL EDGES TO BE SMOOTH & FREE FROM BURRS

Item A

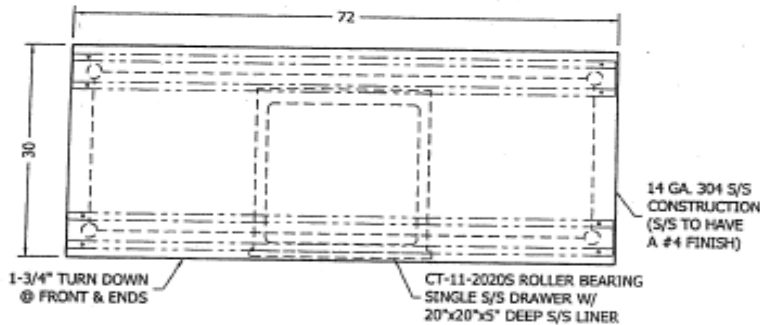
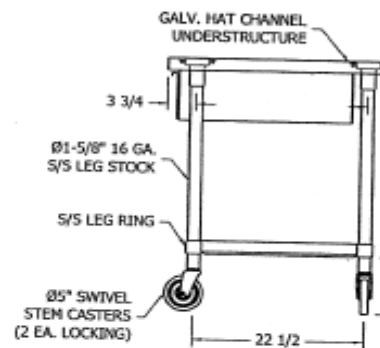
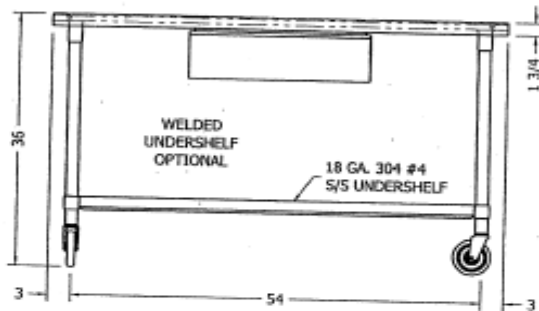

- NOTE:
1. ALL VISIBLE WELDS TO BE GROUND SMOOTH & POLISHED TO A MATCHING FINISH.
 2. ALL NON-VISIBLE WELDS TO BE GROUND SMOOTH & PAINTED
 3. ALL EDGES TO BE SMOOTH & FREE FROM BURRS

Item B

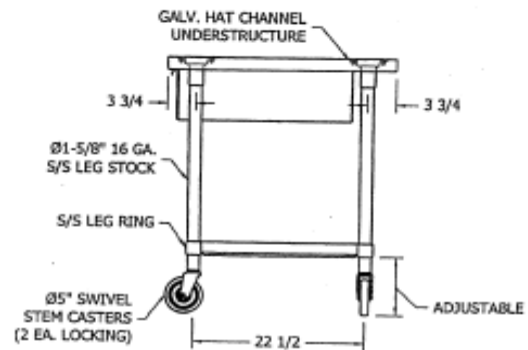
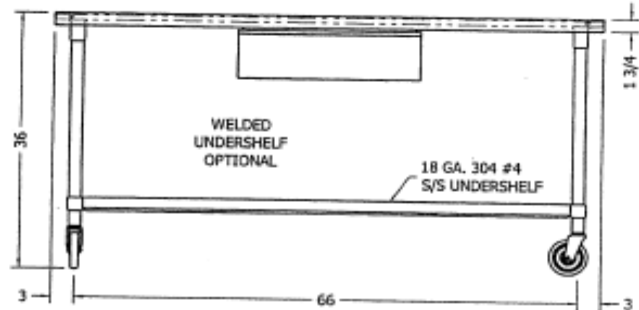

SECTION 6.1 – ILLUSTRATIONS (CONTINUED)

BID ITEM 7A

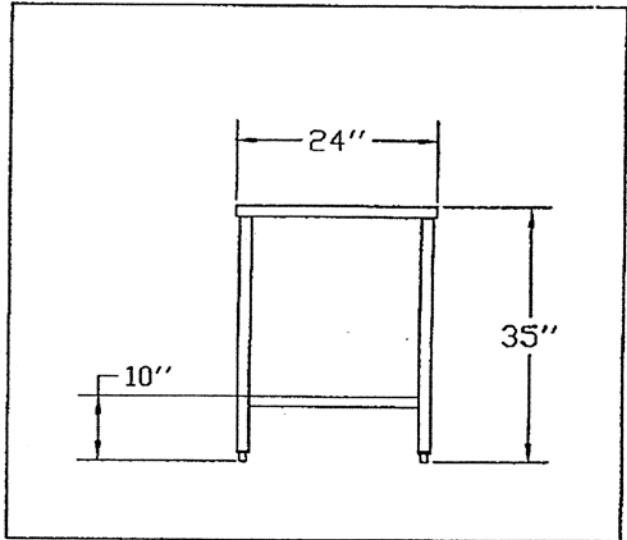
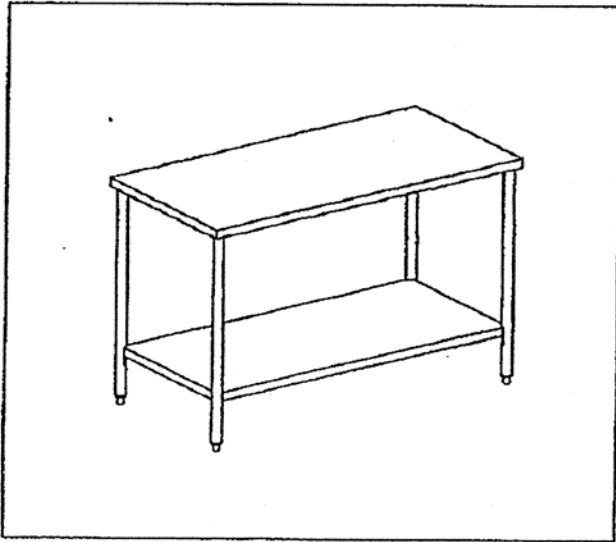

*All stainless steel construction 304 Top 14 ga undershelf 18 ga
no casters no Drawers.*

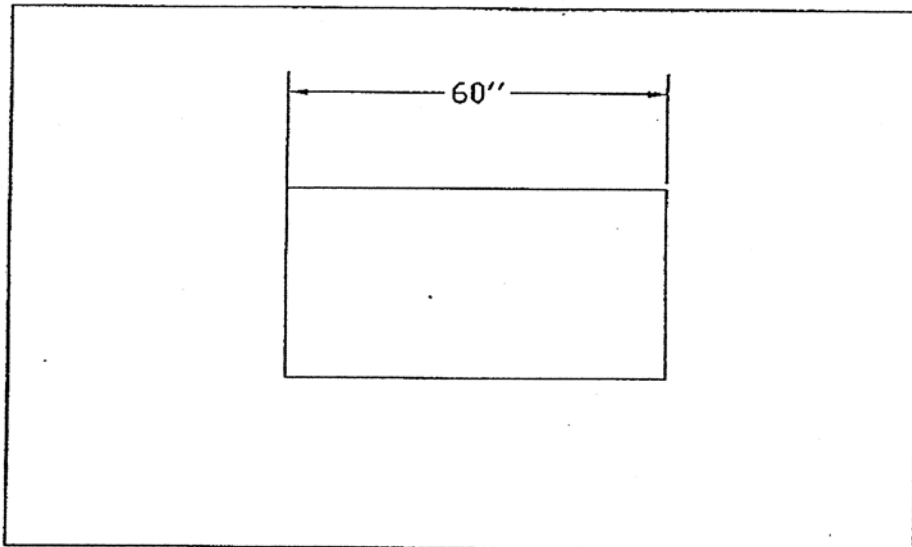

SECTION 6.1 – ILLUSTRATIONS (CONTINUED)

BID ITEM 7B

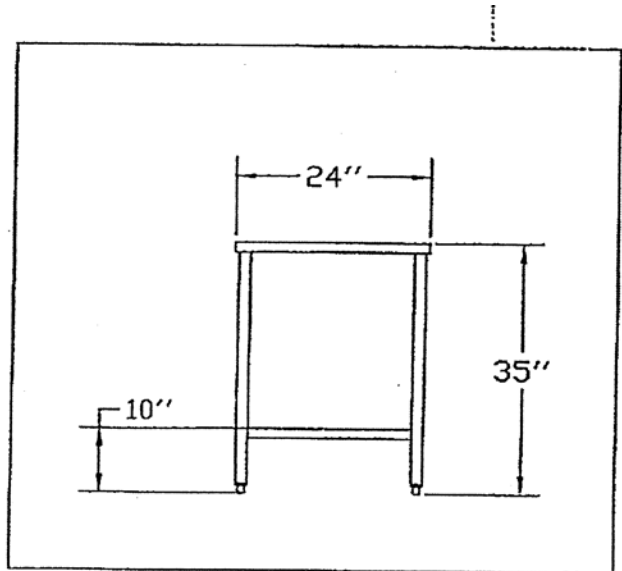
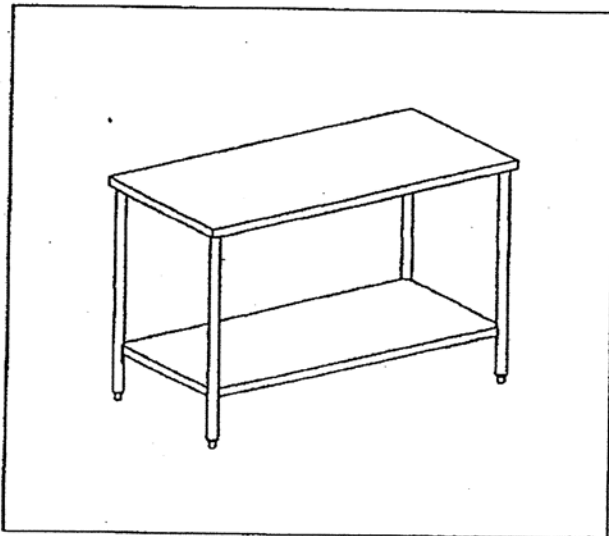

*All stainless steel construction 304 Top 14 ga undershelf 18 ga
no casters no Drawers.*

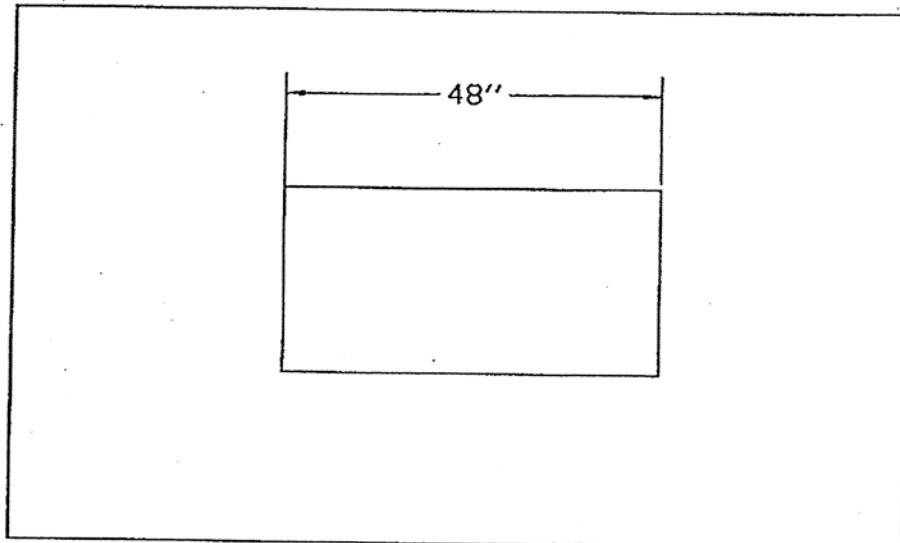

SECTION 6.1 – ILLUSTRATIONS (CONTINUED)

BID ITEM 7C

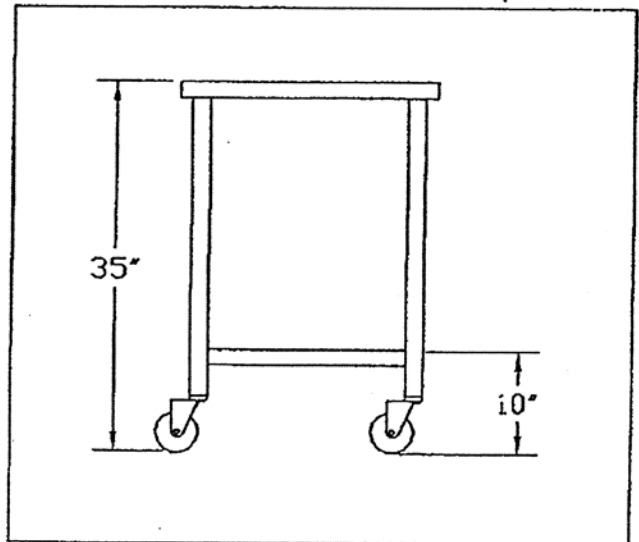
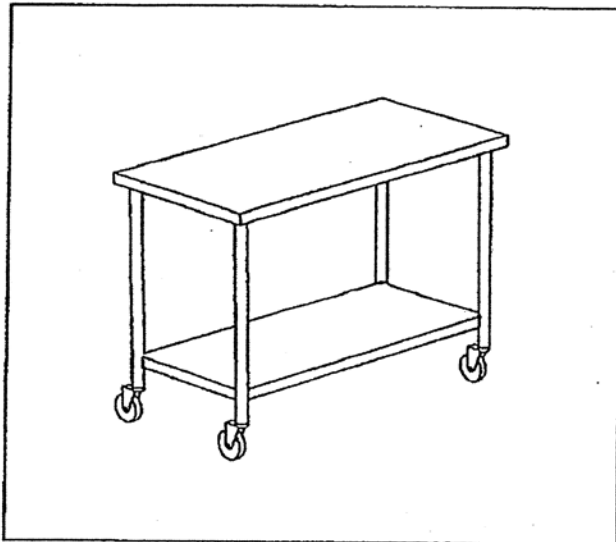

*All stainless steel construction 304 14 Ga top 18 Ga shelf
With casters*

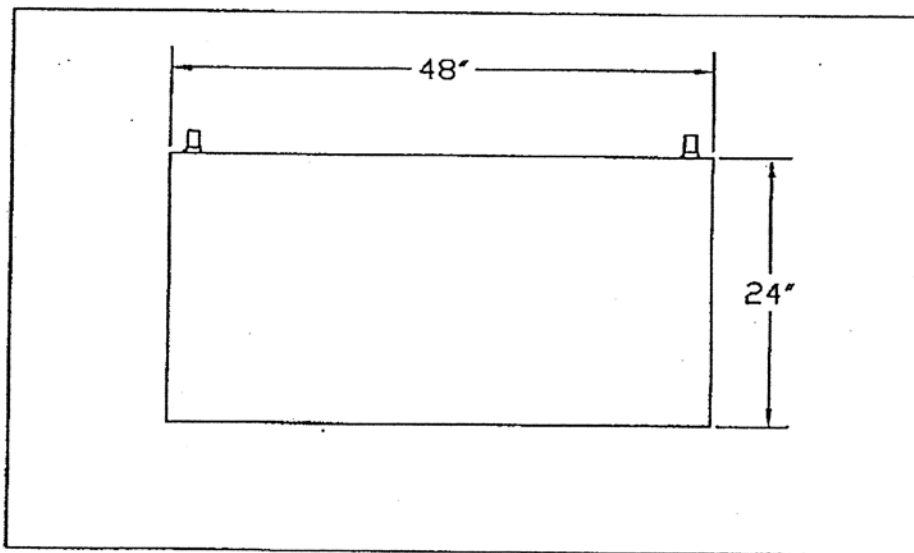

SECTION 6.1 – ILLUSTRATIONS (CONTINUED)

BID ITEM 7D

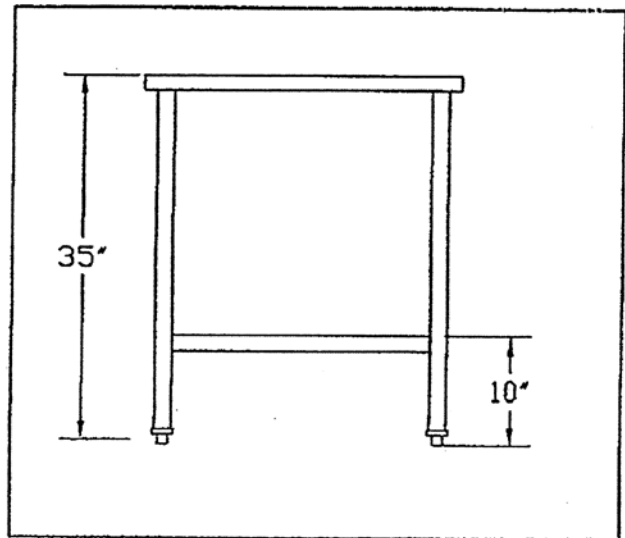
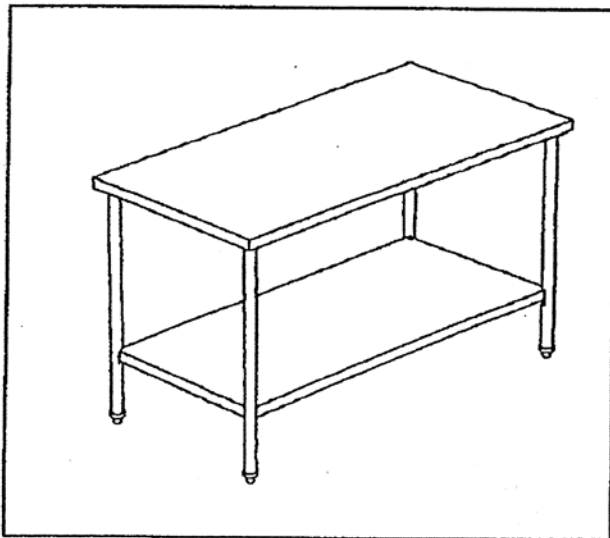

*All stainless steel construction 304 14 Ga top 18 Ga shelf
With casters*

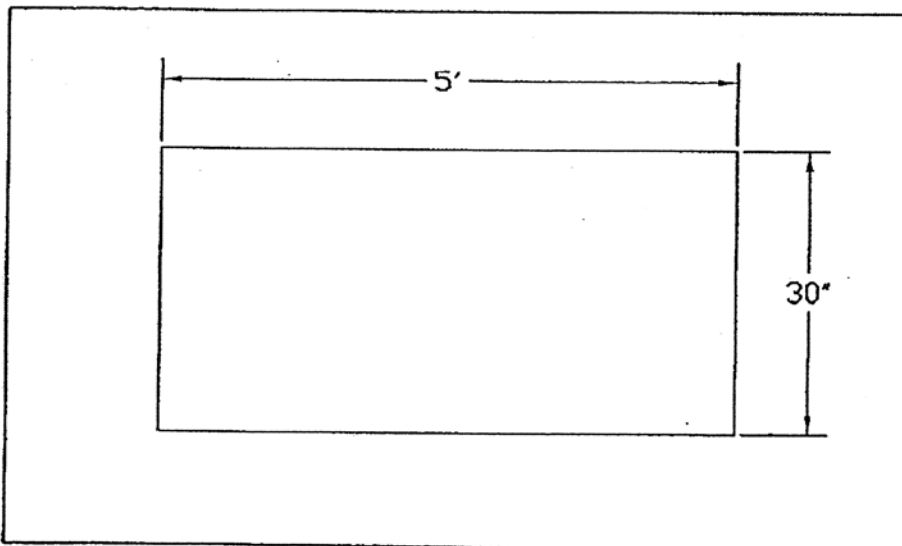

SECTION 6.1 – ILLUSTRATIONS (CONTINUED)

BID ITEM 7E

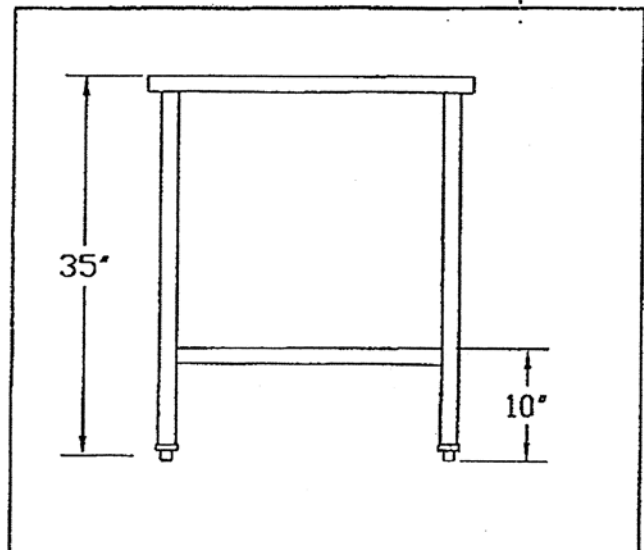
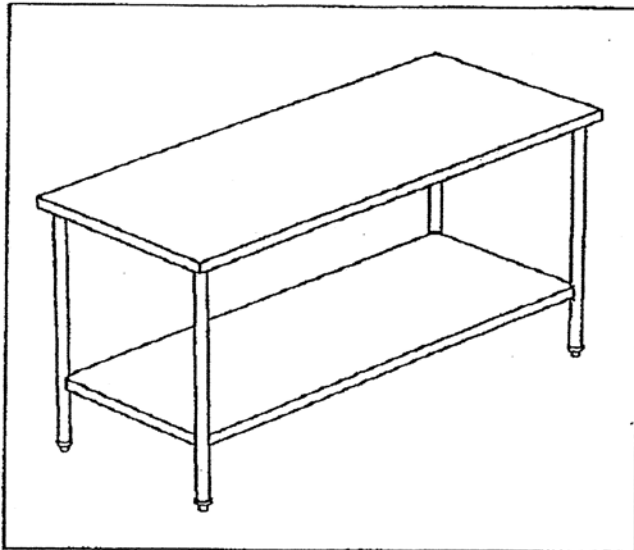

*All stainless steel construction 304 14 Ga top 18 Ga shelf
With casters*

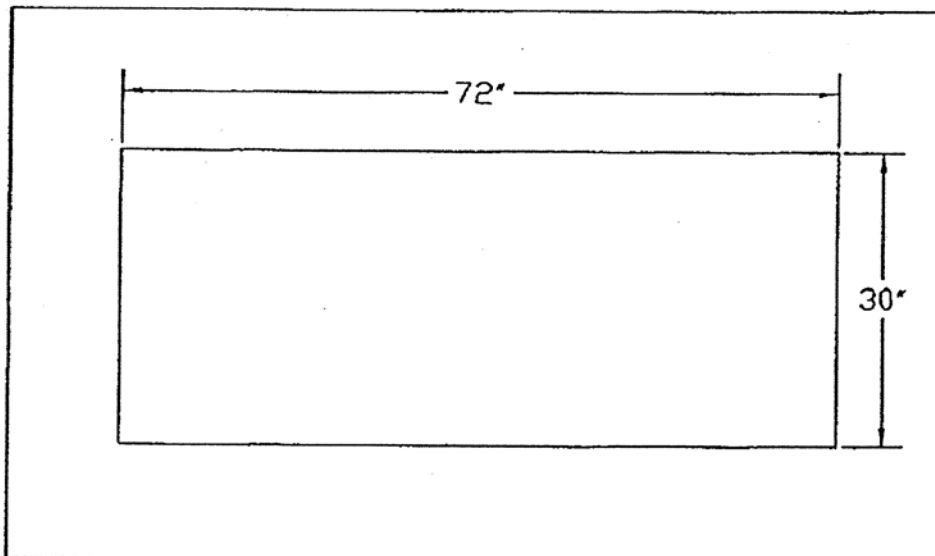

SECTION 6.1 – ILLUSTRATIONS (CONTINUED)

BID ITEM 7F

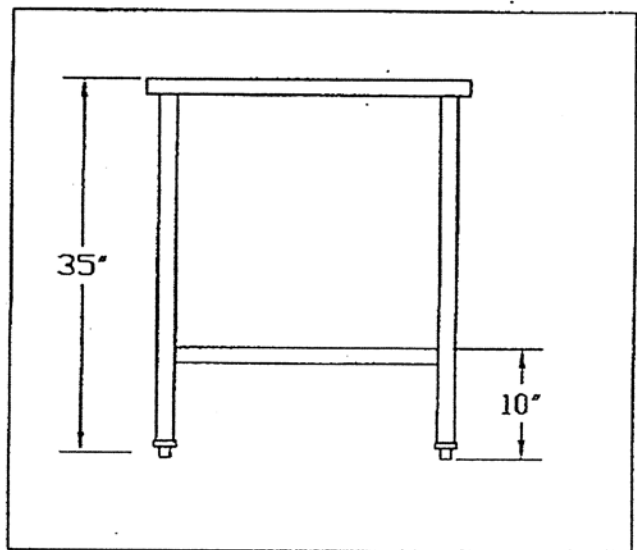
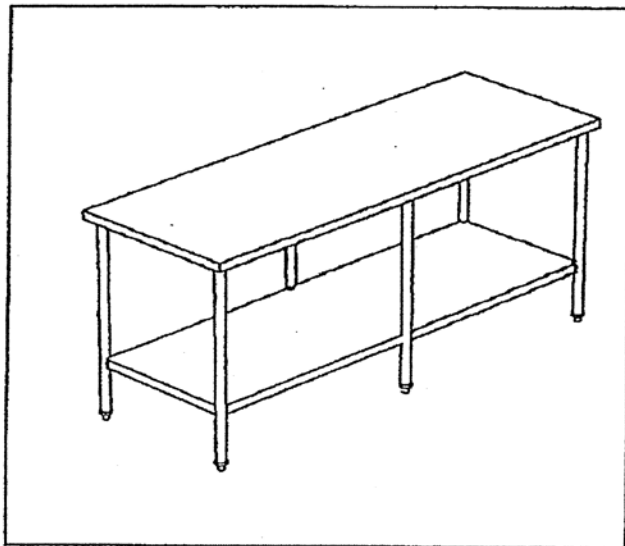

*All stainless steel construction 304 14 Ga top 18 Ga shelf
With casters*

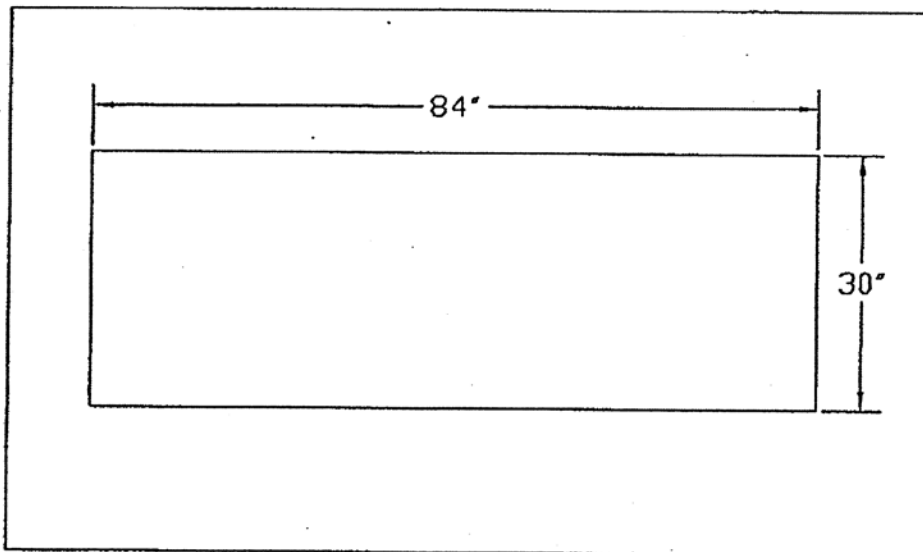

SECTION 6.1 – ILLUSTRATIONS (CONTINUED)

BID ITEM 8

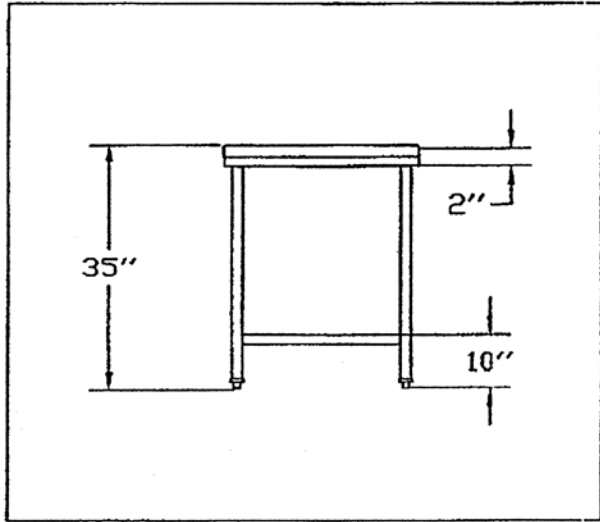
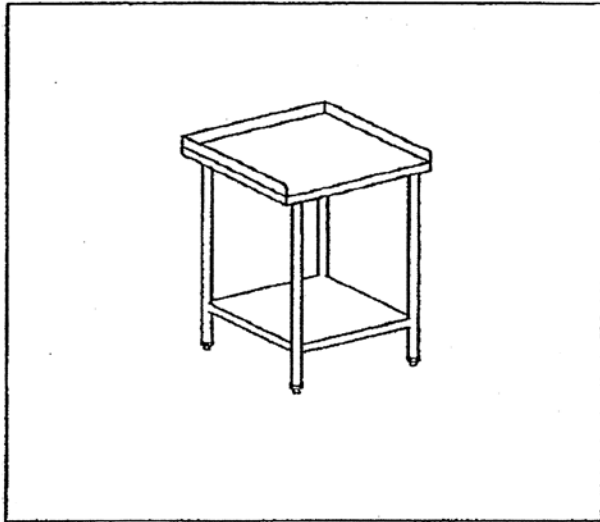

*All stainless steel construction 304 Top 14 ga undershelf 18 ga
no casters no Drawers.*

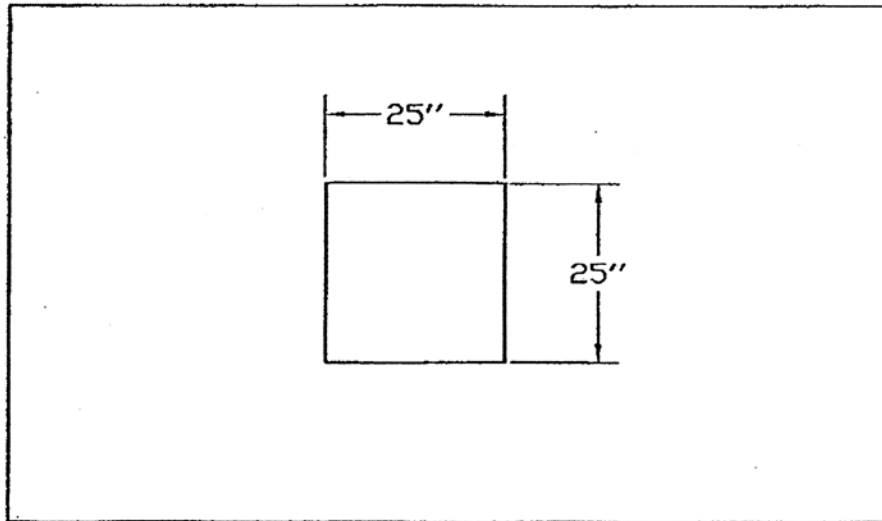

SECTION 6.1 – ILLUSTRATIONS (CONTINUED)

BID ITEM 30

ATTACHMENT "A"

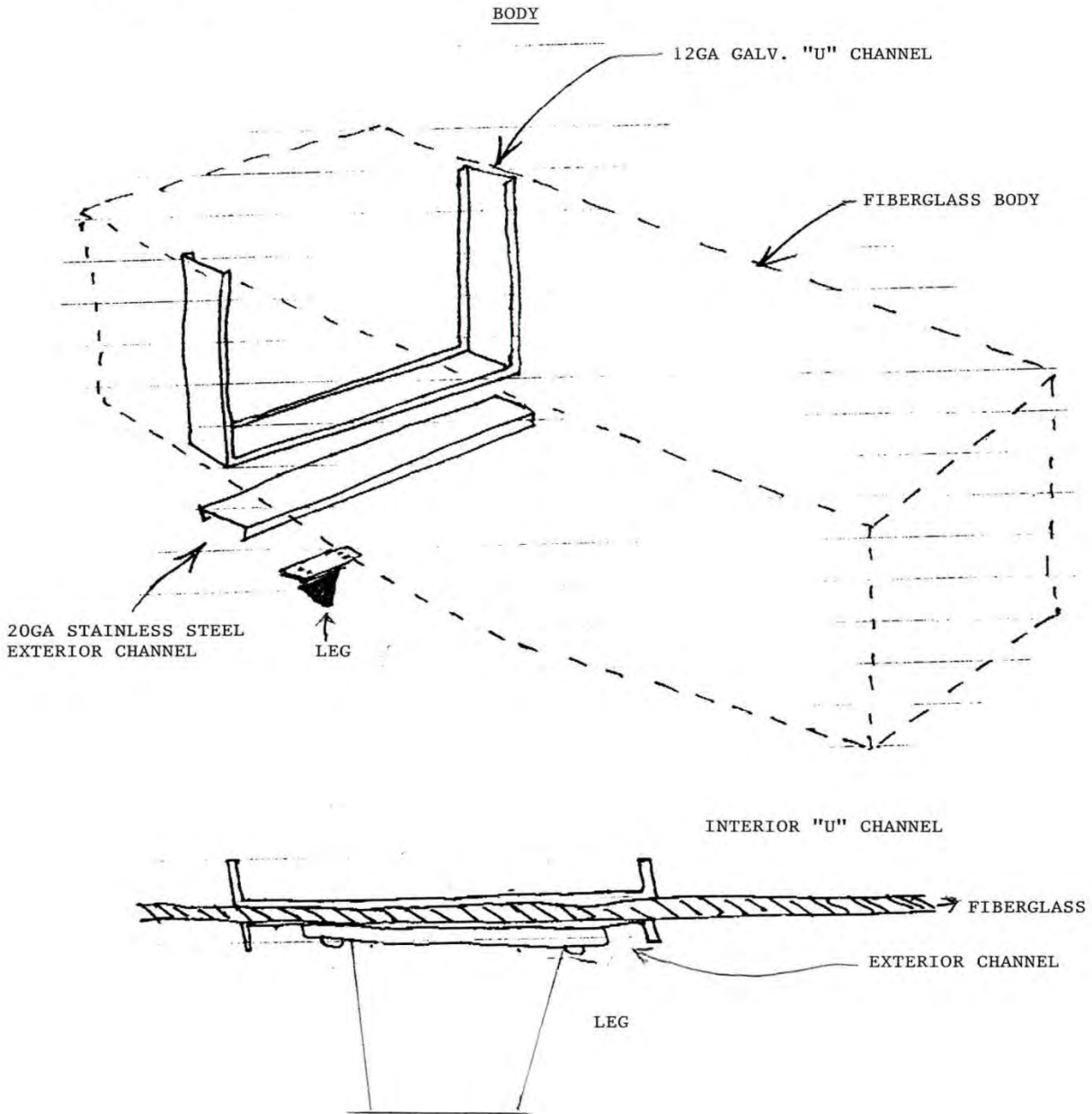

SECTION 6.1 – ILLUSTRATIONS (CONTINUED)

BID ITEM 30

ATTACHMENT "B"

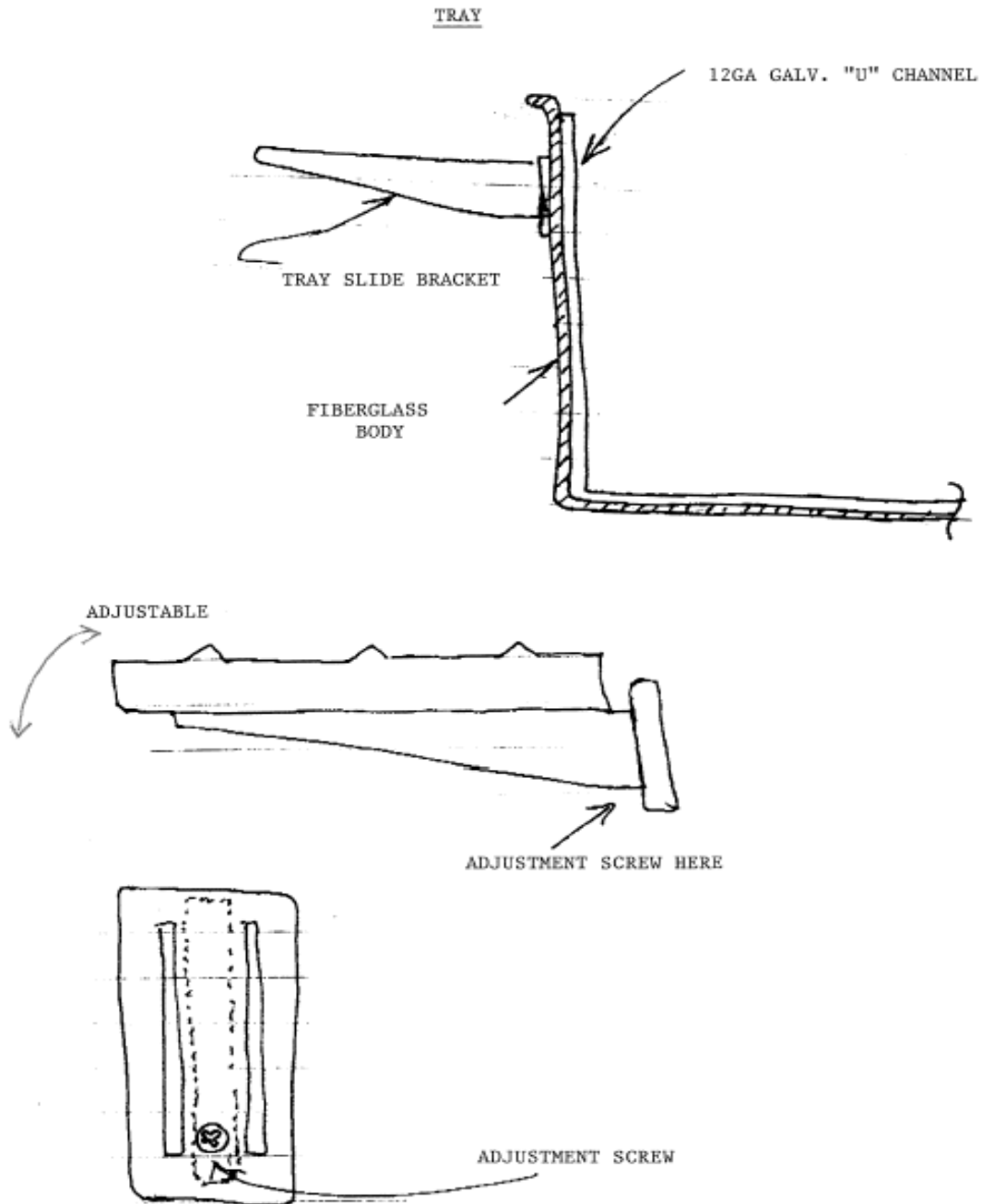

SECTION 6.1 – ILLUSTRATIONS (CONTINUED)

BID ITEM 44A / 44B

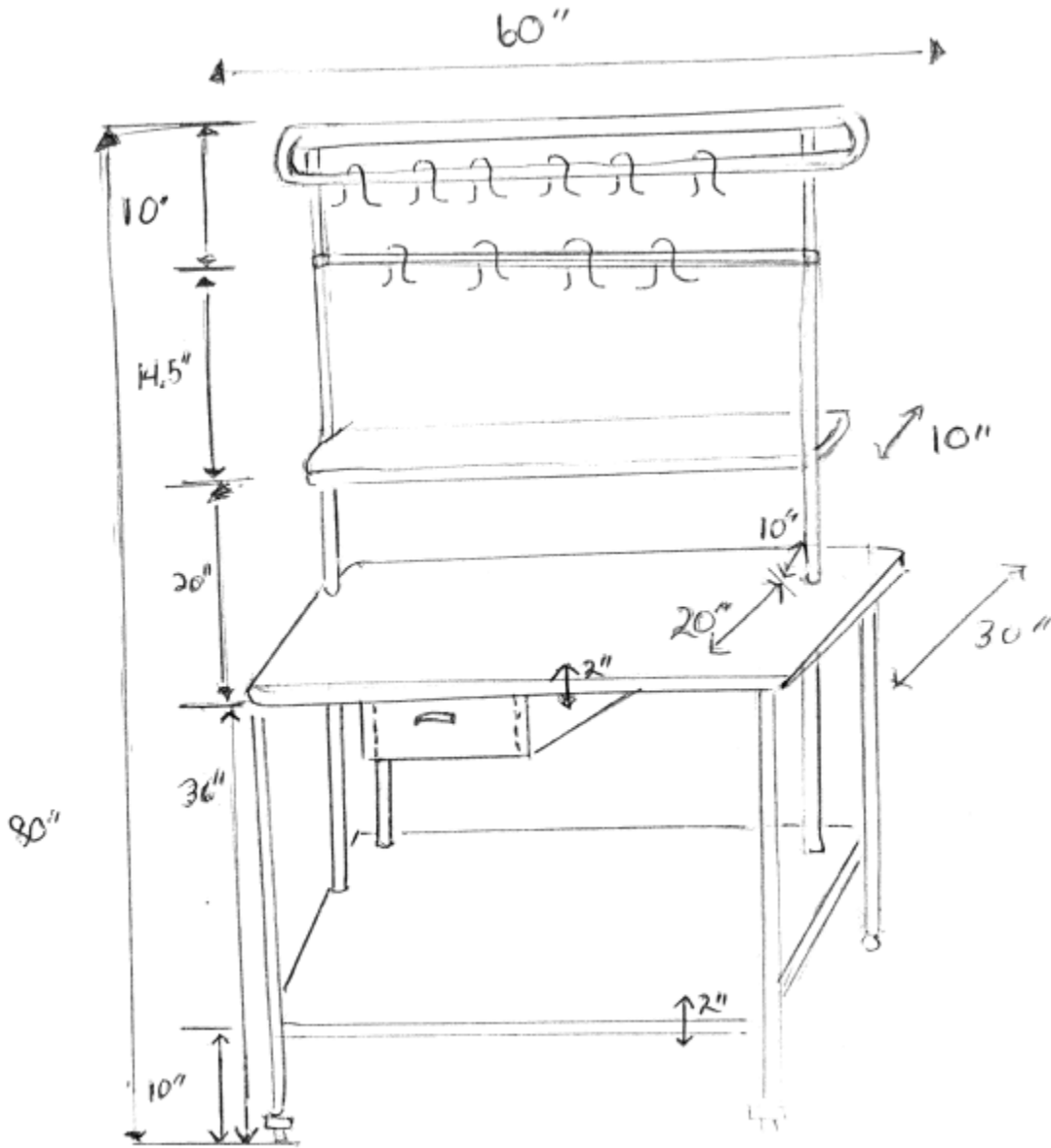

SECTION 7, FORMS AND ATTACHMENTS

Please fill out all attachments below. Some attachments must be notarized.

ATTACHMENT 1

DISCLOSURE OF POTENTIAL CONFLICT OF INTEREST AND CONFLICTING EMPLOYMENT OR CONTRACTUAL RELATIONSHIP

In accordance with General Condition 11, each Bidder must disclose in its Bid, the names of any employees who are employed by Bidder who are also an employee of SBBC. Persons identified below may have obligations and restrictions applicable to them under Chapter 112, Florida Statutes.

Name of Bidder's Employee	SBBC Title or Position of Bidder's Employee	SBBC Department/ School of Bidder's Employee
_____	_____	_____
_____	_____	_____
_____	_____	_____
_____	_____	_____
_____	_____	_____

Check one of the following and sign:

I hereby affirm that there are no known persons employed by Bidder who are also an employee of SBBC.

I hereby affirm that all known persons who are employed by Bidder who are also an employee of SBBC have been identified above.

Signature

Company Name

03/28/13

**ATTACHMENT 2
DRUG FREE WORKPLACE**

THE SCHOOL BOARD OF BROWARD COUNTY, FLORIDA

SWORN STATEMENT PURSUANT TO SECTION 287.087, FLORIDA STATUTES, AS CURRENTLY ENACTED OR AS AMENDED FROM TIME TO TIME, ON PREFERENCE TO BUSINESSES WITH DRUG-FREE WORKPLACE PROGRAMS.

THIS FORM MUST BE SIGNED AND SWORN TO IN THE PRESENCE OF A NOTARY PUBLIC OR OTHER OFFICIAL AUTHORIZED TO ADMINISTER OATHS.

This sworn statement is submitted to The School Board of Broward County, Florida,

by _____
(Print individual's name and title)

for _____
(Print name of entity submitting sworn statement)

whose business address is _____

and (if applicable) its Federal Employer Identification Number (FEIN) is _____
(If the entity has no FEIN, include the Social Security Number of the individual signing this sworn statement: _____.)

I certify that I have established a drug-free workplace program and have complied with the following:

1. Published a statement notifying employees that the unlawful manufacture, distribution, dispensing, possession, or use of a controlled substance is prohibited in the workplace and specifying the actions that shall be taken against employees for violations of such prohibition.
2. Informed employees about the dangers of drug abuse in the workplace, the business' policy of maintaining a drug-free workplace, any available drug counseling, rehabilitation and employee assistance programs, and the penalties that may be imposed upon employees for drug abuse violations.
3. Given each employee engaged in providing the commodities or contractual services that are under bid a copy of the statement specified in subsection (1).
4. In the statement specified in subsection (1), notified the employees that, as a condition of working on the commodities or contractual services that are under bid, the employee shall abide by the terms of the statement and shall notify the employer of any conviction of, or plea of guilty or nolo contendere to, any violation of chapter 893 or of any controlled substance law of the United States or any state, for a violation occurring in the workplace no later than five days after such conviction.
5. Shall impose a sanction on, or require the satisfactory participation in a drug abuse assistance or rehabilitation program if such is available in the employee's community by, any employee who is so convicted.
6. Am making a good faith effort to continue to maintain a drug free workplace through implementation of this section.

Sworn to and subscribed before me this _____ day of _____, 20____.

Personally known _____ or _____
Produced Identification _____

(Type of Identification)

(Signature)
Notary Public – State of _____
My commission expires: _____

Form #4530
3/93

(Printed, typed, or stamped commissioned name of notary public)

ATTACHMENT 3

MINIMUM LIMITS OF INSURANCE REQUIREMENTS

GENERAL LIABILITY: Limits not less than \$1,000,000 per occurrence for Bodily Injury/ Property Damage; \$1,000,000 General Aggregate.

Limits not less than \$1,000,000 for Products/Completed Operations Aggregate.

WORKER'S COMPENSATION: Florida Statutory limits in accordance with Chapter 440; Employer's Liability limits not less than \$100,000/\$100,000/\$500,000 (each accident/disease-each employee/disease-policy limit).

AUTO LIABILITY: Owned, Non-Owned and Hired Auto Liability with Bodily Injury and Property Damage limits of not less than \$1,000,000 Combined Single Limit.

If Awardee does not own any vehicles, hired and non-owned automobile liability coverage in the amount of \$1,000,000 shall be accepted. In addition, an affidavit signed by the Awardee must be furnished to SBBC indicating the following:

_____ (Awardee Name) does not own any vehicles. In the event insured acquires any vehicles throughout the term of this agreement, insured agrees to provide proof of "Any Auto" coverage effective the date of acquisition. (Fax affidavit with Certificate of Insurance to SBBC Risk Management at 866-897-0424.)

ACCEPTABILITY OF INSURANCE CARRIERS: The insurance policies shall be issued by companies qualified to do business in the State of Florida. The insurance companies must be rated at least A- VI by AM Best or Aa3 by Moody's Investor Service.

VERIFICATION OF COVERAGE: Proof of the required insurance must be furnished by an Awardee to SBBC Risk Management Department by Certificate of Insurance within 15 days of notification of award. All certificates (and any required documents) must be received and approved by SBBC before any work commences to permit Awardee time to remedy any deficiencies.

FAX CERTIFICATES OF INSURANCE TO SBBC RISK MANAGEMENT AT 866-897-0424.

REQUIRED CONDITIONS: Liability policies must contain the following provisions. In addition, the following wording must be included on the Certificate of Insurance:

The School Board of Broward County, FL, its members, officers, employees and agents are added as additional insured. The endorsement # is: _____.

All liability policies are primary of all other valid and collectable coverage maintained by the School Board of Broward County, Florida.

(**Please include the Contract # and Title on the Certificate of Insurance.)

(Certificate Holder: School Board of Broward County, 600 Southeast Third Avenue, Fort Lauderdale, Florida 33301.)

CANCELLATION OF INSURANCE: Vendors are prohibited from providing services under this contract with SBBC without the minimum required insurance coverage and must notify SBBC within two business days if required insurance is cancelled.

Any questions as to the intent or meaning of any part of the above required coverage should be submitted in writing and in accordance with General Condition 5. See also General Conditions 12 and 20.

The School Board of Broward County, Florida reserves the right to review, reject or accept any required policies of insurance, including limits, coverage's or endorsements, herein throughout the term of this contract.

ATTACHMENT 4
See Special Condition 5

LEGAL OPINION OF BIDDER'S PREFERENCE
MUST BE COMPLETED BY ALL BIDDERS.

(Must Select One)

This form should be accompanied by a printout of the bidder's corporation record as registered with the Division of Corporations, Florida Department of State which can be accessed at www.sunbiz.org

Section 1 must be completed by the Attorney for an Out-of-State Bidder
Section 2 must be completed and signed by Florida Bidder

NOTICE: The State of Florida provides a Bidder's preference for Bidders whose principal place of business is within the State of Florida for the purchase of personal property. The local preference is five (5) percent. Bidders whose principal place of business is outside the State of Florida must have an Attorney, licensed to practice law in the out-of-state jurisdiction, as required by Florida Statute 287.084(2), execute the "Opinion of Out-of-State Bidder's Attorney on Bidding Preferences" form, Section 7, Attachment 4, and must submit this form with submitted bid. Such opinion should permit SBBC's reliance on such attorney's opinion for purposes of complying with Florida Statute 287.084. Florida Bidders are not required to have an Attorney render an opinion but the Florida Bidder must complete its portion of this form. **Failure to submit and execute this form, with bid, shall result in bid being considered "non-responsive" and bid rejected.**

SECTION 1
LEGAL OPINION ABOUT OUT-OF-STATE BIDDING PREFERENCES
Must be completed by an Attorney for an OUT-OF-STATE Bidder

_____ The Bidder's principal place of business is in the State of _____ and it is my legal opinion that the laws of that state **do not grant a preference** in the letting of any or all public contracts to business entities whose principal places of business are in that state.

_____ The Bidder's principal place of business is in the State of _____ and it is my legal opinion that the laws of that state **grant the following preference(s)** in the letting of any or all public contracts to business entities whose principal places of business are in that state: [Please describe applicable preference(s) and identify applicable state law(s)]:

The undersigned attorney submits the foregoing opinions with the intention that they be relied upon by The School Board of Broward County, Florida in the letting of public contracts

Signature of out-of-state Bidder's attorney: _____

Printed name of out-of-state Bidder's attorney: _____

Address out-of-state Bidder's attorney: _____

Telephone number out-of-state Bidder's attorney: _____

E-Mail address out-of-state Bidder's attorney: _____

Attorney's state(s) of bar admission: _____

SECTION 2
LEGAL OPINION ABOUT POLITICAL SUBDIVISION BIDDING PREFERENCES FOR A FLORIDA BIDDER ONLY
ATTORNEY'S OPINION AND SIGNATURE NOT REQUIRED FOR FLORIDA BIDDERS
(Must Select One)

_____ The Bidder's principal place of business is in the political subdivision of Broward County, Florida.

_____ The Bidder's principal place of business is in the political subdivision of _____ and it is my legal opinion that the laws of that political subdivision **do not grant a preference** in the letting of any or all public contracts to business entities whose principal places of business are in that political division.

_____ The Bidder's principal place of business is in the political subdivision of _____ and it is my legal opinion that the laws of that political subdivision **grant the following preference(s)** in the letting of any or all public contracts to business entities whose principal places of business are in that political subdivision: [Please describe applicable preference(s) and identify applicable authority granting the preference(s)]: _____

ATTACHMENT 5

W-9 Form

Please retrieve the latest version of the W-9 form from the IRS website listed below:

<https://www.irs.gov/pub/irs-pdf/fw9.pdf>

- This form can be filled out online and printed for signature. Only page one (1) needs to be returned



ATTACHMENT 6

ACH Payment Agreement Form (ACH CREDITS)
The School Board of Broward County, Florida
(See General Condition 10)

VENDOR NAME:

Authorization Agreement

I (we) hereby authorize **The School Board of Broward County** to initiate automatic deposits (credits) to my account at the financial institution named below. Additionally, I authorize **The School Board of Broward County** to make the necessary debit entries/adjustments in the event that a credit entry is made in error.

Further, I agree not to hold **The School Board of Broward County** responsible for any delay or loss of funds due to incorrect or incomplete information supplied by me or by my financial institution or due to an error on the part of my financial institution in depositing funds to my account.

This agreement shall remain in effect until **The School Board of Broward County** receives written notification of cancellation from me or my financial institution and that the origination of ACH transactions to my (our) account must comply with the provisions of U.S. law.

Account Information

Name of Bank or Financial Institute: _____

Branch/ State _____

Routing No: _____

Account No: _____
VENDOR AREA: _____
Remittance Confirmation: (please select one) _____

Checking Savings

Fax Email

Federal Identification No. Vendor _____
TAX ID# SS#

Update Purchase Order Fax & Email Address

Centralized Fax Number _____ Dept. _____

Centralized Email _____ Dept. _____

Centralized Phone No. _____ Dept. _____

Signature

Authorized Signature (Primary) and Business title: _____ Date: _____

Authorized Signature (Joint) and Business title: _____ Date: _____

Please attach a VOIDED check to verify bank details and routing number.

This form must be returned to: SBBC – Purchasing – Data Strategy Group
7720 W. Oakland Park Blvd, Sunrise FL 33351 call: 754-321-0516 or fax # 754-321-0533

For Use by DATA STRATEGY GROUP

Vendor Account# _____ Date Entered _____ Initials: _____

SECTION 8, STATEMENT OF "NO BID"

If your company shall not be submitting a bid in response to this Invitation to Bid, please complete this Statement of "No Bid" Sheet and return, prior to the Bid Due Date established within, to:

The School Board of Broward County, Florida
 Procurement and Warehousing Services
 7720 West Oakland Park Boulevard, Suite 323
 Sunrise, Florida 33351

This information shall help SBBC in the preparation of future Bids.

Bid Number: _____ Title: _____

Company Name: _____

Contact: _____

Address: _____

Telephone: _____ Facsimile: _____

√	Reasons for "NO Bid":
	Unable to comply with product or service specifications.
	Unable to comply with scope of work.
	Unable to quote on all items in the group.
	Insufficient time to respond to the Invitation to Bid.
	Unable to hold prices firm through the term of the contract period.
	Our schedule would not permit us to perform.
	Unable to meet delivery requirements.
	Unable to meet bond requirements.
	Unable to meet insurance requirements.
	Other (Specify below)

Comments:

Signature: _____ Date: _____



EXHIBIT A1

**MINORITY/WOMEN BUSINESS ENTERPRISE (M/WBE)
 PARTICIPATION FORM**

Bidder's (Company) Name: _____

Complete the following information on the proposed M/WBE participation on this contract. Total percentage should not exceed 100%. If proposer is an M/WBE, proposer should be listed below. If proposer is not an M/WBE, percentage should not equal 100% unless the total work (100%) to be performed under this contract will be subcontracted to M/WBEs.

M/WBE Firm Information	Scope and/or Nature of Work to be Performed by the M/WBE	% of M/WBE Participation for this contract
Firm Name: _____ Contact Person: _____ Address: _____ _____ Telephone No.: _____ Facsimile No.: _____ SBBC M/WBE Certification No.: _____		
Firm Name: _____ Contact Person: _____ Address: _____ _____ Telephone No.: _____ Facsimile No.: _____ SBBC M/WBE Certification No.: _____		
Firm Name: _____ Contact Person: _____ Address: _____ _____ Telephone No.: _____ Facsimile No.: _____ SBBC M/WBE Certification No.: _____		

FOR INFORMATION ON M/WBE CERTIFIED VENDORS, PLEASE CONTACT THE SUPPLIER DIVERSITY & OUTREACH PROGRAM OFFICE (754) 321-0550, OR ONLINE AT <http://www.broward.k12.fl.us/supply/sdop/vendorlist.html>

Exhibit A2

 <p>BROWARD County Public Schools</p>	<p>The School Board of Broward County, Florida Supplier Diversity & Outreach Program 7720 W. Oakland Park Blvd., Suite 323 Sunrise, FL 33351 (754) 321-0505 ~ Fax (754) 321-0534</p>
----------------------------------------------------------------------------------------------------------------------------------	------------------------------------------------------------------------------------------------------------------------------------------------------------------------------------------------------------------------------------------------------------------------------

Monthly M/WBE Subcontractor Utilization Report

The timing of the reports must coincide with invoice submission, whether the M/WBE(s) received payment or not, until all committed remuneration has been received by the M/WBE vendor.

Reporting Period From: _____ Reporting Period To: _____

This report is required by The School Board of Broward County, Florida. The prime vendor shall maintain the level of M/WBE utilization as established in the M/WBE Utilization Plan, agreement, or any subsequent amendments. The M/WBE Utilization Report shall include all Work under the contract agreement, including amendments, change orders, and work orders. Failure to comply with the M/WBE requirements of this contract agreement will be considered a material breach of contract agreement.

PRIME VENDOR INFORMATION

NAME & ADDRESS OF PRIME VENDOR:	CONTRACT AMOUNT (if applicable)	LENGTH OF CONTRACT	CONTRACT START DATE	CONTRACT END DATE	TOTAL % TO MINORITY/ WOMEN
Bid Number: 18-027B Bid Title: CAFETERIA EQUIPMENT					

M/WBE VENDOR INFORMATION

NAME OF CERTIFIED M/WBE VENDOR	WORK DESCRIPTION	M/WBE CONTRACT AMOUNT	AMOUNT PAID TO VENDOR THIS REPORTING PERIOD	TOTAL AMOUNT PAID TO DATE	% OF TOTAL PAID TO CONTRACT AMOUNT

Company Official's Signature: _____ Date: _____
 (Signature)

Printed Name: _____ Title: _____

Phone #: (____) - _____ Email: _____

THIS FORM MUST BE SUBMITTED WITH YOUR PROPOSAL

EXHIBIT B

**CERTIFICATION OF DEBARMENT, SUSPENSION, INELIGIBILITY AND VOLUNTARY EXCLUSION
LOWER TIER TRANSACTIONS**

This certification is required by the regulations implementing Executive Order 12549, Debarment and Suspension, 45 CFR 1183.35, Participants' responsibilities. The regulations were published as Part VII of the May 26, 1988 Federal Register (pages 19160-19211). Copies of the regulations may be obtained by going to this link: <http://www.gpo.gov/fdsys/granule/CFR-2011-title45-vol3/CFR-2011-title45-vol3-sec1183-35>

(BEFORE COMPLETING CERTIFICATION, READ INSTRUCTIONS ON THE NEXT PAGE)

- (1) The prospective lower tier participant certifies, by submission of this proposal, that neither it nor its principals are presently debarred, suspended, proposed for debarment, declared ineligible, or voluntarily excluded from participation in this transaction by any federal department or agency.
- (2) Where the prospective lower tier participant is unable to certify to any of the statements in this certification, such prospective participant shall attach an explanation to this proposal.

Organization Name

ITB Number

Name(s) and Title(s) of Authorized Representative(s)

Signature(s)

Date

EXHIBIT B

INSTRUCTIONS FOR CERTIFICATION

1. By signing and submitting this proposal, the prospective lower tier participant is providing the certification set out below.
2. The certification in this clause is a material representation of fact upon which reliance was placed when this transaction was entered into. If it is later determined that the prospective lower tier participant knowingly rendered an erroneous certification, in addition to other remedies available to the federal government, the department or agency with which this transaction originated may pursue available remedies, including suspension and/or debarment.
3. The prospective lower tier participant shall provide immediate written notice to the person to which this proposal is submitted if at any time the prospective lower tier participant learns that its certification was erroneous when submitted or has become erroneous by reason of changed circumstances.
4. The terms "covered transaction," "debarred," "suspended," "ineligible," "lower tier covered transaction," "participant," "person," "primary covered transaction," "principal," "proposal," and "voluntarily excluded," as used in this clause, have the meanings set out in the Definitions and Coverage sections of rules implementing Executive Order 12549. You may contact the person to which this proposal is submitted for assistance in obtaining a copy of those regulations.
5. The prospective lower tier participant agrees by submitting this proposal that, should the proposed covered transaction be entered into, it shall not knowingly enter into any lower tier covered transaction with a person who is debarred, suspended, declared ineligible, or voluntarily excluded from participation in this covered transaction, unless authorized by the department or agency with which this transaction originated.
6. The prospective lower tier participant further agrees by submitting this proposal that it will include the clause titled "Certification Regarding Debarment, Suspension, Ineligibility, and Voluntary Exclusion-Lower Tier Covered Transactions," without modification, in all lower tier covered transactions and in all solicitations for lower tier covered transactions.
7. A participant in a covered transaction may rely upon a certification of a prospective participant in a lower tier covered transaction that it is not debarred, suspended, ineligible, or voluntarily excluded from the covered transaction, unless it knows that the certification is erroneous. A participant may decide the method and frequency by which it determines the eligibility of its principals. Each participant may, but is not required to, check the Non-procurement List (Telephone Number).
8. Nothing contained in the foregoing shall be construed to require establishment of a system of records in order to render in good faith the certification required by this clause. The knowledge and information of a participant is not required to exceed that which is normally possessed by a prudent person in the ordinary course of business dealings.
9. Except for transactions authorized under paragraph 5 of these instructions, if a participant in a covered transaction knowingly enters into a lower tier covered transaction with a person who is suspended, debarred, ineligible, or voluntary excluded from participation in this transaction, in addition to other remedies available to the federal government, the department or agency with which this transaction originated may pursue available remedies, including suspension and/or debarment.

THIS EXCEL SPREADSHEET WILL CALCULATE BID LINE TOTALS FOR EACH ITEM AND GROUP TOTALS IF FILLED OUT ELECTRONICALLY AND SUBMITTED WITH THE BID PACKAGE AS AN EXCEL (.XLS) FILE. PLEASE PROVIDE PRICE PER UNIT OF MEASUREMENT INDICATED. IF WRITING IN THE INFORMATION, USE INK AND WRITE CLEARLY; CALCULATIONS WILL BE DONE DURING BID EVALUATION.

BIDDER	TYPE BIDDER'S NAME HERE
---------------	--------------------------------

Important Note:

For items in GROUPS, it is necessary to bid on EVERY ITEM IN THE GROUP and ALL ITEMS IN THE GROUP MUST MEET SPECIFICATIONS to be considered for award. If you are NOT bidding on an item, enter "NO BID" -- DO NOT LEAVE THE CELL BLANK. -- THE RESULTING "#VALUE!" TEXT IS NORMAL

Group #	Item	Description	SAP # (For SBBC Use Only)	Estimated Quantity	Unit of Measure	Price Per Unit of Measure	Total \$	Bid Line Item	Group Total
1	A	RACK, REFRIGERATOR ROLL-IN ENCLOSED NON-INSULATED	6001225	4	EACH	\$ -	\$ -	-	-
1	B	OPEN BAKERS RACK	6000129	15	EACH	\$ -	\$ -	-	-
1	C	RACK, REFRIGERATOR ROLL-IN, OPEN	6001226	10	EACH	\$ -	\$ -	\$ -	-
2		RACKS, DUNNAGE	6000084	50	EACH	\$ -	\$ -	\$ -	-
3	A	SHELF, 21" Wide X 36" Long	6001233	25	EACH	\$ -	\$ -	-	-
3	B	SHELF, 18" Wide x 36" Long	6006200	50	EACH	\$ -	\$ -	-	-
3	C	SHELF, 18" Wide x 42" Long	6006201	50	EACH	\$ -	\$ -	-	-
3	D	SHELF, 21" Wide x 42" Long	6006202	100	EACH	\$ -	\$ -	-	-
3	E	SHELF, 21" Wide X 48" Long (BR)	6000136	100	EACH	\$ -	\$ -	-	-
3	F	SHELF, 18" Wide x 48" Long	6006203	50	EACH	\$ -	\$ -	-	-
3	G	POST 63" High	6000137	100	EACH	\$ -	\$ -	-	-
3	H	POST 75"High	6004820	155	EACH	\$ -	\$ -	\$ -	-
4	A	UTILITY CART, THREE SHELVES, SMALL SIZE	6000095	130	EACH	\$ -	\$ -	-	-
4	B	UTILITY CART, THREE SHELVES, LARGE SIZE	6000096	175	EACH	\$ -	\$ -	-	-
4	C	STAND, UTILITY	6001107	5	EACH	\$ -	\$ -	\$ -	-
5	A	CART, UTILITY – SMALL	6001148	8	EACH	\$ -	\$ -	-	-
5	B	CART, UTILITY, THREE SHELVES – LARGE	6000113	10	EACH	\$ -	\$ -	-	-
5	C	CART, UTILITY, THREE SHELVES – MEDIUM	6000111	12	EACH	\$ -	\$ -	\$ -	-
6	A	TABLE, UTILITY – 5'L X 2.5'W X 3"H	6000068	60	EACH	\$ -	\$ -	-	-
6	B	TABLE, UTILITY – 6'L X 2.5'W X 3"H	6001110	50	EACH	\$ -	\$ -	\$ -	-
7	A	TABLE, WORK – STAINLESS STEEL – 60" LONG – NO CASTERS	6006281	30	EACH	\$ -	\$ -	-	-
7	B	TABLE, WORK - STAINLESS STEEL – 48" LONG – NO CASTERS	6000074	20	EACH	\$ -	\$ -	-	-
7	C	TABLE, WORK - STAINLESS STEEL – 48" LONG – WITH CASTERS	6001111	20	EACH	\$ -	\$ -	-	-

BIDDER

TYPE BIDDER'S NAME HERE

Important Note:

For items in GROUPS, it is necessary to bid on EVERY ITEM IN THE GROUP and ALL ITEMS IN THE GROUP MUST MEET SPECIFICATIONS to be considered for award.

If you are NOT bidding on an item, enter "NO BID" -- DO NOT LEAVE THE CELL BLANK. -- THE RESULTING "#VALUE!" TEXT IS NORMAL

Group #	Item	Description	SAP # (For SBBC Use Only)	Estimated Quantity	Unit of Measure	Price Per Unit of Measure	Total \$	Bid Line Item	Group Total
7	D	TABLE, WORK - STAINLESS STEEL – 60" LONG – NO CASTERS	6000075	30	EACH	\$ -	\$ -	-	
7	E	TABLE, WORK - STAINLESS STEEL – 72" LONG – NO CASTERS	6000076	20	EACH	\$ -	\$ -	-	
7	F	TABLE, WORK - STAINLESS STEEL – 84" LONG – NO CASTERS	6001112	1	EACH	\$ -	\$ -	-	
7	G	TABLE, WORK - STAINLESS STEEL – 48" LONG – WITH CASTERS	6006181	30	EACH	\$ -	\$ -	-	
7	H	TABLE, WORK - STAINLESS STEEL – 36" LONG – WITH CASTERS	6006182	30	EACH	\$ -	\$ -	-	
7	I	TABLE, WORK - STAINLESS STEEL – 42" LONG – WITH CASTERS	6006160	20	EACH	\$ -	\$ -	-	
7	J	TABLE, WORK - STAINLESS STEEL – 36" LONG – WITH CASTERS	6006161	30	EACH	\$ -	\$ -	-	
7	K	TABLE, WORK – STAINLESS STEEL – 42" LONG – NO CASTERS	6006210	20	EACH	\$ -	\$ -	-	
7	L	TABLE, WORK – STAINLESS STEEL – 60" LONG – WITH CASTERS	6000073	20	EACH	\$ -	\$ -	-	
7	M	TABLE, WORK – STAINLESS STEEL – 48" LONG – NO CASTERS	6006162	30	EACH	\$ -	\$ -	-	\$ -
8		TABLE FOR BAKER'S SCALE	6001106	4	EACH	\$ -	\$ -	-	\$ -
9	A	OVEN, STACK PIZZA CONVEYOR – 120-208 VOLT	6001079	3	UNIT	\$ -	\$ -	-	
9	B	OVEN, STACK PIZZA CONVEYOR – 480 VOLT	6002199	2	UNIT	\$ -	\$ -	-	\$ -
10	A	COOLER, MILK – 8 CRATES	6001252	10	EACH	\$ -	\$ -	-	
10	B	COOLER, MILK – 12 CRATES	6001253	10	EACH	\$ -	\$ -	-	
10	C	COOLER MILK – 16 CRATES	6001335	10	EACH	\$ -	\$ -	-	\$ -
11	A	RANGE, EXPANDO COOKING – ELECTRIC – 208 VOLT	6002182	15	EACH	\$ -	\$ -	-	
11	B	RANGE, EXPANDO COOKING – ELECTRIC – 480 VOLT	6002183	2	EACH	\$ -	\$ -	-	\$ -
12		RANGE, EXPANDO COOKING – GAS FIRED (LP OR NATURAL)	6001227	1	EACH	\$ -	\$ -	-	\$ -
13	A	KETTLE, STEAM JACKET – ELECTRIC – 208 VOLT	6000133	15	EACH	\$ -	\$ -	-	
13	B	KETTLE, STEAM JACKET – ELECTRIC – 480 VOLT	6001232	15	EACH	\$ -	\$ -	-	\$ -
14		KETTLE, STEAM JACKET – GAS FIRED – (LP OR NATURAL)	6001230	4	EACH	\$ -	\$ -	-	\$ -
15	A	REFRIGERATOR, TWO-DOOR, TWO SECTION	6000813	40	EACH	\$ -	\$ -	-	
15	B	REFRIGERATOR, THREE-DOOR, THREE SECTION	6000814	25	EACH	\$ -	\$ -	-	\$ -
16	A	CABINET, WARMING – ONE DOOR, ROLL THROUGH – 208 VOLT	6000069	8	EACH	\$ -	\$ -	-	

BIDDER

TYPE BIDDER'S NAME HERE

Important Note:
For items in GROUPS, it is necessary to bid on EVERY ITEM IN THE GROUP and ALL ITEMS IN THE GROUP MUST MEET SPECIFICATIONS to be considered for award.
If you are NOT bidding on an item, enter "NO BID" -- DO NOT LEAVE THE CELL BLANK. -- THE RESULTING "#VALUE!" TEXT IS NORMAL

Group #	Item	Description	SAP # (For SBBC Use Only)	Estimated Quantity	Unit of Measure	Price Per Unit of Measure	Total \$	Bid Line Item	Group Total
16	B	CABINET, WARMING – TWO DOOR, ROLL THROUGH – 208 VOLT	6006231	5	EACH	\$ -	\$ -	\$ -	-
17		REFRIGERATOR, TWO DOOR, ROLL-THROUGH WITH FULL DOORS	6001334	20	EACH	\$ -	\$ -	\$ -	-
18		FREEZER, REACH-IN, SELF-CONTAINED, THREE DOOR	6000810	20	EACH	\$ -	\$ -	\$ -	-
19		FREEZER, REACH-IN, SELF-CONTAINED – TWO DOOR	6000811	45	EACH	\$ -	\$ -	\$ -	-
20		WARMER, DISPLAY	6002185	10	EACH	\$ -	\$ -	\$ -	-
21		MERCHANDISER, GLASS DOOR	6000020	20	EACH	\$ -	\$ -	\$ -	-
22	A	SHELF, 18" Wide X 24" Long (QG)	6001239	4	EACH	\$ -	\$ -	-	
22	B	SHELF, 18" Wide X 30" Long (QG)	6001238	12	EACH	\$ -	\$ -	-	
22	C	SHELF, 18" Wide X 36" Long (QG)	6001234	48	EACH	\$ -	\$ -	-	
22	D	SHELF, 18" Wide X 42" Long (QG)	6000138	36	EACH	\$ -	\$ -	-	
22	E	SHELF, 18" Wide X 48" Long (QG)	6000139	100	EACH	\$ -	\$ -	-	
22	F	SHELF, 18" Wide X 54" Long (QG)	6001240	4	EACH	\$ -	\$ -	-	
22	G	SHELF, 18" Wide X 60" Long (QG)	6001236	4	EACH	\$ -	\$ -	-	
22	H	SHELF, 24" Wide X 24" Long (QG)	6001241	4	EACH	\$ -	\$ -	-	
22	I	SHELF, 24" Wide X 30" Long (QG)	6001242	12	EACH	\$ -	\$ -	-	
22	J	SHELF, 24" Wide X 36" Long (QG)	6001243	48	EACH	\$ -	\$ -	-	
22	K	SHELF, 24" Wide X 42" Long (QG)	6001244	8	EACH	\$ -	\$ -	-	
22	L	SHELF, 24" Wide X 48" Long (QG)	6001245	48	EACH	\$ -	\$ -	-	
22	M	SHELF, 24" Wide X 54" Long (QG)	6001246	4	EACH	\$ -	\$ -	-	
22	N	SHELF, 24" Wide X 60" Long (QG)	6001247	4	EACH	\$ -	\$ -	-	
22	O	POST, 63" or 64" High (QPE)	6001237	100	EACH	\$ -	\$ -	-	
22	P	POST, 72" or 74" High (QPE)	6000140	100	EACH	\$ -	\$ -	\$ -	-
23	A	WARMER, COOKER – 7 QUART	6000071	10	EACH	\$ -	\$ -	-	
23	B	WARMER, COOKER – 11 QUART	6000072	10	EACH	\$ -	\$ -	\$ -	-
24		MERCHANDISER, REFRIGERATED VERTICAL OPEN	6001076	6	EACH	\$ -	\$ -	\$ -	-

BIDDER

TYPE BIDDER'S NAME HERE

Important Note:

For items in GROUPS, it is necessary to bid on EVERY ITEM IN THE GROUP and ALL ITEMS IN THE GROUP MUST MEET SPECIFICATIONS to be considered for award.

If you are NOT bidding on an item, enter "NO BID" -- DO NOT LEAVE THE CELL BLANK. -- THE RESULTING "#VALUE!" TEXT IS NORMAL

Group #	Item	Description	SAP # (For SBBC Use Only)	Estimated Quantity	Unit of Measure	Price Per Unit of Measure	Total \$	Bid Line Item	Group Total
25		DRAWER, WARMER	6002186	2	EACH	\$ -	\$ -	\$ -	-
26	A	OVEN, DOUBLE CONVECTION – STACK, GAS FIRED (LP/NATURAL)	6000122	3	EACH	\$ -	\$ -	-	-
26	B	OVEN, CONVECTION – SINGLE SECTION, GAS FIRED – NATURAL C	6001224	4	EACH	\$ -	\$ -	\$ -	-
27	A	OVEN, CONVECTION – SINGLE SECTION, ELECTRIC FIRED	6000123	12	EACH	\$ -	\$ -	-	-
27	B	OVEN, CONVECTION – SINGLE SECTION, ELECTRIC FIRED 480V	6001221	25	EACH	\$ -	\$ -	-	-
27	C	OVEN, CONVECTION DOUBLE STACK - ELECTRIC	6001222	4	EACH	\$ -	\$ -	-	-
27	D	OVEN, CONVECTION DOUBLE STACK - ELECTRIC 480V	6001223	3	EACH	\$ -	\$ -	-	-
27	E	BOILERLESS ONE-COMPARTMENT STEAMER	6000131	8	EACH	\$ -	\$ -	-	-
27	F	CONVECTION STEAMER, TWO COMPARTMENT ELECTRIC STEAM	6000134	30	EACH	\$ -	\$ -	-	-
27	G	STEAMER, CONVECTION, TWO COMPARTMENT – GAS FIRED, NAT	6000135	5	EACH	\$ -	\$ -	\$ -	-
28	A	CART, FOOD – OUTDOOR, SECONDARY	6000097	12	EACH	\$ -	\$ -	-	-
28	B	STAND, CASHIER FOR OUTDOOR FOOD CART	6000098	15	EACH	\$ -	\$ -	-	-
28	C	CAMCART FOR FOOD PAN – CAPACITY 12 OR 16 PANS	6000114	3	EACH	\$ -	\$ -	-	-
28	D	CAMCART FOR FOOD PAN – CAPACITY 13 PANS	6000115	3	EACH	\$ -	\$ -	-	-
28	E	CART, CAMKIOSK, WITH UMBRELLA	6006233	10	EACH	\$ -	\$ -	-	-
28	F	CAMCART FOR FOOD PAN – CAPACITY 6 OR 8 PANS	6001149	3	EACH	\$ -	\$ -	-	-
28	G	CAMCART FOR FOOD PAN – CAPACITY 16 OR 24 PANS	6000091	1	EACH	\$ -	\$ -	-	-
28	H	CADDIE, ICE WITH SLIDING LID (TALL)	6000120	3	EACH	\$ -	\$ -	-	-
28	I	CABINET, HOT BULK FOOD HOLDING/TRANSPORT-LOW PROFILE	6001219	3	EACH	\$ -	\$ -	-	-
28	J	CABINET, HOT/COLD BULK FOOD HOLDING/TRANSPORT – LOW PF	6001220	1	EACH	\$ -	\$ -	\$ -	-
29	A	BAR, SALAD – FOUR PAN CAPACITY	6000085	5	EACH	\$ -	\$ -	-	-
29	B	BAR, SALAD – FIVE PAN CAPACITY	6000086	10	EACH	\$ -	\$ -	-	-
29	C	BAR, SALAD – TABLE TOP	6000087	10	EACH	\$ -	\$ -	-	-
29	D	RAIL, ACCESSORY FOR SALAD BAR – FIVE FEET	6002187	15	EACH	\$ -	\$ -	-	-
29	E	RAIL, ACCESSORY FOR SALAD BAR – SIX FEET	6002188	5	EACH	\$ -	\$ -	-	-

BIDDER

TYPE BIDDER'S NAME HERE

Important Note:
For items in GROUPS, it is necessary to bid on EVERY ITEM IN THE GROUP and ALL ITEMS IN THE GROUP MUST MEET SPECIFICATIONS to be considered for award.
If you are NOT bidding on an item, enter "NO BID" -- DO NOT LEAVE THE CELL BLANK. -- THE RESULTING "#VALUE!" TEXT IS NORMAL

Group #	Item	Description	SAP # (For SBBC Use Only)	Estimated Quantity	Unit of Measure	Price Per Unit of Measure	Total \$	Bid Line Item	Group Total
29	F	VERSA CART W/DUAL TRAY RAILS	6006234	25	EACH	\$ -	\$ -	-	
29	G	VERSA WORK TABLE - FIVE FEET	6006235	10	EACH	\$ -	\$ -	\$ -	-
30	A	TABLE, ELECTRIC HOT FOOD SERVING, OPEN BASE - 50"	6001143	1	EACH	\$ -	\$ -	-	
30	B	TABLE, ELECTRIC HOT FOOD SERVING, OPEN BASE - 60"	6001114	8	EACH	\$ -	\$ -	-	
30	C	TABLE, ELECTRIC HOT FOOD SERVING, OPEN BASE - 74"	6000099	40	EACH	\$ -	\$ -	-	
30	D	TABLE, ELECTRIC HOT FOOD SERVING, OPEN BASE - 84"	6006239	5	EACH	\$ -	\$ -	-	
30	E	TABLE, ICE COOLED COLD - OPEN BASE - 30"	6001117	6	EACH	\$ -	\$ -	-	
30	F	TABLE, ICE COOLED COLD - OPEN BASE - 36"	6001118	10	EACH	\$ -	\$ -	-	
30	G	TABLE, ICE COOLED COLD - OPEN BASE - 50-51"	6000109	50	EACH	\$ -	\$ -	-	
30	H	TABLE, ICE COOLED COLD - OPEN BASE - 60-61"	6006236	12	EACH	\$ -	\$ -	-	
30	I	TABLE, ICE COOLED COLD - OPEN BASE - 66 3/8"	6006237	12	EACH	\$ -	\$ -	-	
30	J	TABLE, ICE COOLED COLD - OPEN BASE - 74 3/8"	6006238	2	EACH	\$ -	\$ -	-	
30	K	TABLE, SOLID TOP WITH OPEN BASE - 30" (SERVING LINE)	6001122	3	EACH	\$ -	\$ -	-	
30	L	TABLE, SOLID TOP WITH OPEN BASE - 36" (SERVING LINE)	6001119	3	EACH	\$ -	\$ -	-	
30	M	TABLE, SOLID TOP WITH OPEN BASE - 42" (SERVING LINE)	6001146	2	EACH	\$ -	\$ -	-	
30	N	TABLE, SOLID TOP WITH OPEN BASE - 50" (SERVING LINE)	6000100	2	EACH	\$ -	\$ -	-	
30	O	TABLE, SOLID TOP WITH OPEN BASE - 60" (SERVING LINE)	6001120	2	EACH	\$ -	\$ -	-	
30	P	TABLE, SOLID TOP WITH OPEN BASE - 66" (SERVING LINE)	6001158	2	EACH	\$ -	\$ -	-	
30	Q	TABLE, SOLID TOP WITH OPEN BASE - 74" (SERVING LINE)	6001121	2	EACH	\$ -	\$ -	-	
30	R	SLIDE, SOLID TRAY - 28"	6000112	6	EACH	\$ -	\$ -	-	
30	S	SLIDE, SOLID TRAY - 30"	6001157	10	EACH	\$ -	\$ -	-	
30	T	SLIDE, SOLID TRAY - 36"	6001124	5	EACH	\$ -	\$ -	-	
30	U	SLIDE, SOLID TRAY - 42"	6001150	10	EACH	\$ -	\$ -	-	
30	V	SLIDE, SOLID TRAY - 50"	6000101	40	EACH	\$ -	\$ -	-	
30	W	SLIDE, SOLID TRAY - 60"	6000102	40	EACH	\$ -	\$ -	-	

BIDDER

TYPE BIDDER'S NAME HERE

Important Note:
For items in GROUPS, it is necessary to bid on EVERY ITEM IN THE GROUP and ALL ITEMS IN THE GROUP MUST MEET SPECIFICATIONS to be considered for award.
If you are NOT bidding on an item, enter "NO BID" -- DO NOT LEAVE THE CELL BLANK. -- THE RESULTING "#VALUE!" TEXT IS NORMAL

Group #	Item	Description	SAP # (For SBBC Use Only)	Estimated Quantity	Unit of Measure	Price Per Unit of Measure	Total \$	Bid Line Item	Group Total
30	X	SLIDE, SOLID TRAY – 66"	6001151	20	EACH	\$ -	\$ -	-	-
30	Y	SLIDE, SOLID TRAY – 74"	6000102	40	EACH	\$ -	\$ -	-	-
30	Z	BOARD, CUTTING – 50" (SERVING LINE)	6000116	20	EACH	\$ -	\$ -	-	-
30	AA	BOARD, CUTTING – 60" (SERVING LINE)	6001125	10	EACH	\$ -	\$ -	-	-
30	BB	BOARD, CUTTING – 74" (SERVING LINE)	6001126	40	EACH	\$ -	\$ -	-	-
30	CC	PROTECTOR, SLOPED FRONT FOOD – 50" (SERVING LINE)	6001152	10	EACH	\$ -	\$ -	-	-
30	DD	PROTECTOR, SLOPED FRONT FOOD – 60" (SERVING LINE)	6001131	20	EACH	\$ -	\$ -	-	-
30	EE	PROTECTOR, SLOPED FRONT FOOD – 74" (SERVING LINE)	6001132	3	EACH	\$ -	\$ -	-	-
30	FF	PROTECTOR, SINGLE SERVICE BUFFET, 30" (SERVING LINE)	6001153	5	EACH	\$ -	\$ -	-	-
30	GG	PROTECTOR, SINGLE SERVICE BUFFET, 36" (SERVING LINE)	6001154	2	EACH	\$ -	\$ -	-	-
30	HH	PROTECTOR, SINGLE SERVICE BUFFET, 42" (SERVING LINE)	6001133	5	EACH	\$ -	\$ -	-	-
30	II	PROTECTOR, SINGLE SERVICE BUFFET, 50" (SERVING LINE)	6001134	15	EACH	\$ -	\$ -	-	-
30	JJ	PROTECTOR, SINGLE SERVICE BUFFET, 60" (SERVING LINE)	6001135	20	EACH	\$ -	\$ -	-	-
30	KK	PROTECTOR, SINGLE SERVICE BUFFET, 66" (SERVING LINE)	6001155	10	EACH	\$ -	\$ -	-	-
30	LL	PROTECTOR, SINGLE SERVICE BUFFET, 74" (SERVING LINE)	6001136	5	EACH	\$ -	\$ -	-	-
30	MM	DISPLAY, TWO TIER – 30" (SERVING LINE)	6001156	2	EACH	\$ -	\$ -	-	-
30	NN	DISPLAY, TWO TIER – 36" (SERVING LINE)	6001127	15	EACH	\$ -	\$ -	-	-
30	OO	DISPLAY, TWO TIER – 42" (SERVING LINE)	6001147	2	EACH	\$ -	\$ -	-	-
30	PP	DISPLAY, TWO TIER – 50" (SERVING LINE)	6000104	60	EACH	\$ -	\$ -	-	-
30	QQ	DISPLAY, TWO TIER – 60" (SERVING LINE)	6000105	10	EACH	\$ -	\$ -	-	-
30	RR	DISPLAY, TWO TIER – 66" (SERVING LINE)	6001159	2	EACH	\$ -	\$ -	-	-
30	SS	DISPLAY, TWO TIER – 74" (SERVING LINE)	6000106	40	EACH	\$ -	\$ -	-	-
30	TT	STAND, THREE TIER DISPLAY 28-30" (SERVING LINE)	6001164	2	EACH	\$ -	\$ -	-	-
30	UU	STAND, THREE TIER DISPLAY 36" (SERVING LINE)	6001137	2	EACH	\$ -	\$ -	-	-
30	V V	STAND, THREE TIER DISPLAY 42" (SERVING LINE)	6001160	2	EACH	\$ -	\$ -	-	-

BIDDER

TYPE BIDDER'S NAME HERE

Important Note:

For items in GROUPS, it is necessary to bid on EVERY ITEM IN THE GROUP and ALL ITEMS IN THE GROUP MUST MEET SPECIFICATIONS to be considered for award.

If you are NOT bidding on an item, enter "NO BID" -- DO NOT LEAVE THE CELL BLANK. -- THE RESULTING "#VALUE!" TEXT IS NORMAL

Group #	Item	Description	SAP # (For SBBC Use Only)	Estimated Quantity	Unit of Measure	Price Per Unit of Measure	Total \$	Bid Line Item	Group Total
30	W W	STAND, THREE TIER DISPLAY 50" (SERVING LINE)	6001138	2	EACH	\$ -	\$ -	-	
30	XX	STAND, THREE TIER DISPLAY 60" (SERVING LINE)	6001139	2	EACH	\$ -	\$ -	-	
30	YY	STAND, THREE TIER DISPLAY 66" (SERVING LINE)	6001161	2	EACH	\$ -	\$ -	-	
30	ZZ	STAND, THREE TIER DISPLAY 74" (SERVING LINE)	6001140	2	EACH	\$ -	\$ -	-	
30	AAA	LOCKS, LINE UP – SERVING LINE	6000108	70	EACH	\$ -	\$ -	-	
30	BBB	OUTLET, CONVENIENCE – SERVING LINE	6001129	2	EACH	\$ -	\$ -	-	
30	CCC	SHELF, END DROP – SERVING LINE	6001130	3	EACH	\$ -	\$ -	-	
30	DDD	STRIP, HEAT LAMP – 60" (SERVING LINE)	6001128	5	EACH	\$ -	\$ -	-	
30	EEE	STRIP, HEAT LAMP – 74" (SERVING LINE)	6000107	40	EACH	\$ -	\$ -	-	
30	FFF	BULB, HEAT LAMP – 60" (SERVING LINE)	6001162	3	EACH	\$ -	\$ -	-	
30	GGG	BULB, HEAT LAMP – 74" (SERVING LINE)	6001163	2	EACH	\$ -	\$ -	-	
30	HHH	COLOR, CUSTOM UPGRADE – SERVING LINE	6000118	30	EACH	\$ -	\$ -	-	
30	III	FRONT, FALSE – 64" (SERVING LINE)	6001142	5	EACH	\$ -	\$ -	-	
30	JJJ	STAND, CASHIER – SERVING LINE- 28" LONG	6000110	25	EACH	\$ -	\$ -	-	
30	KKK	STAND, CASHIER – SERVING LINE - 36" LONG	6006240	25	EACH	\$ -	\$ -	-	
30	LLL	STAND, CASHIER – SERVING LINE - 42" LONG	6006241	25	EACH	\$ -	\$ -	-	
30	MMM	REFRIGERATED COLD TABLE – OPEN BASE – 50-51"	6006242	12	EACH	\$ -	\$ -	-	
30	NNN	REFRIGERATED COLD TABLE – OPEN BASE – 60-61"	6006243	12	EACH	\$ -	\$ -	-	\$ -
31	A	SCALE, DIGITAL DOUGH – HEAVY DUTY SUBMERSIBLE 10# CAPAC	6000815	50	EACH	\$ -	\$ -	-	
31	B	SCALE, DIGITAL DOUGH – HEAVY DUTY SUBMERSIBLE 20# CAPAC	6004408	30	EACH	\$ -	\$ -	-	\$ -
32		SCALE, 25 POUND PORTION	6000818	15	EACH	\$ -	\$ -	-	\$ -
33		SLICER, TWO SPEED AUTOMATIC 12"-13"	6000130	8	EACH	\$ -	\$ -	-	\$ -
34		FOOD PROCESSOR	***NEW***	15	EACH	\$ -	\$ -	-	\$ -
35	A	MIXER, 30 QUART	6001082	2	EACH	\$ -	\$ -	-	
35	B	BOWL, STAINLESS STEEL FOR 30 QUART MIXER	6001083	2	EACH	\$ -	\$ -	-	

BIDDER

TYPE BIDDER'S NAME HERE

Important Note:

For items in GROUPS, it is necessary to bid on EVERY ITEM IN THE GROUP and ALL ITEMS IN THE GROUP MUST MEET SPECIFICATIONS to be considered for award.

If you are NOT bidding on an item, enter "NO BID" -- DO NOT LEAVE THE CELL BLANK. -- THE RESULTING "#VALUE!" TEXT IS NORMAL

Group #	Item	Description	SAP # (For SBBC Use Only)	Estimated Quantity	Unit of Measure	Price Per Unit of Measure	Total \$	Bid Line Item	Group Total
35	C	BEATER, FLAT "B" FOR 30 QUART MIXER	6001084	2	EACH	\$ -	\$ -	-	
35	D	HOOK, DOUGH FOR 30 QUART MIXER	6001085	2	EACH	\$ -	\$ -	-	
35	E	WHIP, "D" WIRE LOOP FOR 30 QUART MIXER	6001086	2	EACH	\$ -	\$ -	-	
35	F	DOLLY, BOWL TRUCK FOR 30 QUART MIXER	6001087	2	EACH	\$ -	\$ -	\$ -	-
36	A	MIXER, 40 QUART	6001088	5	EACH	\$ -	\$ -	-	
36	B	BOWL, STAINLESS STEEL FOR 40 QUART MIXER	6001083	5	EACH	\$ -	\$ -	-	
36	C	BEATER, FLAT "B" FOR 40 QUART MIXER	6001090	5	EACH	\$ -	\$ -	-	
36	D	HOOK, DOUGH FOR 40 QUART MIXER	6001092	5	EACH	\$ -	\$ -	-	
36	E	WHIP, "D" WIRE LOOP FOR 40 QUART MIXER	6001091	5	EACH	\$ -	\$ -	-	
36	F	DOLLY, BOWL TRUCK FOR 40 QUART MIXER	6004630	5	EACH	\$ -	\$ -	\$ -	-
37	A	MIXER, 60 QUART	6001094	2	EACH	\$ -	\$ -	-	
37	B	BOWL, STAINLESS STEEL FOR 60 QUART MIXER	6001095	2	EACH	\$ -	\$ -	-	
37	C	BEATER, FLAT "B" FOR 60 QUART MIXER	6001096	2	EACH	\$ -	\$ -	-	
37	D	HOOK, DOUGH FOR 60 QUART MIXER	6001097	2	EACH	\$ -	\$ -	-	
37	E	WHIP, "D" WIRE LOOP FOR 60 QUART MIXER	6001098	2	EACH	\$ -	\$ -	-	
37	F	DOLLY, BOWL TRUCK FOR 60 QUART MIXER	6001099	2	EACH	\$ -	\$ -	\$ -	-
38		CABINET, NARROW WARMING – DOUBLE COMPARTMENT	6002181	20	EACH	\$ -	\$ -	\$ -	-
39		HEATED HOLDING & HUMIDIFIED CABINET – DUTCH DOORS	6006180	30	EACH	\$ -	\$ -	\$ -	-
40	A	BOILERLESS COMBI OVEN STEAMER - ELECTRIC	6006220	15	EACH	\$ -	\$ -	-	
40	B	BOILERLESS COMBI OVEN STEAMER – ELECTRIC 480V	6006221	15	EACH	\$ -	\$ -	\$ -	-
41	A	AUTOMATIC ICE MAKING MACHINE, 249 LBS. MINIMUM	6000808	30	EACH	\$ -	\$ -	-	
41	B	BIN, 360 LBS. MINIMUM	6000805	30	EACH	\$ -	\$ -	\$ -	-
42	A	AUTOMATIC ICE MAKING MACHINE, 368 LBS. MINIMUM	6000803	30	EACH	\$ -	\$ -	-	
42	B	BIN, 500 LBS. MINIMUM	6000804	30	EACH	\$ -	\$ -	\$ -	-
43	A	HOT WELL	6006204	20	EACH	\$ -	\$ -	-	

BIDDER

TYPE BIDDER'S NAME HERE

Important Note:

For items in GROUPS, it is necessary to bid on EVERY ITEM IN THE GROUP and ALL ITEMS IN THE GROUP MUST MEET SPECIFICATIONS to be considered for award.

If you are NOT bidding on an item, enter "NO BID" -- DO NOT LEAVE THE CELL BLANK. -- THE RESULTING "#VALUE!" TEXT IS NORMAL

Group #	Item	Description	SAP # (For SBBC Use Only)	Estimated Quantity	Unit of Measure	Price Per Unit of Measure	Total \$	Bid Line Item	Group Total
43	B	UTILITY COUNTER 72" x 34" x 31"	6006205	2	EACH	\$ -	\$ -	-	
43	C	ICE COLD PAN 60" x 34" x 31"	6006206	10	EACH	\$ -	\$ -	-	
43	D	CASHIER STAND 48" x 34" x 35"	6006207	5	EACH	\$ -	\$ -	-	
43	E	CASHIER STAND 40" x 34" x 35"	6006208	15	EACH	\$ -	\$ -	-	
43	F	UTILITY COUNTER 66" x 34" x 31"	***NEW***	2	EACH	\$ -	\$ -	-	
43	G	UTILITY COUNTER 60" x 34" x 31"	***NEW***	5	EACH	\$ -	\$ -	-	
43	H	UTILITY COUNTER 54" x 34" x 31"	***NEW***	15	EACH	\$ -	\$ -	-	
43	I	ICE COLD PAN 80" x 34" x 31"	***NEW***	25	EACH	\$ -	\$ -	-	
43	J	CASHIER STAND 36" x 34" x 35"	***NEW***	10	EACH	\$ -	\$ -	-	
43	K	UTILITY COUNTER 50" x 34" x 31"	***NEW***	10	EACH	\$ -	\$ -	-	\$ -
44	A	5' COOK'S TABLE W/POT RACK	6006183	40	EACH	\$ -	\$ -	-	
44	B	6' COOK'S TABLE W/POT RACK	6006184	15	EACH	\$ -	\$ -	-	\$ -
45		CONVECTION STEAMER, TWO COMPARTMENT ELECTRIC STEAM	6006261	20	EACH	\$ -	\$ -	-	\$ -
46	A	COMBITHERM, CTP7-20E, ELECTRIC 208V	6006251	5	EACH	\$ -	\$ -	-	
46	B	COMBITHERM, CTP7-20E, ELECTRIC 480V	6006252	5	EACH	\$ -	\$ -	-	
46	C	COMBITHERM, CTP10-20E, ELECTRIC, FULL SIZE 208V	6006253	15	EACH	\$ -	\$ -	-	
46	D	COMBITHERM, CTP10-20E, ELECTRIC, FULL SIZE 480V	6006254	15	EACH	\$ -	\$ -	-	\$ -
47	A	Sliding Top Milk Case Dispenser, 10 Case Min. Capacity	6006255	12	EACH	\$ -	\$ -	-	
47	B	Sliding Top Milk Case Dispenser, 6 Case Min. Capacity	6006256	2	EACH	\$ -	\$ -	-	\$ -