



THE SCHOOL BOARD OF BROWARD COUNTY, FLORIDA

7720 WEST OAKLAND PARK BOULEVARD, SUITE 323, SUNRISE, FLORIDA 33351 • TEL 754-321-0501 • FAX 754-321-0936

PROCUREMENT & WAREHOUSING SERVICES
RUBY CRENSHAW, CPPO, DIRECTOR

www.browardschools.com

SCHOOL BOARD

DONNA P. KORN, *Chair*
DR. ROSLAND OSGOOD, *Vice Chair*

ROBIN BARTLEMAN
HEATHER P.
BRINKWORTH
ABBY M. FREEDMAN
PATRICIA GOOD,
LAURIE RICH LEVINSON
ANN MURRAY
NORA RUPERT

ROBERT W. RUNCIE
Superintendent of Schools

July 16, 2015

ADDENDUM NO. 1 BID NO.:16-033B CAFETERIA EQUIPMENT

CALLED FOR 2:00 P.M. ET, JULY 21, 2015

TO ALL BIDDERS:

Amend the above referenced Bid in the following particulars only:

- | | |
|---|--|
| <p>1. DELETE: Page 32 of 157 Pages</p> <p>DELETE: Page 33 of 157 Pages</p> <p>DELETE: Page 38 of 157 Pages</p> <p>DELETE: Page 39 of 157 Pages</p> <p>DELETE: Page 40 of 157 Pages</p> <p>DELETE: Page 41 of 157 Pages</p> <p>DELETE: Page 42 of 157 Pages</p> <p>DELETE: Page 43 of 157 Pages</p> <p>DELETE: Page 44 of 157 Pages</p> <p>DELETE: Page 45 of 157 Pages</p> <p>DELETE: Page 46 of 157 Pages</p> <p>DELETE: Page 113 of 157 Pages</p> <p>DELETE: Page 115 of 157 Pages</p> | <p>INSERT: Page 32 of 157 Pages - REVISED -
(Bid Summary information has been revised)</p> <p>INSERT: Page 33 of 157 Pages - REVISED -
(Bid Summary information has been revised)</p> <p>INSERT: Page 38 of 157 Pages - REVISED -
(Bid Summary information has been revised)</p> <p>INSERT: Page 39 of 157 Pages - REVISED -
(Bid Summary information has been revised)</p> <p>INSERT: Page 40 of 157 Pages - REVISED -
(Bid Summary information has been revised)</p> <p>INSERT: Page 41 of 157 Pages - REVISED -
(Bid Summary information has been revised)</p> <p>INSERT: Page 42 of 157 Pages - REVISED -
(Bid Summary information has been revised)</p> <p>INSERT: Page 43 of 157 Pages - REVISED -
(Bid Summary information has been revised)</p> <p>INSERT: Page 44 of 157 Pages - REVISED -
(Bid Summary information has been revised)</p> <p>INSERT: Page 45 of 157 Pages - REVISED -
(Bid Summary information has been revised)</p> <p>INSERT: Page 46 of 157 Pages - REVISED -
(Bid Summary information has been revised)</p> <p>INSERT: Page 113 of 157 Pages - REVISED -
(Bid Summary information has been revised)</p> <p>INSERT: Page 115 of 157 Pages - REVISED -
(Bid Summary information has been revised)</p> |
|---|--|

This Addendum is for informational purposes only and need not be returned with your bid. By virtue of signing the "Invitation to Bid form 3270D," Page 1 of Bid No. 16-033B, Bidder certifies acceptance of this Addendum.

Respectfully,

Bernadette Green, MPA
Procurement and Warehousing Servi

The School Board of Broward County, Florida
CAFETERIA EQUIPMENT

SECTION 5, BID SUMMARY SHEET

ITEM 10: (TO BE AWARDED AS A GROUP)

A. 20 each SAP #6001252 \$ _____ /ea \$ _____

COOLER, MILK – 8 CRATES

Drop front style cooler, all stainless steel Type 300 stainless front, top, sides, doors and interior. Storage capacity 8 crates (13" x 13" x 11"). Stainless steel floor on top of minimum of 18 gauge galvanized steel with heavy-duty floor rack. Foamed-in-place polyurethane minimum 1-5/8" high-density insulated door. Self contained refrigeration system, no plumbing required. 4" – 5" heavy-duty swivel casters, 2 with brakes. Cylinder lock or pad lock for security. Nema 5-15P cord/cap, minimum cord length 8 feet. **NSF and UL approved. Warranty: Two year manufacturer's warranty, all parts and labor, 5 years on compressor must be included in unit price.** Price must include inside delivery and complete operational setup.

Approved Brands: True Mfg. Model TMC-34-S-SS with s/s interior, Mod-U-Serve Model MCT-SM1, Norlake Model ARO82SSSS/O, Beverage Air Model SMF34-S ONLY.

Brand Offered: _____

Model Offered: _____

Warranty Period: _____

Delivery (days ARO): _____

B. 20 each SAP #6001253 \$ _____ /ea \$ _____

COOLER, MILK – 12 CRATES

Drop front style cooler, all stainless steel Type 300 stainless front, top, sides, doors and interior. Storage capacity 12 crates (13" x 13" x 11"). Stainless steel floor on top of minimum of 18 gauge galvanized steel with heavy-duty floor rack. Foamed-in-place polyurethane minimum 1-5/8" high-density insulated door. Self contained refrigeration system, no plumbing required. 4" – 5" heavy-duty swivel casters, 2 with brakes. Cylinder lock or pad lock for security. Nema 5-15P cord/cap, minimum cord length 8 feet. **NSF and UL approved. Warranty: Two year manufacturer's warranty, all parts and labor, 5 years on compressor must be included in unit price.** Price must include inside delivery and complete operational setup.

Approved Brands: True Mfg. Model TMC-49-S-SS with s/s interior, Mod-U-Serve Model MCT-SM2, Norlake Model ARO122SSSS/O, Beverage Air Model SMF49-S ONLY.

Brand Offered: _____

Model Offered: _____

Warranty Period: _____

Delivery (days ARO): _____

VENDOR NAME: _____

BNG

The School Board of Broward County, Florida
CAFETERIA EQUIPMENT

SECTION 5, BID SUMMARY SHEET (Continued)

			<u>UNIT PRICE</u>	<u>TOTAL COST</u>
ITEM 10:		(TO BE AWARDED AS A GROUP) – Continued		
C.	5 each	SAP #6001335 COOLER MILK – 16 CRATES Drop front style cooler, all stainless steel Type 300 stainless front, top, sides, doors and interior. Storage capacity 16 crates (13" x 13" x 11"). Stainless steel floor on top of minimum of 18 gauge galvanized steel with heavy-duty floor rack. Foamed-in-place polyurethane minimum 1-5/8" high-density insulated door. Self-contained refrigeration system, no plumbing required. 4" – 5" heavy-duty swivel casters, 2 with brakes. Cylinder lock or pad lock for security. Nema 5-15P cord/cap, minimum cord length 8 feet. NSF and UL approved. Warranty: Two year manufacturer's warranty, all parts and labor, 5 years on compressor must be included in the unit price. Price must include inside delivery and complete operational setup. Approved Brands: True Mfg. Model TMC-58-S-SS with s/s interior, Mod-U-Serve Model MCT-SM3, Norlake Model ARO162SSS/O, Beverage Air Model SMF58-S Brand Offered: _____ Model Offered: _____ Warranty Period: _____ Delivery (days ARO): _____	\$ _____	/ea \$ _____
TOTAL BID ITEM 10 (A – C inclusive).....			\$ _____	

VENDOR NAME: _____
BNG

The School Board of Broward County, Florida
CAFETERIA EQUIPMENT

SECTION 5, BID SUMMARY SHEET

<u>ITEM 15:</u>	<u>(TO BE AWARDED AS A GROUP)</u>	<u>UNIT PRICE</u>	<u>TOTAL COST</u>
A.	40 each	SAP #6000813	
		\$ _____	/ea \$ _____

REFRIGERATOR, TWO-DOOR, TWO SECTION
Construction to be stainless steel exterior door, front, sides, & interior floor. Aluminum interior side walls and back. 20 gauge stainless steel door & door interior. Foamed-in-Place Polyurethane Insulation throughout. Front shroud to lift up for easy access to clean condenser coil. Refrigeration to be R-134a or R290 where available. Top mount refrigeration system. All-in-one SIMPLE controller with maximum of 4 parameters that is pre-programmed from the factory. Four sensors on front controller to include temp setting, manual defrost, and lockout. Exterior digital temperature display; automatic LED lighting with door switch. Durable removable snap-in magnetic gasket. Self-closing door with stay open feature. Lifetime guarantee on ergonomic door handle and cam-lift door hinges. Heavy duty cylinder or bolt locks with lifetime warranty. One door to have three (3) heavy-duty, epoxy coated or chrome shelves. One door complete with a minimum of 12 sets of universal tray/pan slides on 4" centers to accept bottom support 18" x 26" pans and 12" x 20" pans. All condensate water is disposed of automatically by the energy efficient, non-electric condensate evaporator. Condenser coil to be out of food zone. If expansion valve system Compressor to have high-pressure cut-off switch. If a capillary tube system then system must be oversized and balanced for quick recovery and pull down. Maintains temperatures of 33 degrees – 38 degrees. Inside storage capacity to be a minimum of 46 useable cubic feet. Heavy-duty 5" polyurethane plate casters, two with brakes. Size: Maximum height 84-1/4" on wheels, depth 35", length 52-53". 115V/60Hz/1 phase, amp draw not to exceed 11.0 with 9' or 10' Nema 5-15P cord/cap. NSF and UL approved.
Warranty: Three year manufacturer's warranty, all parts and labor, five years for compressor must be included in the unit price. Warranty on compressor to be completely handled by service company for 5 years. Price to include uncrate, set in place, removal of cartons, installation of shelves and clips, pan slides and casters, plug in and make ready for use. Must ship from factory within 4 weeks of receipt of purchase order.
Approved Brand: Victory Model RSA-2D-S1, TRUE STA2R-2S with 2 each #3 accessory kits for 1 door or other brands meeting bid specifications

Brand Offered: _____
Model Offered: _____
Warranty Period: _____
Delivery (days ARO): _____

VENDOR NAME: _____
BNG

The School Board of Broward County, Florida
CAFETERIA EQUIPMENT

SECTION 5, BID SUMMARY SHEET (Continued)

		<u>UNIT PRICE</u>	<u>TOTAL COST</u>
ITEM 15:	(TO BE AWARDED AS A GROUP) – Continued		
B.	25 each SAP #6000814	\$ _____	/ea \$ _____
	<p>REFRIGERATOR, THREE-DOOR, THREE SECTION Construction to be stainless steel exterior door, front, sides, & interior floor. Aluminum interior side walls and back. 20 gauge stainless steel door & door interior liner. Front shroud to lift up for easy access to clean condenser coil. Refrigeration to be R-134a or R290 where available, foamed-in-place polyurethane insulation throughout. Top mount refrigeration system. All-in-one SIMPLE controller with maximum of 4 parameters that is pre-programmed from the factory. Four sensors on front controller to include temp. setting, manual defrost, and lockout. Exterior digital temperature display; automatic LED interior light with door switch. Durable removable magnetic snap-in gasket with 2 year warranty. Self-closing door with stay open feature. Lifetime guarantee on ergonomic door handle and cam-lift door hinges. Heavy duty cylinder or bolt locks with lifetime warranty. Two doors to have three (3) heavy-duty, epoxy coated or chrome shelves. One door complete with a minimum of 12 sets of universal tray/pan slides on 4" centers to accept bottom support 18" x 26" pans and 12" x 20" pans. All condensate water is disposed of automatically by the energy efficient, non-electric condensate evaporator. Condenser coil to be out of food zone. If expansion valve system, Compressor to have high-pressure cut-off switch. If a capillary tube system, then system must be oversized and balanced for quick recovery and pull down. Inside storage capacity to be a minimum of 70.09 useable cubic feet. Refrigerator to include the following options: heavy-duty 5" polyurethane plate casters, two with brakes, Maximum height 84-1/4" on casters, max. depth 35". Length 76-78". 115V/60Hz/1 phase, amp draw not to exceed 11.0 with 9' or 10' Nema 5-15P cord/cap. <u>NSF and UL approved.</u> Warranty: Three year manufacturer's warranty, five years for compressor must be included in the unit price. Warranty on compressor to be completely handled by service company for 5 years. Price to include uncrate, set in place, removal of plastic and cartons, installation of shelves and clips, plug in, and make ready for use. Must ship from factory within 4 weeks of receipt of purchase order. Approved Brands: Victory Model RSA-3D-S1, TRUE STA3R-3S with 2 each #3 accessory kits for 1 door or other brands meeting bid specifications</p>		
	Brand Offered: _____ Model Offered: _____ Warranty Period: _____ Delivery (days ARO): _____		
	TOTAL BID ITEM 15 (A – B inclusive).....	\$ _____	

VENDOR NAME: _____
 BNG

The School Board of Broward County, Florida
CAFETERIA EQUIPMENT

SECTION 5, BID SUMMARY SHEET (Continued)

		<u>UNIT PRICE</u>	<u>TOTAL COST</u>
ITEM 16:	<u>(TO BE AWARDED AS A GROUP)</u>		
A.	20 each SAP #6000069 CABINET, WARMING – ONE DOOR, ROLL THROUGH – 208 VOLT Cabinet insulation to be polyurethane foam. Construction to be stainless exterior and aluminum interior with stainless steel floor and s/s ramps. 20 gauge stainless steel door & door interior line. Front shroud to lift up for easy access to clean condenser coil. Foamed in place polyurethane insulation. Durable removable magnetic snap-in gasket with 2 year warranty. Self-closing door with stay open feature. Lifetime guarantee on ergonomic door handle and cam-lift door hinges. Heavy duty cylinder or bolt locks with lifetime warranty. Clear inside door openings to be minimum of 27-1/4" wide x 66-1/4" high allowing use of 27" wide x 29" deep x 64.5" high mobile racks. Rack offered must fit inside cabinet. Furnish with UL approved automatic 1500 watt heating system. 115/208/240/60/1 or 208/60/1. Include power indicator light, and digital thermometer. Unit is to be National Sanitary Foundation (NSF) and Underwriter's Laboratories (UL) approved. To include one fully welded rack of structural aluminum designed for fit in pass-through warmers. Rack must have 18 extruded angle ledge to hold bottom of pan with heavy duty 5" plate casters, 2 with brakes. Warranty: Three year manufacturer's warranty on all parts and labor must be included in the unit price. Price to include set up which includes uncrate, set in place, removal of plastic on unit and removal of cartons. Vendor responsible for leveling cabinet and caulking or sealing to floor where necessary. Wheels of rack must fit inside door with door closed. Installation of unit must be leveled and shimmed if necessary and sealed to the floor. Approved Brands: Victory Model HISA-1D-1-PT , True Model STA1HRT-1S-1S with Rack – Crescor Model 207-1818C or New Age Model 1335 or other brands meeting bid specifications	\$ _____	/ea \$ _____
	Brand Offered: _____		
	Model Offered: _____		
	Rack Offered: _____		
	Warranty Period: _____		
	Delivery (days ARO): _____		

VENDOR NAME: _____
BNG

The School Board of Broward County, Florida
CAFETERIA EQUIPMENT

SECTION 5, BID SUMMARY SHEET (Continued)

		<u>UNIT PRICE</u>	<u>TOTAL COST</u>
ITEM 16:	(TO BE AWARDED AS A GROUP)		
B. 5 each	SAP # _____ CABINET, WARMING – TWO DOOR, ROLL THROUGH – 208 VOLT Cabinet insulation to be polyurethane foam. Construction to be stainless exterior and aluminum interior with stainless steel floor and s/s ramps. 20 gauge stainless steel door & door interior line. Front shroud to lift up for easy access to clean condenser coil. Foamed in place polyurethane insulation. Durable removable magnetic snap-in gasket with 2 year warranty. Self-closing door with stay open feature. Lifetime guarantee on ergonomic door handle and cam-lift door hinges. Heavy duty cylinder or bolt locks with lifetime warranty. Height not to exceed 84 1/4" to fit in wall cut-out. Clear inside door openings to be minimum of 27 1/4" wide x 66 1/4" high allowing use 27" wide x 29" deep x 64.5" high mobile racks. To include 2 each fully welded racks of structural aluminum designed for fit in pass-through warmers. Rack must have 18 extruded angle ledge to hold bottom of pan with heavy duty 5" plate casters, 2 with brakes. Furnish with UL approved automatic 1500 watt heating system. 115/208-240/60 or 208/60/1. Include power indicator light and digital thermometer. Unit is to be National Sanitary Foundation (NSF) and Underwriter's Laboratories (UL) approved. Warranty: Three year manufacturer's warranty on all parts and labor must be included in the unit price. Price to include set up which includes uncrate, set in place, removal of plastic on unit and removal of cartons. Vendor responsible for leveling cabinet. Wheels of rack must fit inside door with door closed. Installation of unit must be leveled and shimmed if necessary and sealed to the floor. Approved Brands: Victory Mode HISA-2D-1PT, True Model STA2HRT-2S-2S with Rack – Crescor Model 207-1818C or New Age Model 1335 or other brands meeting bid specifications Brand Offered: _____ Model Offered: _____ Rack Offered: _____ Warranty Period: _____ Delivery (days ARO): _____	\$ _____	/ea \$ _____

TOTAL BID ITEM 16 (A – B inclusive).....\$ _____

VENDOR NAME: _____
 BNG

The School Board of Broward County, Florida
CAFETERIA EQUIPMENT

SECTION 5, BID SUMMARY SHEET (Continued)

<u>ITEM 17:</u>			<u>UNIT PRICE</u>	<u>TOTAL COST</u>
20 each	SAP #6001334 REFRIGERATOR, TWO DOOR, ROLL-THROUGH WITH FULL DOORS	Two-door roll-through refrigerator with full doors. Construction to be stainless steel exterior and aluminum interior with stainless steel floor and s/s ramps. 20 gauge stainless steel door & door interior liner. Foamed in place polyurethane insulation. Refrigeration to be R-134A or R290 where available. Durable removable magnetic snap-in gasket with. Self-closing door with stay open feature. Lifetime guarantee on ergonomic door handle and cam-lift door hinges. Heavy duty cylinder or bolt locks with lifetime warranty. Each door opening accepts mobile storage rack 27" w x 29" d x 64.5" high. All-in-one SIMPLE controller with maximum of 4 parameters that are pre-programmed from the factory. Four sensors on front controller to include temp. setting, manual defrost and lockout. Exterior digital temperature display; automatic LED interior light with door switch. All condensate water is disposed of automatically by the energy efficient, non-electric condensate evaporator. No plumbing required. Power supply at top. Provide evaporator coil out of food zone. Condensing unit top mounted, air-cooled. If a capillary tube system, then system must be oversized and balanced for quick recovery and pull down. Maximum height of 84 - 1/4", max. depth 36 5/8", and length 68"-69". Voltage to be 115/60/1 with 1/2 - 3/4 H.P. Compressor. Amp draw not to exceed 11.0 with 9' or 10' Nema 5-15P cord/cap. Upper end panels shall be removable allowing accessibility for service from front or sides. Unit is to be National Sanitary Foundation (NSF) and Underwriter's Laboratories (UL) listed. Warranty: Three year manufacturer's warranty on all parts and labor with warranty, five years on compressor must be included in the unit price. Awardee must provide parts list, service manual, and schematics with each delivered unit. Ship with UL approved six-foot cord and plug set. Furnish with two roll-in racks all welded construction w/stem casters and universal pan slides. Set up includes uncrate, set in place, removal of cartons and removal of plastic on unit. Unit must be leveled and shimmed if necessary unit to be sealed to the floor. Bidder is responsible for leveling unit and caulk around perimeter to seal to floor, and verifying clearance of all doors leading to kitchen. Approved Brands: REFRIGERATOR - Victory Model RISA-2D-S1-PT 7 or TRUE STA2RRT-2S-2S with RACKS - Crescor Model 207-1818C or New Age Model 1335 or other brands meeting bid specifications.	\$ _____	/ea \$ _____
	Brand Offered: _____	Model Offered: _____	Rack Offered: _____	Warranty Period: _____
	Delivery (days ARO): _____			

VENDOR NAME: _____

BNG

The School Board of Broward County, Florida
CAFETERIA EQUIPMENT

SECTION 5, BID SUMMARY SHEET (Continued)

<u>ITEM 18:</u>	<u>5 each</u>	<u>SAP #6000812</u>	<u>UNIT PRICE</u>	<u>TOTAL COST</u>
		REFRIGERATOR, TWO DOOR, ROLL-IN WITH FULL DOORS Two-door roll-in refrigerator with full doors, stainless steel exterior and aluminum interior with stainless steel floor and s/s ramps. 20 gauge stainless steel door & door interior liner. Foamed in place polyurethane insulation. Refrigeration to be R-134a or R290 where available. Durable removable magnetic snap-in gasket. Self-closing door with stay open feature. Lifetime guarantee on ergonomic door handle and cam-lift door hinges. Heavy duty cylinder or bolt locks with lifetime warranty. Each door opening accepts mobile storage rack 27" w x 29" d x 64.5" high. All-in-one SIMPLE controller with maximum of 4 parameters that are pre-programmed from the factory. Four sensors on front controller to include temp. setting, manual defrost, and lockout. Exterior digital temperature display; automatic LED interior light with door switch. All condensate water is disposed of automatically by the energy efficient, non-electric condensate evaporator. Power supply at top. No plumbing required. Provide evaporator coil out of food zone. Condensing unit top mounted, air-cooled, expansion valve system or capillary tube system that is oversized and balanced for quick recovery and pull down. Maximum height of 84-1/4", max. depth 36 5/8", and length 68"-69". Voltage to be 115/60/1 with 1/2 - 3/4 h.p. compressor. Amp draw not to exceed 11.0 with 9' or 10' Nema 5-15P cord/cap. Upper end panels shall be removable allowing accessibility for service from front and sides. Unit is to be NSF and UL listed, and energy star rated. Warranty: Three manufacturer's year warranty on all parts and labor with five year on compressor must be included in the unit price. <u>Awardee must provide parts list, service manual, and schematics with each delivered unit. Ship with UL approved six-foot cord and plug set. Furnish with two roll-in racks all welded construction w/stem casters and universal pan slides.</u> Set up includes uncrate, set in place, removal of cartons and removal of plastic on unit. Bidder is responsible for leveling unit and caulk around perimeter to seal to floor, and verifying clearance of all doors leadings to kitchen. Approved Brand: REFRIGERATOR – Victory Model RISA-2D-S1 or TRUE STARRI-2S with RACKS – Crescor Model 207-1818C or New Age Model 1335 or other brands meeting bid specifications	\$ _____	/ea \$ _____

Brand Offered: _____
 Model Offered: _____
 Rack Offered: _____
 Warranty Period: _____
 Delivery (days ARO): _____

VENDOR NAME: _____
 BNG

The School Board of Broward County, Florida
CAFETERIA EQUIPMENT

SECTION 5, BID SUMMARY SHEET (Continued)

			<u>UNIT PRICE</u>	<u>TOTAL COST</u>
ITEM 19:	20 each	SAP #6000810 FREEZER, REACH-IN, SELF-CONTAINED, THREE DOOR Freezer construction to be stainless steel exterior door, front, sides, & interior floor. Aluminum interior side walls and back. 20 gauge stainless steel door. Unit must have reinforced bottom to withstand heavy loads. Foamed-in-Place Polyurethane Insulation throughout. Front shroud to lift up for easy access to clean condenser coil. Maintains temperatures of -5 degrees. Refrigeration to be R-404a or R290 where available. Top mount refrigeration system with expansion valve. Capacity: minimum 70 cu. ft. of usable space. Heavy duty 5" polyurethane plate casters, 2 with brakes. Each compartment shall have a chrome or stainless steel floor rack. Self-closing door with stay open feature. Lifetime guarantee on ergonomic door handle and cam-lift hinges. Heavy duty cylinder or bolt locks with lifetime warranty. All-in-one SIMPLE controller with maximum of 4 parameters that is pre-programmed from the factory. Four sensors on front controller to include temp. setting, manual defrost, and lockout. Exterior digital temperature display; automatic LED lighting with door switch. Durable removable magnetic snap-in gasket. Anti-condensate door perimeter heaters. Non-electric condensate evaporator top mounted that disposes of water automatically with pan of sufficient size to accommodate condensation. No plumbing required. Power supply at top. Provide evaporator coil out of food zone. Furnished with nine heavy-duty epoxy coated or chrome shelves, three per door to accommodate 18" x 26" sheet pans in each full door. Size: Maximum height 84-1/4" high, max. depth 35", length 76 - 78". Electrical: 208/-230/60/1, not to exceed 14.0 AMPS. Condensing unit 3/4 HP. Unit to be NSF and UL listed. Warranty: Three year manufacturer's warranty on all parts and labor plus warranty against condensation build up, five year warranty parts and labor on compressor must be included in the unit price. Warranty on compressor to include shipping and pick up of old compressor upon phone call to factory. Set-up will include installation of shelves and clips and installation of wheels. Uncrated and remove crate. Unit must be shipped with parts manual and schematics to each location. Approved Brand: Victory Model FSA-3D-S1 or other brands meeting bid specifications Brand Offered: _____ Model Offered: _____ Warranty Period: _____ Delivery (days ARO): _____	\$ _____	/ea \$ _____

VENDOR NAME: _____
 BNG

The School Board of Broward County, Florida
CAFETERIA EQUIPMENT

SECTION 5, BID SUMMARY SHEET (Continued)

<u>ITEM 20:</u>	<u>45 each</u>	<u>SAP #6000811</u>	<u>UNIT PRICE</u>	<u>TOTAL COST</u>
		<p>FREEZER, REACH-IN, SELF-CONTAINED – TWO DOOR</p> <p>Freezer construction to be stainless steel exterior door, front, sides, & interior floor. 20 gauge stainless steel door. Unit must have reinforced bottom to withstand heavy loads. Aluminum interior side walls and back. Foamed-in-Place Polyurethane Insulation throughout. Front shroud to lift up for easy access to clean condenser coil. Maintains temperatures of -5 degrees. Refrigeration to be R-404a or R290 where available. Top mount refrigeration system with expansion valve. Capacity: minimum 46.5 cu. ft. of usable space. Heavy duty 5" polyurethane plate casters, 2 with brakes. Each compartment shall have a chrome floor rack.</p> <p>Self-closing door with stay open feature. Lifetime guarantee on ergonomic door handle and cam-lift hinges. Heavy duty cylinder or bolt locks with lifetime warranty, all doors keyed alike. All-in-one SIMPLE controller with maximum of 4 parameters that is pre-programmed from the factory. Four sensors on front controller to include temp. setting, manual defrost, and lockout. Exterior digital temperature display; automatic LED lighting with door switch. Durable removable magnetic snap-in gasket. Breaker strips shall leave no exposed electrical heating elements and securely installed around entire perimeter of front frame and mullions of all door openings.</p> <p>Non-electric condensate evaporator top mounted that disposes of water automatically with pan of sufficient size to accommodate condensation. No plumbing required. Power supply at top. Provide evaporator coil out of food zone.</p> <p>Furnish with six heavy-duty epoxy coated or chrome shelves, to-accommodate 18" x 26" pans, three per door. Size: Maximum height 84-1/4" high on wheels, max. depth 35", length 52 – 53". Electrical: 115/60/1, not to exceed 12 AMPS. ½ or ¾ HP condensing unit. Unit to be NSF and UL listed.</p> <p>Warranty: Three year manufacturer's warranty on all parts and labor plus warranty against condensation build up, five year warranty on compressor must be included in the unit price. Set-up will include installation of shelves and clips and installation of wheels. Uncrate, set-in place, remove all cartons. Unit must be shipped with parts manual and schematics to each location.</p> <p>Approved Brands: Victory Model FSA-2D-S1 or other brands meeting bid specifications</p> <p>Brand Offered: _____</p> <p>Model Offered: _____</p> <p>Warranty Period: _____</p> <p>Delivery (days ARO): _____</p>	\$ _____	/ea \$ _____

VENDOR NAME: _____
BNG

The School Board of Broward County, Florida
CAFETERIA EQUIPMENT

SECTION 5, BID SUMMARY SHEET (Continued)

		<u>UNIT PRICE</u>	<u>TOTAL COST</u>
ITEM 21:	10 each SAP #6002185 WARMER, DISPLAY Adjustable display warmer with two-bulb reflectors and display base that accepts 12" x 20" steam table pans. Warmer to be 19-1/4" long x 13" wide x 28-1/4" high, with 6" wide bulb holder and 11-3/4" - 19-3/4" adjustable clearance between bottom of reflector and base. 120 volt, 500 watt with two 250W infrared bulbs included. Reflectors to be stainless steel, vented at the top, capable of holding one 250W bulb. On/off switch and six foot cord and plug included. <u>To be delivered completely assembled.</u> Manufacturer's standard warranty will apply. Approved Brands: American Permanent Ware Model DW-1A, Nemco Model 6000A-2 or other brands meeting bid specifications Brand Offered: _____ Model Offered: _____ Warranty Period: _____ Delivery (days ARO): _____	\$ _____	/ea \$ _____

ITEM 22:	10 each SAP #6000020 MERCHANDISER, GLASS DOOR Factory engineered self-contained and energy efficient refrigeration system, – interior temperature holds 33 degrees F to 38 degrees F. If cap tube system, extra-large evaporator with higher horsepower compressor. Condensing unit positioned for easy maintenance. Self-lubricating evaporator fan motor(s) and larger fan blades for high volume air flow or equivalent to pull down warm product faster. Exterior to be non-peel or chip black or white laminated vinyl. Interior white aluminum with stainless steel floor. Entire cabinet insulated with foamed-in-place high density polyurethane insulation with zero ozone depletion potential. Door to have double pane thermal insulated glass with extruded alumina frame or equivalent. Positive seal closure with one piece magnetic door gasket without use of tools. LED lighting in interior w/ safety shield. To have four adjustable heavy-duty wire shelves with four clips per shelf. Approx. dimensions 27" w x 30" d x 78 5/8" h. Height not to exceed 80". Pre-wired at factory and ready for final connection to a 115/60/1 phase, 15 amp dedicated outlet. Nema 5-15R cord and plug set included. Provide with factory installed lock. Warranty: Three years manufacturer's warranty, all parts and labor with two extra years warranty on compressor. Price must include freight, inside delivery and complete operational setup. Approved Brands: True Model GDM-23-HC-LD w/ optional barrel lock or other brands meeting bid specifications Brand Offered: _____ Model Offered: _____ Warranty Period: _____ Delivery (days ARO): _____	<u>UNIT PRICE</u> \$ _____	<u>TOTAL COST</u> /ea \$ _____
-----------------	--	-------------------------------	-----------------------------------

VENDOR NAME: _____
BNG

The School Board of Broward County, Florida
CAFETERIA EQUIPMENT

SECTION 5, BID SUMMARY SHEET (Continued)

		<u>UNIT PRICE</u>	<u>TOTAL COST</u>
ITEM 37: (TO BE AWARDED AS A GROUP)			
A.	5 each	\$ _____	/ea \$ _____
	<p>SAP #6001088 MIXER, 40 QUART 1-1/2 H.P. or 2 H.P. (minimum), electrical 208/60/1, single phase or 3-phase floor model, three-speed mixer or variable speed with thermal overload protection. Bowl-lift hand operated, self-locking in up or down position with bowl height sensing. Three positive speeds; low, intermediate and high. Gear driven constant mesh transmission or variable speed belt drive. Motor to have permanently lubricated anti-friction ball bearings. Unit to be gray polyurethane enamel or powder coat on top of corrosion resistant primer. To be equipped with a 15 minute (minimum) timed mixing control which automatically shuts off machine in any speed after set time has elapsed. Stainless steel wire bowl guard. Guard lifts or swings to disengage motor. "Start - Stop" push buttons. Smooth finish, no hard to clean projections or crevices. <u>Stainless steel feet or PVC feet pads, or rubber feet installed to prevent rust. Required Equipment: (1) 40-quart stainless steel bowl, (1) "B" flat beater, (1) "D" wire whip, (1) dough hook and stainless steel bowl guard or stainless steel screen, cord and plug must be shipped with order and included into the unit price. NSF and U.L. listed. Warranty: Two year manufacturer's warranty, all parts and labor, must be included in the unit price. Inside delivery and set-up required</u> Approved Brands: Hobart Model HL400, Varimixer Model W40A, Globe Model SP40 ONLY.</p> <p>Brand Offered: _____ Model Offered: _____ Warranty Period: _____ Delivery (days ARO): _____</p>		
B.	5 each	\$ _____	/ea \$ _____
	<p>SAP #6001083 BOWL, STAINLESS STEEL FOR 40 QUART MIXER Must be compatible and be the same brand as Item 37A. Approved Brands: Hobart, Varimixer, Globe ONLY. Brand Offered: _____ Model Offered: _____ Warranty Period: _____ Delivery (days ARO): _____</p>		

VENDOR NAME: _____
 BNG

The School Board of Broward County, Florida
CAFETERIA EQUIPMENT

SECTION 5, BID SUMMARY SHEET (Continued)

			<u>UNIT PRICE</u>	<u>TOTAL COST</u>
ITEM 38:		(TO BE AWARDED AS A GROUP)		
A.	2 each	SAP #6001094 MIXER, 60 QUART 2.7 H.P. (minimum), electrical (208/60/3 or 1) single phase or three phase, floor model, three to four speed mixer, or variable speed mixer with thermal overload protection. Transmission for unit to be gear driven, constant mesh or variable speed belt drive. Motor to have permanently lubricated ball bearings and totally enclosed motor. Stainless steel wire bowl guard. Guard disengages motor to lift or swing open. Unit to be gray polyurethane enamel on top of corrosion resistant primer. To be equipped with a 15 minute (minimum) timed mixing control which automatically shuts off machine in any speed after set time has elapsed. "Start - Stop" push buttons. <u>Stainless steel feet or PVC feet pads, or rubber feet installed to prevent rust.</u> Smooth finish, no hard to clean projections or crevices. <u>Standard Accessory Package: (1) 60-quart stainless steel bowl, (1) "B" flat beater, (1) "D" wire whip, (1) dough hook and stainless steel bowl guard or stainless steel screen, cord and plug must be shipped with order and be included into the unit price.</u> NSF and U.L. Approved/Listed. Warranty: Two year manufacturer's warranty, all parts and labor, must be included in the unit price. Inside delivery and set-up required Approved Brands: Hobart Model HL-600, Varimixer Model W60A, Globe Model SP60 ONLY. Brand Offered: _____ Model Offered: _____ Warranty Period: _____ Delivery (days ARO): _____	\$ _____	/ea \$ _____
B.	2 each	SAP #6001095 BOWL, STAINLESS STEEL FOR 60 QUART MIXER Must be compatible and be the same brand as Item 38A. Approved Brands: Hobart, Varimixer, Globe ONLY. Brand Offered: _____ Model Offered: _____ Warranty Period: _____ Delivery (days ARO): _____	\$ _____	/ea \$ _____

VENDOR NAME: _____
BNG



THE SCHOOL BOARD OF BROWARD COUNTY, FLORIDA

7720 WEST OAKLAND PARK BOULEVARD, SUITE 323, SUNRISE, FLORIDA 33351 • TEL 754-321-0501 • FAX 754-754-0936

PROCUREMENT & WAREHOUSING SERVICES
RUBY CRENSHAW, CPPO, DIRECTOR
www.browardschools.com

SCHOOL BOARD
DONNA P. KORN, *Chair*
DR. ROSLAND OSGOOD, *Vice Chair*

June 17, 2015

ROBIN BARTLEMAN
HEATHER P.
BRINKWORTH
ABBY M. FREEDMAN
PATRICIA GOOD,
LAURIE RICH LEVINSON
ANN MURRAY
NORA RUPERT

ROBERT W. RUNCIE
Superintendent of Schools

Dear Prospective Bidders:

**SUBJECT: Instructions to Bidders
Invitation to Bid - 16-033B, Cafeteria Equipment**

The School Board of Broward County, Florida (SBBC) is interested in receiving bids in response to the attached Invitation to Bid (ITB) for **Cafeteria Equipment**. Any questions regarding this ITB should be addressed to me, in writing, at the address stated above, via facsimile at 754-321-0533 or via e-mail to Bernadette.Green@browardschools.com. No other School Board staff member should be contacted in relation to this ITB. Any information that amends any portion of this ITB, which is received by any method other than an Addendum issued to the ITB, is not binding on SBBC.

In order to assure that your bid is in full compliance with all requirements of the ITB, carefully read all portions of the ITB document, paying particular attention to the following areas:

• **M/WBE CERTIFICATION/PARTICIPATION – SEE EXHIBIT A**

SBBC has implemented a Minority/Women Business Enterprise Program as part of the SBBC's competitive solicitation and contracting activity in accordance with School Board Policy 7007-A Administrative Procedures for The School Board of Broward County, Florida's Supplier Diversity & Outreach Program. The purpose of the program is to utilize available minority and women business enterprises (M/WBEs) within the Board's market area to compete for the award of SBBC purchasing contracts. M/WBE vendors utilized for this contract must be certified by SBBC, Supplier Diversity & Outreach Program Office. **For information on M/WBE Certification, contact SBBC's Supplier Diversity & Outreach Program at 754-321-0550.**

• **SECTION 2, SUBMITTAL REQUIREMENTS**

Section 2, Submittal Requirements, is a listing of all submittals that are required to be part of your bid package. Please make sure that all required submittals have been included as part of your bid package.

• **COMPLETION OF BIDS**

The Bid Summary Sheets upon which the Bidder submits its prices shall be completed in ink or typewritten. The Bidder Acknowledgement Section should be completed in full and fully executed by an authorized representative of the Bidder. SBBC reserves the right to reject any bid which is not completed in full.

• **PRICING CORRECTIONS**

If a price correction is necessary on the Bid Summary Sheet, draw a single line through the entered figure and enter the corrected figure or use an opaque correction fluid. **All price corrections shall be initialed by the person signing the bid even when using opaque correction fluid.** SBBC reserves the right to not tabulate any illegible entries, pencil bids or price corrections not initialed and to reject any bid containing any of these errors.

• **DUE DATE**

Bids are due in Procurement and Warehousing Services on the date and time stated on Page 1 of the ITB. In order to have your bid considered, it must be received on or before the date and time due. Bids received after 2:00 p.m. ET on date due will not be considered.

• **STATEMENT OF "NO BID"**

If you are **not** submitting a bid in response to this ITB, please complete Section 8, Statement of "No Bid" and return via facsimile to 754-321-0533 or scan and send via e-mail to Bernadette.Green@browardschools.com. Your response to the Statement of "No" Bid is very important to Procurement and Warehousing Services when creating future ITBs.

Thank you for your interest in SBBC. Again, if you have any questions, please contact me at the telephone number or email address stated above.

Bernadette N. Green
Purchasing Agent

TABLE OF CONTENTS

<u>SECTION</u>	<u>Page</u>
1 Bidder Acknowledgement.....	1
2 Submittal Requirements	1
3 General Conditions.....	2
4 Special Conditions.....	8
5 Bid Summary Sheets.....	13
6 Bid Illustrations	133
7 FORMS AND ATTACHMENTS	
➤ Certification Regarding Debarment, Suspension, Ineligibility and Voluntary Exclusion - Lower Tier Covered Transactions.....	144
➤ Disclosure of Potential Conflict of Interest and Conflicting Employment or Contractual Relationship	146
➤ Drug-Free Workplace	147
➤ Insurance Requirements.....	148
➤ Legal Opinion on Bidder’s Preference.....	149
➤ W – 9 Form.....	150
➤ ACH Payment Agreement.....	154
8 Statement of “No Bid”	155
EXHIBIT A – M/WBE Participation Form and Monthly Utilization Report.....	156



The School Board of Broward County, Florida
PROCUREMENT AND WAREHOUSING SERVICES
 7720 West Oakland Park Boulevard, Suite 323
 Sunrise, Florida 33351-6704
 754-321-0505

INVITATION TO BID (ITB)

DUE DATE: Bids due at 2:00 p.m. Eastern Time (ET): July 21, 2015	ITB NO.: 16-033B	RELEASE DATE : June 17, 2015	PURCHASING AGENT: Bernadette N. Green 754-321-0524
Bids must be submitted to Procurement and Warehousing Services and received on or before 2:00 p.m. ET on the date due. Bids may not be withdrawn for 90 days after due date. Faxed bids are not allowed and will not be considered. Only the names of Bidders will be read at bid opening. Bid prices <u>will not</u> be read at bid opening (Florida Statute 119.071 2.)		BID TITLE: CAFETERIA EQUIPMENT	

SECTION 1, Bidder Acknowledgement

IN ACCORDANCE WITH GENERAL CONDITION 1, THIS SECTION MUST BE COMPLETED IN ITS ENTIRETY INCLUDING THE SIGNATURE OF AN AUTHORIZED REPRESENTATIVE WHERE INDICATED BELOW AND SUBMITTED WITH THE BID. FAILURE TO PROVIDE THIS DOCUMENT, WITH THE BID, WILL RESULT IN BID BEING CONSIDERED NON-RESPONSIVE.

Bidder's Name and state "Doing Business As", where applicable:	"REMIT TO" ADDRESS FOR PAYMENT: If payment(s) is/are to be mailed to address other than as stated on left, please complete section below. <input type="checkbox"/> Check this box if address is the same as stated on the left.
Address:	P.O. Address:
City:	
State: Zip Code:	City:
Telephone Number:	State: Zip Code:
Toll Free Number:	Contact:
Fax Number:	Telephone Number:
E-Mail Address of Authorized Representative:	Toll Free Number:
E-mail Address to Send Purchase Orders:	Fax Number:
Federal Tax Identification Number:	

I hereby certify that: I am submitting the following information as my firm's (Bidder) bid and am authorized by Bidder to do so. Bidder agrees to complete and unconditional acceptance of the contents of all pages in this Invitation To Bid (ITB), and all appendices and the contents of any Addenda released hereto; Bidder agrees to be bound to any and all specifications, terms and conditions contained in the ITB, and any released Addenda and understand that the following are requirements of this ITB and failure to comply will result in disqualification of bid submitted; Bidder has not divulged, discussed, or compared the bid with other Bidders and has not colluded with any other Bidder or party to any other bid; Bidder, its principals, or their lobbyists has not offered campaign contributions to School Board Members or offer contributions to School Board Members for campaigns of other candidates for political office during the period in which the Bidder is attempting to sell goods or services to the School Board. This period of limitation of offering campaign contributions shall commence at the time of the "cone of silence" period for any solicitation for a competitive procurement as described by School Board Policy 3320, Part II, Section GG as well as School Board Policy 1007, Section 5.4 – Campaign Contribution Fundraising. Bidder acknowledges that all information contained herein is part of the public record as defined by the State of Florida Sunshine and Public Records Laws; all responses, data and information contained in this bid are true and accurate.
 I agree that this bid cannot be withdrawn within 90 days from date due.

Signature of Authorized Representative (Manual)

Name of Authorized Representative (Typed or Printed)

Title

SECTION 2, Submittal Requirements

SUBMITTAL REQUIREMENTS: In order to assure that your bid is in compliance with bid requirements, please verify that the submittals indicated by the below have been submitted.

- | | | | |
|---|--|--|--|
| <input type="checkbox"/> Bid Bond
Special Condition __ | <input type="checkbox"/> Descriptive Literature
Special Condition __ | <input checked="" type="checkbox"/> M/WBE Participation
Exhibit A | <input type="checkbox"/> Material Safety Data Sheets
Special Condition __ |
| <input type="checkbox"/> Manufacturers Authorization
Special Condition __ | <input checked="" type="checkbox"/> Conflict of Interest Form
Section 7, Attachment 2 | <input type="checkbox"/> Bidder Questionnaire
Special Condition __ | <input checked="" type="checkbox"/> Bidder's Preference Statement
Special Condition 7 |
| <input checked="" type="checkbox"/> Certification Regarding Debarment,
Suspension, Ineligibility, and Voluntary Exclusion Form
Section 7, Attachment 1 | | | |

Note: If your firm wishes to not submit a bid in response to the ITB, please complete and return, via mail or fax, the Statement of No Bid attached as the last page of this ITB.

SECTION 3, GENERAL CONDITIONS

1. **SEALED BID REQUIREMENTS:** The "Bidder Acknowledgement Section" must be completed, signed and returned with the bid. The Bid Summary Sheet pages on which the Bidder actually submits a bid, and any pages, upon which information is required to be inserted, must be completed and submitted with the bid. **The School Board of Broward County (SBBC) reserves the right to reject any bid that fails to comply with these submittal requirements.**
 - a) **BIDDER'S RESPONSIBILITY:** It is the responsibility of the Bidder to be certain that all numbered pages of the bid and all attachments thereto are received and all Addendum released are received prior to submitting a bid without regard to how a copy of this ITB was obtained. All bids are subject to the conditions specified herein on the attached bid documents and on any Addenda issued thereto.
 - b) **BID SUBMITTED:** Completed bid must be submitted in a sealed envelope with bid number and name clearly typed or written on the front of the envelope. Bids must be time stamped in Procurement and Warehousing Services **on or before 2:00 p.m. ET on date due** for bid to be considered. Bids will be opened at 2:00 p.m. ET on date due. Bids submitted by telegraphic or facsimile transmission will not be accepted.
 - c) **EXECUTION OF BID:** Bid must contain an original manual signature of an authorized representative in the space provided above. All bids must be completed in ink or typewritten. **If a price correction is necessary, draw a single line through the entered figure and enter the corrected figure or use an opaque correction fluid. All price corrections must be initialed by the person signing the bid even when using opaque correction fluid. SBBC reserves the right to reject any bid or bid item completed in pencil or any bid that contains illegible entries or price corrections not initialed.**
 - d) **BIDDING PREFERENCE LAWS: ALL BIDDERS MUST COMPLETE AND SUBMIT THE LEGAL OPINION OF BIDDER'S PREFERENCE FORM IN ORDER TO BE CONSIDERED FOR AWARD.** The State of Florida provides a Bidder's preference for Florida vendors for the purchase of personal property. The local preference is five (5) percent. Bidders outside the State of Florida must have an Attorney, licensed to practice law in the out-of-state jurisdiction, as required by Florida Statute 287.084(2), execute the "Opinion of Out-of-State Bidder's Attorney on Bidding Preferences" form and must submit this form with the submitted bid. Such opinion should permit SBBC's reliance on such attorney's opinion for purposes of complying with Florida Statute 287.084. Florida Bidders must also complete its portion of the form. Failure to submit and execute this form, with the bid, shall result in bid being considered "non-responsive" and bid rejected.
2. **PRICES QUOTED:** Deduct trade discounts and quote firm net prices. Give both unit price and extended total. Prices must be stated in units to quantity specified in the bidding specification. In case of discrepancy in computing the amount of the bid, the **Unit Price** quoted will govern.

All prices quoted shall be F.O.B. destination and freight prepaid (Bidder pays and bears freight charges). Bidder owns goods in transit and files any claims unless otherwise stated in Special Conditions. Discounts for prompt payment: Award, if made, will be in accordance with terms and conditions stated herein. Each item must be bid separately and no attempt is to be made to tie any item or items in with any other item or items. **Cash or quantity discounts offered will not be a consideration in determination of award of bid(s).** If a Bidder offers a discount or offers terms less than Net 30, it is understood that a minimum of 30 days will be required for payment, and if a payment discount is offered, the discount time will be computed from the date of satisfactory delivery at place of acceptance and receipt of correct invoice at the office specified.

 - a) **TAXES:** The School Board of Broward County, Florida does not pay Federal Excise and State taxes on direct purchase of tangible personal property. The applicable tax exemption number is shown on the Purchase Order. This exemption does not apply to purchases of tangible personal property made by contractors who use the tangible personal property in the performance of contracts for the improvement of School Board owned real property as defined in Chapter 192 of the Florida Statutes.
 - b) **MISTAKES:** Bidders are expected to examine the specifications, delivery schedules, bid prices and extensions, and all instructions pertaining to supplies and services. Failure to do so will be at Bidder's risk.
 - c) **CONDITION AND PACKAGING:** It is understood and agreed that any item offered or shipped as a result of this bid shall be new (current production model at the time of this bid) unless otherwise specified. All containers shall be suitable for storage or shipment and all prices shall include standard commercial packaging.
 - d) **UNDERWRITERS' LABORATORIES:** Unless otherwise stipulated in the bid, all manufactured items and fabricated assemblies shall be UL listed where such has been established by UL for the item(s) offered and furnished. In lieu of the UL listing, Bidder may substitute a listing by an independent testing laboratory recognized by OSHA under the Nationally Recognized Testing Laboratories (NRTL) Recognition Program.
 - e) **BIDDER'S CONDITIONS:** Bid conditions and specifications **shall not** be changed, altered or conditioned in any way. The Board specifically reserves the right to reject any conditional bid.

3. **SAMPLES:** Samples of items, when required, must be furnished free of expense within five working days of request unless otherwise stated and, if not destroyed, will, upon request, be returned at the Bidder's expense. Bidders will be responsible for the removal of all samples furnished within 30 days after bid opening. All samples will be disposed of after 30 days. Each individual sample must be labeled with Bidder's name, bid number and item number. Failure of Bidder to either deliver required samples or to clearly identify samples as indicated may be reason for rejection of the bid. Unless otherwise indicated, samples should be delivered to Procurement and Warehousing Services, The School Board of Broward County, Florida, 7720 West Oakland, Park Boulevard, Suite 323, Sunrise, Florida 33351-6704.
4. **DELIVERY:** All deliveries shall be F.O.B. destination point. Unless actual date of delivery is specified (or if specified delivery cannot be met), show number of days required to make delivery after receipt of Purchase Order in space provided. Delivery time may become a basis for making an award (see Special Conditions). Delivery shall be within the normal working hours of the user, Monday through Friday, excluding state holidays and days during which the school district administration is closed.
5. **INTERPRETATIONS:** Any questions concerning conditions and specifications must be submitted in writing and received by Procurement and Warehousing Services no later than **ten working days, or as stated in the Special Conditions**, prior to the original bid opening date. If necessary, an Addendum will be issued.
6. **AWARDS:** In the best interest of SBBC, the Board reserves the right to: 1) withdraw this bid at any time prior to the time and date specified for the bid opening; 2) to reject any or all bids received when there are sound documented business reasons that serve the best interest of SBBC; 3) to accept any item or group of items unless qualified by Bidder; and 4) to acquire additional quantities at prices quoted on this ITB unless additional quantities are not acceptable, in which case, the bid sheets must be noted "BID IS FOR SPECIFIED QUANTITY ONLY." All awards made as a result of this bid shall conform to applicable Florida Statutes and shall be governed by the laws of the State of Florida, and must have venue established in the 17th Judicial Circuit Court of Broward County, Florida or the United States Court of the Southern District of Florida.
7. **BID OPENING:** Shall be public, on the date and at the time specified on the bid form. All bids received after that time shall not be considered.
8. **ADVERTISING:** In submitting a bid, Bidder agrees not to use the results there from as a part of any commercial advertising without prior approval of the School Board.
9. **INSPECTION, ACCEPTANCE & TITLE:** Inspection and acceptance will be at destination unless otherwise provided. Title to/risk of loss or damage to all items shall be the responsibility of the Awardee until acceptance by the buyer unless loss or damage resulting from negligence by the buyer. If the materials or services supplied to the Board are found to be defective or not conform to specifications, the Board reserves the right to cancel the order upon written notice to the seller and return product at Awardee's expense.
10. **PAYMENT:** Payment will be made by SBBC after the items awarded have been received, inspected, found to comply with award specifications and free of damage or defect and properly invoiced. All payments will be made by ACH (Automated Clearing House) for automatic deposits (credits).
11. **CONFLICT OF INTEREST AND CONFLICTING EMPLOYMENT OR CONTRACTUAL RELATIONSHIP:** Section 112.313 (3) and (7), Florida Statutes, sets forth restrictions on the ability of SBBC employees acting in a private capacity to rent, lease, or sell any realty, goods or services to SBBC. It also places restrictions on SBBC employees concerning outside employment or contractual relationships with any business entity which is doing business with SBBC. Each Bidder is to disclose any employees it has who are also SBBC employees by submitting Attachment 1, Disclosure of Potential Conflict of Interest and Conflicting Employment or Contractual Relationship, with its Bid. Any employees identified by the Bidder when completing Attachment 1 should obtain legal advice as to their obligations and restrictions under Section 112.313 (3) and (7), Florida Statutes.
12. **INSURANCE:** Bidder, by virtue of submitting a bid, shall be in full compliance with paragraph 20: LIABILITY INSURANCE, LICENSES AND PERMITS of the General Conditions. Insurance Requirements are shown in FORMS AND ATTACHMENTS Section of this ITB. Bidder shall take special notice that SBBC shall be named as an additional insured under the General Liability policy including Products Liability.

The insurance policies shall be issued by companies qualified to do business in the State of Florida. The insurance companies must be rated at least A-VI by AM Best or Aa3 by Moody's Investor Service. All policies must remain in effect during the performance of the contract.

13. **DISPUTES:** In case of any doubt or difference of opinion as to the items to be furnished hereunder, the decision of the School Board shall be final and binding on both parties.
14. **LICENSES, CERTIFICATIONS AND REGISTRATIONS:** As of the Bid Opening Date, Bidder must have all Licenses, Certifications and Registrations required when performing the services as described herein, in order for Bid to be considered a responsive and responsible Bid. Licenses, Certifications and Registrations required for this Bid shall be as required by Chapter 489, Florida Statutes, as currently enacted or as amended from time to time; by the State Requirements for Educational Facilities (SREF), latest version; and by Broward County, Florida. Bidder must submit a copy of all its current Licenses, Certifications and Registrations required as described herein, either with its Bid or within five working days of notification.
- An Awardee who has any License, Certification or Registration either suspended, revoked or expired after the date of the Bid Opening, shall provide notice to the Director of Supply Management & Logistics within five working days of such suspension, revocation or expiration. However, such suspension, revocation or expiration after the date of the Bid Opening shall not relieve the Awardee of its responsibilities under a contract awarded under this bid.*
15. **PATENTS & ROYALTIES:** The Awardee, without exception, shall indemnify and save harmless The School Board of Broward County, Florida and its employees from liability of any nature or kind, including cost and expenses for any copyrighted, patented, or unpatented invention, process, or article manufactured or used in the performance of the contract, including its use by The School Board of Broward County, Florida. If the Awardee uses any design, device, or materials covered by letters, patent, or copyright, it is mutually understood and agreed without exception that the bid prices shall include all royalties or cost arising from the use of such design, device or materials in any way involved in the work.
16. **OSHA:** The Awardee warrants that the product supplied to The School Board of Broward County, Florida shall conform in all respects to the standards set forth in the Occupational Safety and Health Act of 1970, as amended, and the failure to comply with this condition will be considered as a breach of contract.
17. **SPECIAL CONDITIONS:** The Superintendent or Designee has the authority to issue Special Conditions and Specifications as required for individual bids. Any and all Special Conditions that may vary from these General Conditions shall have precedence.
18. **ANTI-DISCRIMINATION:** The School Board of Broward County, Florida, prohibits any policy or procedure which results in discrimination on the basis of age, color, disability, gender identity, gender expression, national origin, marital status, race, religion, sex or sexual orientation. Individuals who wish to file a discrimination and/or harassment complaint may call the Executive Director, Benefits & EEO Compliance at 754-321-2150 or Teletype Machine TTY 754-321-2158.
19. **QUALITY:** All materials used for the manufacture or construction of any supplies, materials or equipment covered by this bid shall be new unless otherwise specified. The items bid must be new, the latest model, of the best quality and highest grade workmanship.
20. **LIABILITY INSURANCE, LICENSES AND PERMITS:** Where Awardees are required to enter or go onto School Board property to deliver materials or perform work or services as a result of a bid award, the Awardee agrees to The Hold Harmless Agreement stated herein and will assume the full duty obligation and expense of obtaining all necessary licenses, permits and insurance. The Awardee shall be liable for any damages or loss to the School Board occasioned by negligence of the Awardee (or agent) or any person the Awardee has designated in the completion of the contract as a result of their bid.
21. **BID BONDS, PERFORMANCE BONDS AND CERTIFICATES OF INSURANCE:** Bid bonds, when required, shall be submitted with the bid in the amount specified in Special Conditions. Bid bonds will be returned to non-Awardees. After acceptance of bid, the School Board will notify the Awardee to submit a performance bond and certificate of insurance in the amount specified in Special Conditions. Upon receipt of the performance bond, the bid bond will be returned to the Awardee.
22. **CANCELLATION:** In the event any of the provisions of this bid are violated by the contractor, the Superintendent shall give written notice to the contractor stating the deficiencies and unless deficiencies are corrected within five days, recommendation will be made to the School Board for immediate cancellation.
23. **BILLING INSTRUCTIONS:** Invoices, unless otherwise indicated, must show Purchase Order numbers and shall be submitted in duplicate to The School Board of Broward County, Florida, Accounting and Financial Reporting Department, Attn: Accounts Payable, 600 S.E. 3rd Avenue, 7th Floor, Fort Lauderdale, Florida 33301. Payment will be made a minimum of 30 days after delivery, authorized inspection and acceptance. When vendors are directed to send invoices to a school, the school will make direct payments to the vendor.
24. **NOTE TO VENDORS DELIVERING TO MATERIALS LOGISTICS CENTRAL (WAREHOUSE):** Receiving hours are Monday through Friday (excluding state holidays and days during which the school district administration is closed) **7:00 a.m. to 2:00 p.m. ET.**
25. **SUBSTITUTIONS:** The School Board of Broward County, Florida **WILL NOT** accept substitute shipments of any kind. Awardees are expected to furnish the brand quoted in their bid once awarded by the School Board. Any substitute shipments will be returned at the Awardee's expense.
26. **FACILITIES:** SBBC reserves the right to inspect the Awardee's facilities at any time with prior notice. SBBC may use the information obtained from this in determining whether a Bidder is a responsible Bidder.
27. **BID ABSTRACTS:** Bid tabulations are available at www.demandstar.com.
28. **ASBESTOS AND FORMALDEHYDE STATEMENT:** All building materials, pressed boards, and furniture supplied to SBBC shall be **100% asbestos free. It is desirous that all building materials, pressed boards and furniture supplied to the School Board also be 100% formaldehyde free.** Bidder, by virtue of bidding, certifies by signing bid that, if awarded this bid, only building materials, pressed boards, and/or furniture that is **100% asbestos free** will be supplied.
29. **ASSIGNMENT:** Neither any award of this bid nor any interest in any award of this bid may be assigned, transferred or encumbered by any party without the prior written consent from the Director, Procurement and Warehousing Services. There shall be no partial assignments of this "Bid/RFP" including, without limitation, the partial assignment of any right to receive payments from SBBC.
30. **EXTENSION:** In addition to any extension options contained herein, SBBC is granted the right to extend any award resulting from this bid for the period of time necessary for SBBC to release, award and implement a replacement bid for the goods, products and/or services provided through this bid. Such extension shall be upon the same prices, terms and conditions as existing at the time of SBBC's exercise of this extension right. The period of any extension under this provision shall not be for a period in excess of six months from (a) the termination date of a contract entered into as a result of this bid or (b) the termination date under any applicable period of extension under a contract entered into as a result of this bid.
31. **OMISSION FROM THE SPECIFICATIONS:** The apparent silence of this specification and any Addendum regarding any details or the omission from the specification of a detailed description concerning any point shall be regarded as meaning that only the best available units shall be provided and the best commercial practices are to prevail, and that only materials and workmanship of first quality are to be used. All interpretations of this specification shall be made upon the basis of this agreement.
32. **SUBMITTAL OF INVOICES:** All Bidders are hereby notified that any invoice submitted as a result of the award of this bid must be in the same format as any Purchase Order released as a result of the award of this bid. **Each line of the invoice must reference a corresponding single line shown on the Purchase Order.** A single invoice line must not correspond to or commingle the cost shown on multiple Purchase Order lines. An invoice submitted that does not follow the same format and line numbering as shown on the Purchase Order will be deemed to be not correct, and may be returned to the vendor by the Accounts Payable Department for correction. Address for submitting invoices is included on Purchase Order.
33. **PURCHASE AGREEMENT:** This bid and the corresponding Purchase Orders will constitute the complete agreement. SBBC will not accept proposed terms and conditions that are different than those contained in this Invitation to Bid, including pre-printed text contained on catalogs, price lists, other descriptive information submitted or any other materials. By virtue of submitting a bid, vendor agrees to not submit to any SBBC employee, for signature, any document that contains terms and conditions that are different than those contained herein and that in the event any document containing any term or condition that differs from those contained herein is executed, said document shall not be binding on SBBC.
34. **SBBC INFORMATION SECURITY GUIDELINES:** It is the responsibility of the vendor to read and adhere to the SBBC Information Security Guidelines when using any device connected to the SBBC's network. Following the conclusion of the contract term, all of SBBC's confidential information must be removed from vendor's equipment and all access privileges must be revoked. Final payment will be withheld until the vendor has confirmed, in writing, that all SBBC's confidential information has been purged from any and all electronic technology devices that were used during this contract and were connected to the SBBC's network.

35. **PROTESTING OF BID CONDITIONS/SPECIFICATIONS:** Any person desiring to protest the conditions/specifications in this ITB, or any Addenda subsequently released thereto, shall file a notice of intent to protest, in writing, within 72 hours after electronic release of the competitive solicitation or Addendum and shall file a formal written protest within ten calendar days after the date the notice of protest was filed. Saturdays, Sundays, state holidays or days during which the school district administration is closed shall be excluded in the computation of the 72 hours. If the tenth calendar day falls on a Saturday, Sunday, state holiday or day during which the school district administration is closed, the formal written protest must be received on or before 5:00 p.m. ET of the next calendar day that is not a Saturday, Sunday, state holiday or day during which the school district administration is closed. Section 120.57(3)(b), Florida Statutes, as currently enacted or as amended from time to time, states that **"The formal written protest shall state with particularity the facts and law upon which the protest is based."**
- Failure to file a notice of protest or to file a formal written protest within the time prescribed by Section 120.57(3), Florida Statutes, or a failure to post the bond or other security required by SBBC Policy 3320, within the time allowed for filing a bond, shall constitute a waiver of proceedings. The failure to post the bond required by SBBC Policy 3320, Part VIII, as currently enacted or as amended from time to time, shall constitute a waiver of proceedings. Notices of protest, formal written protests, and the bonds required by SBBC Policy 3320, shall be filed at the office of the Director, Procurement and Warehousing Services, 7720 West Oakland Park Boulevard, Suite 323, Sunrise, Florida 33351-6704 (fax 754-321-0936). Fax filing will not be acceptable for the filing of bonds.
36. **POSTING OF BID RECOMMENDATIONS/TABULATIONS:** ITB Recommendations and Tabulations will be posted in Procurement and Warehousing Services and on www.demandstar.com on July 30, 2015 at 3:00 p.m. ET, and will remain posted for 72 hours. Any change to the date and time established herein for posting of ITB Recommendations/Tabulations shall be posted in Procurement and Warehousing Services and/or at www.demandstar.com (under the document section for this ITB). In the event the date and time of the posting of ITB Recommendations/Tabulations is changed, it is the responsibility of each Bidder to ascertain the revised date of the posting of ITB Recommendations/Tabulations. Any person desiring to protest the intended decision shall file a notice of protest, in writing, within 72 hours after the posting of the ITB tabulation and shall file a formal written protest within ten calendar days after the date the notice of protest was filed. Saturdays, Sundays, state holidays and days during which the school district administration is closed shall be excluded in the computation of the 72 hours. If the tenth calendar day falls on a Saturday, Sunday, state holiday or day during which the school district administration is closed, the formal written protest must be received on or before 5:00 p.m. ET of the next calendar day that is not a Saturday or Sunday, state holiday or days during which the school district administration is closed. No submissions made after the Bid opening amending or supplementing the Bid shall be considered. Section 120.57(3)(b), Florida Statutes, as currently enacted or as amended from time to time, states that **"The formal written protest shall state with particularity the facts and law upon which the protest is based"**. Any person who files an action protesting an intended decision shall post with SBBC, **at the time of filing the formal written protest**, a bond, payable to SBBC, in an amount equal to one percent (1%) of SBBC's estimate of the total volume of the contract. SBBC shall provide the estimated contract amount to the vendor within 72 hours, excluding Saturdays, Sundays and other days during which SBBC administration is closed, of receipt of notice of intent to protest. The estimated contract amount is not subject to protest pursuant to Section 120.57(3), Florida Statutes. The bond shall be conditioned upon the payment of all costs which may be adjudged against the protestant in an Administrative Hearing in which the action is brought and in any subsequent appellate court proceeding. In lieu of a bond, SBBC may accept a cashier's check, official bank check or money order in the amount of the bond. If, after completion of the Administrative Hearing process and any appellate court proceedings, SBBC prevails, SBBC shall recover all costs and charges which shall be included in the Final Order or judgment, including charges made by the Division of Administrative Hearings, but excluding attorney's fees. Upon payment of such costs and charges by the protestant, the bond shall be returned. If the protestant prevails, then the protestant shall recover from the School Board all costs and charges which shall be included in the Final Order or judgment, excluding attorney's fees. **All documentation necessary for the protest proceedings will be provided electronically by SBBC.**
36. (Continued):
- Failure to file a notice of protest or to file a formal written protest within the time prescribed by Section 120.57(3), Florida Statutes, or a failure to post the bond or other security required by SBBC Policy 3320 within the time allowed for filing a bond, shall constitute a waiver of proceedings. The failure to post the bond required by SBBC Policy 3320, Part VIII, as currently enacted or as amended from time to time, shall constitute a waiver of proceedings. Notices of protests, formal written protests, and the bonds required by Policy 3320, shall be filed at the office of the Director, Procurement and Warehousing Services, 7720 West Oakland Park Boulevard, Suite 323, Sunrise, Florida 33351-6704 (fax 754-321-0936). Fax filing will not be acceptable for the filing of bonds.**
37. **SUBMITTAL OF BIDS:** All Bidders are reminded that it is the sole responsibility of the BIDDER to assure that their bid is time stamped in PROCUREMENT AND WAREHOUSING SERVICES on or before 2:00 p.m. ET on date due. The address for bid submittal, including hand delivery and overnight courier delivery, is indicated as: 7720 West Oakland Park Boulevard, Suite 323, Sunrise, Florida 33351-6704. The Bidder is fully and completely responsible for the payment of all delivery costs associated with the delivery of their bid or related material. Procurement and Warehousing Services will not accept delivery of any bid or related material requiring the School Board to pay for any portion of the delivery cost or the complete delivery cost. Prior to bid submittal, it is the responsibility of the Bidder to be certain that all Addenda released have been received, that all Addendum requirements have been completed, and that all submittals required by the Addendum have been timely filed. (See General Condition 1.)
38. **PACKING SLIPS:** It will be the responsibility of the Awardee to attach all packing slips to the OUTSIDE of each shipment. Packing slip must reference SBBC Purchase Order number/control number. Failure to provide packing slip attached to the outside of shipment will result in refusal of shipment at vendor's expense.
39. **USE OF OTHER CONTRACTS:** SBBC reserves the right to utilize any other SBBC contract, any State of Florida Contract, any contract awarded by any other city or county governmental agencies, other school boards, other community college/state university system cooperative bid agreement, or to directly negotiate/purchase per School Board policy and/or State Board Rule 6A-1.012, as currently enacted or as amended from time to time, in lieu of any offer received or award made as a result of this bid if it is in its best interest to do so.
40. **INDEMNIFICATION: This General Condition of the bid is NOT subject to negotiation and any bid that fails to accept these conditions will be rejected as "non-responsive."**
- a) SBBC agrees to be fully responsible for its acts of negligence or its agents' acts of negligence when acting within the scope of their employment and agrees to be liable for any damages resulting from said negligence. Nothing herein is intended to serve as a waiver of sovereign immunity by SBBC. Nothing herein shall be construed as consent by SBBC to be sued by third parties in any matter arising out of any contract. Nothing herein shall be construed as a waiver by SBBC of any rights or limits to liability under Section 768.28, Florida Statutes.
- b) VENDOR agrees to indemnify, hold harmless and defend SBBC, its agents, servants and employees from any and all claims, judgments, costs and expenses including, but not limited to, reasonable attorney's fees, reasonable investigative and discovery costs, court costs and all other sums which SBBC, its agents, servants and employees may pay or become obligated to pay on account of any, all and every claim or demand, or assertion of liability, or any claim or action founded thereon, arising or alleged to have arisen out of the products, goods or services furnished by the VENDOR, its agents, servants or employees; the equipment of the VENDOR, its agents, servants or employees while such equipment is on premises owned or controlled by SBBC; or the negligence of VENDOR or the negligence of VENDOR's agents when acting within the scope of their employment, whether such claims, judgments, costs and expenses be for damages, damage to property including SBBC's property, and injury or death of any person whether employed by the VENDOR, SBBC or otherwise.
41. **PURCHASE BY OTHER PUBLIC AGENCIES:** With the consent and agreement of the awarded contractor(s), purchases may be made under this bid by other agencies. Such purchases shall be governed by the same terms and conditions as stated herein.

42. **PUBLIC ENTITY CRIMES:** Section 287.133(2)(a), Florida Statutes, as currently enacted or as amended from time to time, states that a person or affiliate who has been placed on the convicted vendor list following a conviction for a public entity crime may not submit a bid on a contract to provide any goods or services to a public entity, may not submit a bid on a contract with a public entity for the construction or repair of a public building or public work, may not submit bids on leases of real property to a public entity, may not be awarded or perform work as a contractor, supplier, subcontractor, or consultant under a contract with any public entity, and may not transact business with any public entity in excess of the threshold amount provided in Section 287.017 for CATEGORY TWO [currently \$25,000] for a period of 36 months from the date of being placed on the convicted vendor list.
43. **CERTIFICATION REGARDING DEBARMENT, SUSPENSION, INELIGIBILITY OR VOLUNTARY EXCLUSION - Lower Tier Covered Transactions:** Executive Order 12549, as currently enacted or as amended from time to time, provides that, to the extent permitted by law, Executive departments and agencies shall participate in a government-wide system for non-procurement debarment and suspension. A person who is debarred or suspended shall be excluded from Federal financial and non-financial assistance and benefits under Federal programs and activities. Except as provided in § 85.200, Debarment or Suspension, § 85.201, Treatment of Title IV HEA participation, and § 85.215, Exception Provision, debarment or suspension of a participant in a program by one agency shall have government-wide effect. A lower tier covered transaction is, in part, any transaction between a participant [SBBC] and a person other than a procurement contract for goods or services, regardless of type, under a primary covered transaction; and any procurement contract for goods or services between a participant and a person, regardless of type, expected to equal or exceed the Federal procurement small purchase threshold fixed at 10 U.S.C. 2304(g) and 41 U.S.C. 253(g) (currently \$100,000) under a primary covered transaction; or any procurement contract for goods or services between a participant and a person under a covered transaction, regardless of amount, under which that person will have a critical influence on or substantive control over that covered transaction. A participant may rely upon the certification of a prospective participant in a lower tier covered transaction that it and its principals are not debarred, suspended, proposed for debarment under 48 CFR part 9, subpart 9.4, ineligible, or voluntarily excluded from the covered transaction, unless it knows that the certification is erroneous. Each participant shall require participants in lower tier covered transactions to include the certification for it and its principals in any bid submitted in connection with such lower tier covered transactions.
- CERTIFICATION**
- a) The prospective lower tier participant certifies, by submission of this bid, that neither it nor its principals is presently debarred, suspended, proposed for debarment, declared ineligible, or voluntarily excluded from participation in this transaction by any Federal department or agency.
- b) Where the prospective lower tier participant is unable to certify to any of the statements in this certification, such prospective participant shall attach an explanation to this bid.
44. **REASONABLE ACCOMMODATION:** Individuals with disabilities requesting accommodations under the Americans with Disabilities Act (ADA) may call Equal Educational Opportunities (EEO) at 754-321-2150 or Teletype Machine TTY 754- 321-2158.
45. **SEVERABILITY:** In case of any one or more of the provisions contained in this Bid shall be for any reason be held to be invalid, illegal, unlawful, unenforceable or void in any respect, the invalidity, illegality, unenforceability or unlawful or void nature of that provision shall not affect any other provision and this Bid shall be considered as if such invalid, unlawful, unenforceable or void provision had never been included herein.
46. **DISTRIBUTION:** DemandStar by Onvia, www.demandstar.com, is the official method approved by Procurement and Warehousing Services for the distribution of all competitive solicitations including ITBs and RFPs. It is the responsibility of all interested parties to assure they have received all necessary documents, including Addenda and have included all necessary information within their response. SBBC is not responsible for Bidder's failure to obtain complete bidding documents from DemandStar. SBBC reserves the right to reject any bid as non-responsive for failure to include all necessary documents or required Addenda. For information regarding the above referenced solicitation, contact the designated Purchasing Agent as stated herein.
47. **LOBBYIST ACTIVITIES:** In accordance with SBBC Policy 1100B, as currently enacted or as amended from time to time, persons acting as lobbyists must state, at the beginning of their presentation, letter, telephone call, e-mail or facsimile transmission to School Board Members, Superintendent or Members of Senior Management, the group, association, organization or business interest she/he is representing.
- a) A lobbyist is defined as a person who for immediate or subsequent compensation, (e.g., monetary profit/personal gain) represents a public or private group, association, organization or business interest and engages in efforts to influence School Board Members on matters within their official jurisdiction.
- b) A lobbyist is not considered a person representing school-affiliated groups (e.g., PTA, DAC, Band Booster Associations, etc.) nor a public official acting in her/his official capacity.
- c) Lobbyists shall annually (July 1) disclose in each instance and for each client prior to any lobbying activities, their identity and activities by completing the lobbyist statement form which can be obtained from Official School Board Records, School Board Member's Offices or the Superintendent's Office and will be recorded on The School Board of Broward County's website, www.browardschools.com.
- d) The lobbyist must disclose any direct business association with any current elected or appointed official or employee of SBBC or any immediate family member of such elected or appointed official or employee of SBBC.
- e) Senior-level employees (Pay Grade 30 and above) and/or School Board Members are prohibited from lobbying activities for one year after resignation or retirement or expiration of their term of office.
- f) The Executive Director, Public Relations & Governmental Affairs shall keep a current list of persons who have submitted the lobbyist statement form.
48. **TIE BID PROCEDURES:** When identical prices are received from two or more vendors and all other factors are equal, priority for award shall be given to vendors in the following sequence:
- A business that certifies that it has implemented a drug-free workplace program shall be given preference in accordance with the provisions of Chapter 287.087, Florida Statutes, as currently enacted or as amended from time to time;
 - The Broward County Certified Minority/Women Business Enterprise vendor;
 - The Palm Beach County or Miami-Dade County Certified Minority/Women Business Enterprise vendor;
 - The Florida Certified Minority/Women Business Enterprise vendor;
 - The Broward County vendor, other than a Minority/Women Business Enterprise vendor;
 - The Palm Beach County or Miami-Dade County vendor, other than a Minority/Women Business Enterprise vendor;
 - The Florida vendor, whose main office is in the State of Florida, other than a Minority/Women Business Enterprise vendor.
 - If application of the above criteria does not indicate a priority for award, the award will be decided by a coin toss. The coin toss shall be held publicly in Procurement and Warehousing Services; the tie low bid vendors invited to be present as witnesses.
- Included as a part of these bid documents is a Form entitled **SWORN STATEMENT PURSUANT TO CHAPTER 287.087, FLORIDA STATUTES, AS CURRENTLY ENACTED OR AS AMENDED FROM TIME TO TIME, ON PREFERENCE TO BUSINESSES WITH DRUG-FREE WORKPLACE PROGRAMS.** This form will be used by the Bidder to certify that it has implemented a drug-free workplace program. In order for bid to be considered, the Invitation to Bid form (Page 1 of this bid) must be properly signed in order for the bid to be considered. A Bidder cannot sign this form in lieu of properly signing the Invitation to Bid form.

49. **MINORITY/WOMEN BUSINESS ENTERPRISE (M/WBE) PARTICIPATION:** SBBC has a Minority/Women Business Enterprise (M/WBE) Program. M/WBE is defined by SBBC as any legal entity, other than a joint venture, which is organized to engage in commercial transactions and which is at least 51% owned and controlled by minority or women persons. If the Bidder is a Certified M/WBE by SBBC, Bidder should indicate its certification number on the Bid Summary Sheet. **M/WBE participation is strongly encouraged.** For information on M/WBE Certification, contact the School Board's Supplier Diversity & Outreach Program at 754-321-0550 or www.broward.k12.fl.us/supply/vendor/mwbe.htm.
50. **SBBC MATERIAL NUMBER:** The seven digit number shown in parenthesis at the beginning of an item on the Bid Summary Sheet represents the School Board's material number for the item. It does not represent any manufacturer/distributor model/part number.
51. **SBBC PHOTO IDENTIFICATION BADGE:**
Background Screening: Awardee agrees to comply with all the requirements of Sections 1012.32 and 1012.465, Florida Statutes, and that Awardee and all its personnel who (1) are to be permitted access to school grounds when students are present, (2) will have direct contact with students, or (3) have access or control of school funds will successfully complete the background screening required by the referenced statutes and meet the standards established by the statutes. **Personnel shall include employees, representatives, agents or sub-contractors performing duties under the contract to SBBC, and who meet any or all of the three requirements identified above.** This background screening will be conducted by SBBC in advance of Awardee or its personnel providing any services. Awardee will bear the cost of acquiring the background screening required under Section 1012.32, Florida Statutes, and any fee imposed by the Florida Department of Law Enforcement to maintain the fingerprints provided with respect to Awardee and its personnel. The Parties agree that the failure of Awardee to perform any of the duties described in this section shall constitute a material breach of this ITB entitling SBBC to terminate immediately with no further responsibilities or duties to perform under this Agreement. Awardee agrees to indemnify and hold harmless SBBC, its officers and employees of any liability in the form of physical or mental injury, death or property damage resulting in Awardee's failure to comply with the requirements of this section or Sections 1012.32 and 1012.465, Florida Statutes.
- SBBC issued identification badges must be worn at all times when on SBBC property and must be worn where they are visible and easily readable.**
- MorphoTrust USA, LLC has been contracted to provide all background and fingerprinting services. All questions pertaining to fingerprinting, photo identification and background check services must be directed to the EasyPath Project Coordinator at 754-321-1830 or EasyPathInfo@morphotrust.com. **Each individual, for whom a SBBC photo identification badge is requested, must fill out the forms that are required, provide his/her driver's license and social security card, and must be fingerprinted.** A background check will be conducted for each badge applicant. SBBC reserves the right to require additional information, should it be necessary, and to deny the issuance of a badge to an applicant. Any applicant, that has been denied a badge, is prohibited from entering SBBC property as an employee, sub-contractor or agent of a contract Awardee. There will be two websites used for services: 1) <http://www.1enrollment.com/state/?st=broward> (used for scheduling and registering applicants) 2) <https://sbcc-easypath.browardschools.com/EasyPathWeb/Web.dll> (used for vendors to check the status of applicants and order replacement badges) and 3) <http://www.1enrollment.com/state/forms/broward/51f2c822ca09f.pdf> (form/application). The total fee for the SBBC photo identification badge, fingerprinting and a FBI background check can be found at the following website: <http://www.identogo.com>. Payment options can be made by electronic check (e-check), Visa, MasterCard or use of an established escrow account code. **These fees are non-refundable and are subject to change without notice. Badges are issued for a one-year period and must be renewed annually. The renewal date will be one year from date of issuance. Failure to renew the badge, at that time, will result in the vendor being required to re-apply and pay the going rate for badging and fingerprinting.**
- Vendors shall return expired and/or terminated employee badges to the following location: The School Board of Broward County, Florida, Attn: MorphoTrust USA, LLC, 600 S.E. 3rd Avenue, Fort Lauderdale, Florida 33301.**
52. **AUDIT AND INSPECTION OF AWARDEE'S DOCUMENTS AND RECORDS:** The District or its representative reserves the right to inspect and/or audit all the Awardee's documents and records as they pertain to the products and services delivered under this agreement. Such rights will be exercised with notice to the Awardee to determine compliance with and performance of the terms, conditions and specifications on all matters, rights and duties, and obligations established by this agreement. Documents/records in any form shall be open to the District or State's representative and may include but are not limited to all correspondence, ordering, payment, inspection, and receiving records, contracts or sub-contracts that directly or indirectly pertain to the transactions between the District and the Awardee(s).
53. **ORIGINAL DOCUMENT FORMAT:** Only the terms and conditions of this solicitation as they were released by SBBC, or amended via Addendum, are valid. Any modification to any term or condition by a vendor is not binding unless it is expressly agreed to, in writing, by SBBC.
54. **CREDIT CARDS:** Individual schools and departments may place some orders and utilize, as the form of payment, a District-issued credit card to the extent authorized by the School Board. These orders will be made via phone or fax for direct delivery and billing to the requesting work location. Please note that credit card purchases will benefit all vendors by providing immediate payment (i.e. within 48-72 hours), thereby eliminating the need to submit an invoice to the District's Accounts Payable Department or reconcile receivable balances. For credit card purchases, all vendors must have the capability to accept fax orders, which must be confirmed by calling back the requesting work location to verify prices and obtain a credit card number. Only actual items shipped/delivered can be charged to the credit card account (i.e., no back-orders). All purchase deliveries must include a packing slip or receipt/invoice listing the items and prices of goods delivered. For security reasons, the credit card charge receipt showing the work location's credit card number cannot be attached to the packing slip or receipt/invoice submitted as part of the purchase delivery. District work locations may request that a vendor maintains secure records of the credit card account assigned an alias or password, to avoid divulging the actual credit card number upon every purchase.
55. **NONCONFORMANCE TO CONTRACT CONDITIONS:** Items offered may be tested for compliance with bid conditions and specifications at any time. Items delivered, not conforming to bid conditions or specifications, may be rejected and returned at vendor's expense. Goods or services not delivered as per delivery date in bid and/or Purchase Order may be rejected upon delivery and/or may be purchased on the open market. Any increase in cost may be charged against the Awardee. Any violation of these stipulations may also result in:
 a) For a period of two years, any bid submitted by vendor will not be considered and will not be recommended for award.
 b) All departments being advised not to do business with vendor.
56. **CONE OF SILENCE:** Any proposer, or lobbyist for a proposer, is prohibited from having any communications (except as provided in this rule) concerning any solicitation for a competitive procurement with any School Board member, the Superintendent, any Evaluation Committee Member, or any other School District employee after Procurement and Warehousing Services releases a solicitation to the General Public. All communications regarding this solicitation shall be directed to the designated Purchasing Agent unless so notified by Procurement and Warehousing Services. This "Cone of Silence" period shall go into effect and shall remain in effect from the time of release of the solicitation until the contract is awarded by the School Board. Further, any vendor, its principals, or their lobbyists shall not offer campaign contributions to School Board Members or offer contributions to School Board Members for campaigns of other candidates for political office during the period in which the vendor is attempting to sell goods or services to the School Board. This period of limitation of offering campaign contributions shall commence at the time of the "cone of silence" period for any solicitation for a competitive procurement as described by School Board Policy 3320, Part II, Section GG as well as School Board Policy 1007, Section 5.4 – Campaign Contribution Fundraising. **Any vendor or lobbyist who violates this provision shall cause their Proposal (or that of their principal) to be considered non-responsive and therefore be ineligible for award.**
57. **TERMINATION:** This contract award may be terminated with or without cause by SBBC during the term hereof thirty (30) days after the Superintendent gives written notice to the other parties that a recommendation will be made to the School Board for the contract award's termination.
58. **EVALUATION AND BIDS:** SBBC evaluates all Bids in accordance with the State of Florida Statutes 119.071 and 286.0113.

59. **MEET OR RELEASE:** If during the contract term, SBBC is offered a lower price from a third party supplier for a product or service awarded under this contract, or offers another item that meets or exceeds the specifications for the item at a lower price than the awarded price, SBBC will request Awardee to meet the lower price offered by the third party supplier. Awardee will be required to respond to this request within three (3) days of request. If Awardee is unable to meet the lower price, SBBC will be released from its contractual obligation to purchase the item under this contract. No response to this request will indicate that Awardee is unable to offer item at a lower price. This action, purchasing awarded item from third party supplier, will not hold SBBC in default of contract. Each purchase will be considered separate and apart from each other.

60. **CONFIDENTIAL RECORDS:** The Awardee acknowledges that certain information about the District's students is contained in records created, maintained or accessed by the Vendor and that this information is confidential and protected by the Family Educational Rights and Privacy Act of 1974 (FERPA) (20 U.S.C. 1232g), and/or the Health Insurance Portability and Accountability Act (HIPAA) (45 CFR parts 160-164) and related District policies, as amended from time to time, currently available at www.browardschools.com. The confidential information cannot be disclosed unless valid consent is obtained from the students or their legal guardians. Both parties agree to protect these records in compliance with FERPA, HIPAA, and the District's policy. To the extent permitted by law, nothing contained herein shall be construed as precluding either party from releasing such information to the other so that each can perform its respective responsibilities.

Vendor agrees that it may create, receive from or on behalf of the District, or have access to, records or record systems that are subject to FERPA and/or HIPAA (collectively, the "Confidential Records"). Vendor represents, warrants, and agrees that it will: (1) hold the Confidential Records in strict confidence and will not use or disclose the Confidential Records except as (a) permitted or required by this Agreement, (b) required by law, or (c) otherwise authorized by the District in writing; (2) safeguard the Confidential Records according to commercially reasonable administrative, physical and technical standards as required by law; and (3) continually monitor its operations and take any and all action necessary to assure that the Confidential Records are safeguarded in accordance with the terms of this Agreement. At the request of the District, Vendor agrees to provide the District with a written summary of the procedures Vendor uses to safeguard the Confidential Records. A breach of these confidentiality requirements shall constitute grounds for the District to terminate any Agreement with Vendor.

SECTION 4, SPECIAL CONDITIONS

INTRODUCTION AND SCOPE:

1. The School Board of Broward County, Florida (hereinafter referred to as "SBBC") desires bids on **CAFETERIA EQUIPMENT** as specified herein. The scope of requirements includes, but is not limited to, cafeteria equipment. Unit price quoted shall include **inside** delivery and placement of equipment, leveling of equipment, removal of cartons, all shipping and handling costs, F.O.B. destination, service manuals, parts list, schematics installation plug-in, assembly and demonstration costs to various schools with Broward County. Awardee(s) will receive individual purchase orders specifying the school's name and "ship-to" address.. **One hard-copy bid and one identical electronic version of the bid, in Microsoft Word 6.0 or higher on CD/diskette/flash drive, must be submitted in time for bid opening.**

2. **TERM:** The award of this bid shall establish a contract for the period **beginning from date of award and continuing through December 31, 2017**. Bids will not be considered for a shorter period of time. Items will be ordered on an as-needed basis. . If only one bid is received, the term of the contract will be reduced to one year.

3. **AWARD:** In order to meet the needs of SBBC, each **ITEM OR GROUP**, as indicated on the Bid Summary Sheet, shall be awarded up to the two lowest responsive and responsible Bidders meeting specifications, terms and conditions. The lowest Awardee for an item or group shall be considered the primary vendor and should receive the largest volume of work. Therefore, it is necessary to bid on every item in the group, and all items in the group must meet specifications in order to have the bid considered for award. Unit prices must be stated in the space provided on the Bid Summary Sheet. SBBC reserves the right to procure goods from the second lowest Bidders if: a) the lowest Awardee cannot comply with delivery requirements or specifications; b) the lowest Awardee is not in compliance with delivery requirements or specifications on current or previous orders; c) in cases of emergency; d) or if it is in the best interest of SBBC. When a bid has both a primary and alternate Awardee, and the primary Awardee is unable to perform during the term of the contract, Procurement and Warehousing Services will negotiate with the alternate Awardee for the same or lower unit prices as those submitted by the primary Awardee.

After award of this bid, any Awardee who violates any specification, term or condition of this bid can be found in default of its contract, have its contract canceled, be subject to the payment of liquidated damages, and be removed from the bid list and not be eligible to do business with SBBC for two years, as described in General Conditions 22 and 55.

4. **INFORMATION:** Any questions by prospective Bidders concerning this Invitation to Bid should be addressed to **Bernadette Green, Purchasing Agent, Procurement and Warehousing Services, 754-321-0524 or e-mail at Bernadette.Green@browardschools.com** who is authorized only to direct the attention of prospective Bidders to various portions of the bid so they may read and interpret such for themselves. Neither **Ms. Green**, nor any employee of SBBC, is authorized to interpret any portion of the bid or give information as to the requirements of the bid in addition to that contained in the written bid document. **Questions should be submitted in accordance with General Condition 5**. Interpretations of the bid or additional information as to its requirements, where necessary, shall be communicated to Bidders only by written Addendum. Any verbal or written information, which is obtained other than by information in this ITB document or by Addenda, shall not be binding on SBBC.

5. **CONTRACT RENEWAL:** The purpose of this bid is to establish a contract, at firm unit prices, for the purchase of estimated requirements for the items listed. The term of the bid shall be for three (3) year(s), and may, by mutual agreement between SBBC and the Awardee, be renewed for two additional one-year periods and, if needed, 90 days beyond the expiration date of the final renewal period. Procurement and Warehousing Services, will, if considering renewing, request a letter of intent to renew from each Awardee, prior to the end of the current contract period. The Awardee will be notified when the recommendation has been acted upon by the School Board. All prices shall be firm through the period stated in Special Condition 18 - Price Adjustments for the term of the contract. The Bidder(s) agrees to this condition by signing its bid

VENDOR NAME: _____

BNG

The School Board of Broward County, Florida
CAFETERIA EQUIPMENT

SECTION 4, SPECIAL CONDITIONS (Continued)

6. **DELIVERY:** Bidder shall indicate delivery information on Bid Summary Sheets where indicated. Delivery is desired no later than **45 days after receipt of order (ARO)**. Offers, which exceed this period, may be rejected if it is in the best interest of SBBC.
7. **BIDDING PREFERENCE LAWS: ALL BIDDERS MUST COMPLETE AND SUBMIT SECTION 7, ATTACHMENT 5 TO BE CONSIDERED FOR AWARD.** The State of Florida provides a Bidder's preference for Bidders whose principal place of business is within the State of Florida for the purchase of personal property. The local preference is five (5) percent. Bidders whose principal place of business is outside the State of Florida must have an Attorney, licensed to practice law in the out-of-state jurisdiction, as required by Florida Statute 287.084(2), execute the "Opinion of Out-of-State Bidder's Attorney on Bidding Preferences" form, Section 7, Attachment 5, and must submit this form with submitted bid. Such opinion should permit SBBC's reliance on such attorney's opinion for purposes of complying with Florida Statute 287.084. Florida Bidders are not required to have an Attorney render an opinion but the Florida Bidder must complete its portion of this form. Failure to submit and execute this form, with bid, shall result in bid being considered "non-responsive" and bid rejected.
8. **QUANTITIES:** The quantities listed on the Bid Summary Sheet are estimated quantities to be ordered throughout the contract period for each item and are not a guarantee. Actual quantities ordered throughout the contract period may be greater or less than the bid estimates and shall be furnished at the fixed contract price. Purchases will be requested as needed throughout the contract period and as few as one each may be ordered at one time.
9. **DESCRIPTIVE LITERATURE:** If bidding other than the make(s) and model(s) specified in this bid, it is required that **COMPLETE DESCRIPTIVE TECHNICAL LITERATURE ON THE ITEM BEING BID, BE SUBMITTED WITH THE BID OR UPON REQUEST.** Such literature shall be in sufficient detail to indicate conformance with the specifications of the make(s) and model(s) specified in the bid. **FAILURE TO PROVIDE THIS DESCRIPTIVE LITERATURE IN SUFFICIENT DETAIL TO COMPLETE THE EVALUATION OF THE MAKE(S) AND MODEL(S) OFFERED IN THIS BID, WITH THIS BID OR UPON REQUEST, WILL RESULT IN DISQUALIFICATION OF BID SUBMITTED.**
- BID ITEM 31:** If bidding other than the brand and model specified in this Bid, it is required that **COMPLETE DESCRIPTIVE TECHNICAL LITERATURE WHICH CONTAINS A COMPLETE DESCRIPTION OF THE STRUCTURES, EQUIPMENT AND PARTS AS WELL AS A SHOP DRAWING AND/OR SCALE MODEL BE SUBMITTED WITH THIS BID OR UPON REQUEST. FAILURE OF THE BIDDER TO PROVIDE THIS INFORMATION WITH THE BID OR UPON REQUEST IN SUFFICIENT DETAIL TO INDICATE CONFORMANCE WITH BID SPECIFICATIONS OF THE BRAND(S) AND MODEL(S) SPECIFIED IN THE BID WILL RESULT IN DISQUALIFICATION OF BID ITEM.**
10. **COMPANY REPRESENTATIVE:** Bidder(s) should indicate, in the space provided on the Bid Summary Sheet, the name, address, telephone number, etc., of the representative who could make scheduled visits to the schools/departments and who will be available, upon request, to resolve billing and delivery problems.

VENDOR NAME: _____

BNG

The School Board of Broward County, Florida
CAFETERIA EQUIPMENT

SECTION 4, SPECIAL CONDITIONS (Continued)

11. **M/WBE UTILIZATION:** SBBC has implemented a Minority/Women Business Enterprise Program as part of the SBBC's competitive solicitation and contracting activity in accordance with School Board Policy 7007-A Administrative Procedures for The School Board of Broward County, Florida's Supplier Diversity & Outreach Program. The purpose of the program is to utilize available minority and women business enterprises (M/WBE's) with in the Board's market area to compete for the award of SBBC purchasing contracts.

An M/WBE is defined by SBBC as any legal entity, other than a joint venture, which is organized to engage in commercial transactions and which is a least 51% owned and controlled by or women minority persons. For information on M/WBE Certification, contact SBBC's Supplier Diversity & Outreach Program at 754-321-0550. SBBC's Supplier Diversity & Outreach Program works to increase the participation of Minority and Women Business Enterprises (M/WBE). It is the intent of the Supplier Diversity & Outreach Program to have a diverse group, as well as an equitable distribution of M/WBE's, participating on the award of this Bid.

12. **M/WBE UTILIZATION REPORTING:** In an effort to monitor the achievement of the M/WBE goal the Awardee(s) agrees to submit, a completed Monthly M/WBE Subcontractors Utilization Report form, **attached hereto as Exhibit "A"** and made a part of this contract. The timing of these reports must coincide with invoice submission. In addition to the Monthly M/WBE Subcontractors Utilization Report form, Awardee(s) shall also provide proof of payment made to each M/WBE Subcontractor which shall take the form of cancelled checks or check register photocopies, or any other valid form of documentation that serves to substantiate all payment amounts included in the Monthly M/WBE Subcontractor Utilization Report. The Awardee(s) understands that each M/WBE utilized for the contract must be certified by SBBC, Supplier Diversity & Outreach Program Office.

13. **INSTRUCTION MANUALS:** Awardee is required to furnish an instruction manual for each item bid. Each manual shall contain definition of equipment capabilities, technical description of equipment operation, description of malfunction identification and troubleshooting procedures.

14. **INVOICES:** Delivery copies, packing slips and invoices to SBBC **MUST** include the following to permit SBBC to verify prices with this contract and expedite the use of material. **FAILURE OF AN AWARDEE TO PROVIDE THIS INFORMATION WILL RESULT IN EITHER THE INVOICE BEING RETURNED FOR CLARIFICATION OR A DELAY IN PROCESSING SAID INVOICE FOR PAYMENT.** Invoices are to be mailed to **District Maintenance, 3810 N. W. 10th Avenue, Fort Lauderdale, Florida 33309.**

- A. Material release number OR the control number
- B. Purchase Order number
- C. Complete description of the items
- D. Itemized list prices
- E. Total dollar amount will be net

VENDOR NAME: _____
BNG

SECTION 4, SPECIAL CONDITIONS (Continued)

15. **PLACEMENT, SET-UP AND INSTALLATION:** Awardee(s) shall be responsible for inside delivery, setting in place, connecting separate items, removing cartons, installing refrigerator and warmer shelves, plug-in and remove tape when necessary. All tables, shelves, racks, etc. must be delivered completely assembled. Level equipment where necessary is required. Caulking around roll-through equipment when necessary. No electrical or plumbing hook-ups is required with the exception of ice machines. Ice machine price to include disconnect of existing ice machine and slide out of way and hook up of new machine to existing utilities. Do not remove any school board owned equipment from the premises.

The Food and Nutrition Services Department must be notified 72 hours in advance of delivery so that School Board electricians and plumbers can be notified and so that existing equipment can be disconnected and removed prior to vendor's arrival.

PLACEMENT, SET-UP AND INSTALLATION (FOR BID ITEMS 31): Awardee(s) shall be responsible for inside delivery, setting in place and connecting separate items. No electrical or plumbing hook-up is required. The installation should include, but not be limited to, removing tape, installing sneeze guards, tray rails, display cases, and other parts shipped separately, and removing and disposing all shipping materials. Awardee(s) must attach and level all separate pieces and make serving line equipment ready for use. Awardee(s) is/are not responsible for final electrical and plumbing connections. Installation shall be completed the same day as delivered. Factory start-up is required on all kettles, ovens, steamers, and combi-steamers.

16. **MODEL NUMBER CORRECTIONS:** If the **model number** for the make specified on the Bid Summary Sheet is: **a) no longer available** and has been replaced with a new updated model with new specifications, the Bidder should **submit complete descriptive literature** on the new model number; or **b) incorrect, the corrected model number should be noted** on the Bid Summary Sheet, in the space provided.

17. **MODEL UPDATES:** If, **during the contract period**, the awarded **model is discontinued** by the manufacturer, the Awardee must advise SBBC Procurement and Warehousing Services, in writing, of the non-availability of the contract item and submit complete descriptive literature for the new updated model for SBBC evaluation and approval which must meet or exceed the specifications for the original contract item. The new model must be the same make as the awarded contract item or a brand and model that is listed as an approved brand for that bid item and must be offered at the contract price or less. Samples of the replacement item(s), if requested, must be supplied for evaluation by the appropriate SBBC staff. SBBC shall not be held liable for any damages incurred to the product during evaluation.

18. **PRICE ADJUSTMENTS:** Prices offered shall remain firm through the first twelve months of the contract. A request for price adjustment, with proper documentation justifying the adjustment, may be submitted, in writing, 30 days prior to the anniversary date of the contract. Price adjustment requests will be evaluated on an annual basis thereafter. Unit price adjustments must have written approval from SBBC prior to invoicing. Any unit price adjustment invoiced without written approval from SBBC shall not be paid and the invoice returned to the Awardee for correction. Requests for price adjustments shall not exceed the percentage of change in the Consumer Price Index (CPI) for the previous twelve months of the anniversary date, but shall not exceed 3% per adjustment. The CPI will not be seasonally adjusted. SBBC reserves the right to request a reduction in contract prices equal to the percentage of change of the CPI in the event of a reduction. SBBC reserves the right to not renew any contract regardless of price considerations. Information on the CPI may be obtained from the Bureau of Labor Statistics at <http://www.bls.gov> or by contacting the Bureau directly.

VENDOR NAME: _____
BNG

The School Board of Broward County, Florida

CAFETERIA EQUIPMENT

SECTION 4, SPECIAL CONDITIONS (Continued)

19. **PROTECTION OF PROPERTY:** The Awardee shall at all times guard against damage and/or loss to the property of SBBC, and shall replace and/or repair any loss or damages unless such is caused by the SBBC. SBBC may withhold payment or make such deductions, as it might deem necessary to insure reimbursement for loss and/or damages to the property through negligence of the Awardee.
20. **ACCEPTANCE OF MATERIALS:** The material delivered under this bid shall remain the property of the Awardee until a physical inspection and actual usage of this material is made and thereafter accepted to the satisfaction of SBBC and must comply with the terms herein, and be fully in accordance with specifications. In the event the material supplied to SBBC is found to be defective or does not conform to specifications, SBBC reserves the right to cancel the order upon written request to the Awardee and return the product to Awardee, at Awardee's expense. Awardee will be responsible for pick-up of defective/rejected materials. After 30 days notification to the Awardee, if the materials are not removed, they become the property of SBBC. Awardee will be responsible for any disposition charges.
21. **U. S. DEPARTMENT OF AGRICULTURE CERTIFICATION (DEBARMENT AND SUSPENSION):** A copy of Form AD-1048 (1/92) is included as a part of these bid documents. Section 3017.510 of 7 CFR Part 3017 requires the submission of the completed Form: Certification Regarding Debarment, Suspension, Ineligibility and Voluntary Exclusion - Lower Tier Covered Transactions; for all USDA Food and Nutrition Service programs. No vendor shall be allowed to participate in any procurement activity if any federal department or agency has debarred, suspended, or otherwise excluded that vendor from participation in a procurement activity. This form should be **completed, signed** and submitted with the bid or upon request in order for the submitted bid to be considered. Every time a bid is submitted that includes reference to this Form, a new Form is required. Any bid that does not include this required Form will not be evaluated and will not be considered for award. **A signature is required on BOTH the Form AND the Invitation to Bid page.** A signature on one document cannot be substituted for the signature required on the other document. Failure to complete and sign both documents requiring signature will result in rejection of bid submitted.
22. **WARRANTY:** Manufacturer's standard warranty must be provided on all bid items. Warranty shall begin after delivery and acceptance by the user of the product. Warranty shall be stated in the spaces provided in the Bid Summary Sheet.
23. **W-9 FORMS:** All Bidders are requested to complete the attached W-9, in Section 7, Attachment 6, and submit with their bid.

VENDOR NAME: _____

BNG

The School Board of Broward County, Florida
CAFETERIA EQUIPMENT

SECTION 5, BID SUMMARY SHEET

<u>ITEM 1:</u>	<u>(TO BE AWARDED AS A GROUP)</u>	<u>UNIT PRICE</u>	<u>TOTAL COST</u>
A. 4 each	SAP #6001225 RACK, REFRIGERATOR ROLL-IN ENCLOSED NON-INSULATED Minimum Size: 64-1/2" high x 21-3/4" wide x 25-1/8" depth. Extruded frame fully welded made of non-corrosive hi-tensile aluminum, minimum thickness .10. Bottom frame one-piece construction, minimum thickness .190. For storage of (40) 18" x 26" bun pans. Interlocking extruded size walls with 1-1/2" slide spacing (corrugated walls are not acceptable). <u>Furnish with perimeter bumper, stainless steel or nickel plated door latch and (4) 5" swivel casters, two with brakes.</u> Door to be mounted on three pairs of flag-type (butt) hinges. Door swings 270°. Load capacity 200 lbs. N.S.F. approved. Unit price to include: Inside delivery, all shipping costs and complete assembly. Manufacturer's standard warranty will apply. Approved Brands: Crescor Model 150-1840D, Winholt EC1840-CTLPURC/LC/PEB or other brands and models meeting bid specifications	\$ _____	/ea \$ _____
	Brand Offered: _____		
	Model Offered: _____		
	Warranty Period: _____		
	Delivery (days ARO): _____		

VENDOR NAME: _____
BNG

The School Board of Broward County, Florida
CAFETERIA EQUIPMENT

SECTION 5, BID SUMMARY SHEET

		<u>UNIT PRICE</u>	<u>TOTAL COST</u>
<u>ITEM 1:</u>	<u>(TO BE AWARDED AS A GROUP) - CONTINUED</u>		
B.	15 each	\$ _____	/ea \$ _____
<p>SAP #6000129 Minimum Size: 69-3/4" x 22-7/16" wide x 29-5/8" depth. Super heavy-duty, non-corrosive fully welded construction. Framework of structural Hi-Tensile aluminum extrusions or type 6063 aluminum alloy. Tubing mechanically attached to aluminum runners and welded to form vertical uprights. Casters are attached to heavy duty wheel channel extrusion for extra stability. Runners are 2-1/4" extruded aluminum. Unit designed to accommodate a minimum of nineteen (19) each 18" x 20" sheet pans. Bottom of pan rests on 2-1/4" extruded aluminum .090 thick runners on 3" centers. Runner or pan support is welded to vertical uprights. Four (4) 5" heavy duty swivel casters, two with brakes. For storage of (20) 18" x 26" bun pans on bottom pan angle ledges on 3" centers. Posts are made of extruded aluminum, cross supports welded into frame. Load capacity 800 lbs. N.S.F. approved. Unit price to include: Inside delivery, all shipping costs and complete assembly. Manufacturer's standard warranty applies. Approved Brands: Crescor Model 207-1820-SD, Win-Holt AL-1820/HD/LC, or other brands meeting bid specifications</p> <p>Brand Offered: _____ Model Offered: _____ Warranty Period: _____ Delivery (days ARO): _____</p>			

VENDOR NAME: _____
BNG

The School Board of Broward County, Florida
CAFETERIA EQUIPMENT

SECTION 5, BID SUMMARY SHEET (Continued)

		<u>UNIT PRICE</u>	<u>TOTAL COST</u>
<u>ITEM 1:</u>	<u>(TO BE AWARDED AS A GROUP) - CONTINUED</u>		
C.	10 each SAP #6001226 RACK, REFRIGERATOR ROLL-IN, OPEN Minimum size: 64-1/2" high x 21-1/4" wide x 25-1/8" depth. Constructed of non-corrosive high tensile aluminum. Fully welded framework for rigidity and strength. Extruded angle ledge pan supports welded in place. Posts and cross supports to be minimum thickness of .125. Heavy-duty 5" swivel plate casters, two with brakes. Accommodates (11) 18" x 26" pans or (22) 14" x 18" trays. Slide spacing 5-1/8". Load capacity 200 lbs. Unit price to include: Inside delivery and complete assembly. Manufacturer's standard warranty will apply. Approved Brands: Crescor Model 207-1818-C, Winholt ALREF1118/64E/XB/LC or other brands meeting bid specifications Brand Offered: _____ Model Offered: _____ Warranty Period: _____ Delivery (days ARO): _____	\$ _____	/ea \$ _____
TOTAL BID ITEM 1 (A – C inclusive).....			\$ _____

VENDOR NAME: _____
BNG

The School Board of Broward County, Florida
CAFETERIA EQUIPMENT

SECTION 5, BID SUMMARY SHEET (Continued)

		<u>UNIT PRICE</u>	<u>TOTAL COST</u>
<u>ITEM 2:</u>	50 each		
	SAP #6000084		
	RACKS, DUNNAGE	\$ _____	/ea \$ _____
	12" high x 21" or 22" deep x 48" wide. One piece, polyethylene construction. Foamed in place for structural strength. Slotted top for air circulation around stored products. N.S.F. approved. Cleaning clearance underneath 8-3/4". Load capacity minimum 1500 pounds. Manufacturer's standard warranty will apply.		
	Approved Brands: Cambro Model DRS-480, InterMetro Model HP2248PD, Continental Model 5848, Winholt PLSQ-4-1222 ONLY.		
	Brand Offered: _____		
	Model Offered: _____		
	Warranty Period: _____		
	Delivery (days ARO): _____		

VENDOR NAME: _____
BNG

The School Board of Broward County, Florida
CAFETERIA EQUIPMENT

SECTION 5, BID SUMMARY SHEET (Continued)

<u>ITEM 3:</u>	<u>(TO BE AWARDED AS A GROUP)</u>	<u>UNIT PRICE</u>	<u>TOTAL COST</u>
	SHELVING, ADJUSTABLE FOR DRY STORAGE Wire shelving, rust resistant epoxy, open wire design. Constructed of heavy gauge carbon steel with a coating process that creates a corrosion resistant finish. Coating finish contains Microban antimicrobial protection from bacteria, mold, etc. Shelves adjustable on 1" increments. Weight capacity of entire shelf 36" or 48" with equal distribution of weight in minimum of 1500 lbs. 10-year limited warranty against rust. Adjustable levelers available for post feet. NSF approved. Unit price to include: Inside delivery, uncrating, removal of packaging materials, four-tier assembly, all shipping costs and installation required. First shelf to be 7" AFF and remaining shelves to be spaced equally. Approved Brands: InterMetro Metro-Seal, Eagle Group Eaglegard, Amco, or other brands meeting bid specifications		
A.	25 each SAP #6001233, SHELF , 21" Wide X 36" Long	\$ _____	/ea \$ _____
B.	50 each SAP# _____, SHELF , 18" Wide x 36" Long	\$ _____	/ea \$ _____
C.	50 each SAP# _____, SHELF , 18" Wide x 42" Long	\$ _____	/ea \$ _____
D.	100 each SAP# _____, SHELF , 21" Wide x 42" Long	\$ _____	/ea \$ _____
E.	100 each SAP #6000136, SHELF , 21" Wide X 48" Long (BR)	\$ _____	/ea \$ _____
F.	50 each SAP# _____ SHELF , 18" Wide x 48" Long	\$ _____	/ea \$ _____
G.	100 each SAP #6000137, POST 63" High	\$ _____	/ea \$ _____
H.	155 each SAP #6004820, POST 75" High	\$ _____	/ea \$ _____

Brand Offered: _____
Warranty Period: _____
Delivery (days ARO): _____

TOTAL BID ITEM 3 (A – H inclusive) \$ _____

VENDOR NAME: _____
BNG

The School Board of Broward County, Florida
CAFETERIA EQUIPMENT

SECTION 5, BID SUMMARY SHEET (Continued)

		<u>(TO BE AWARDED AS A GROUP)</u>	<u>UNIT PRICE</u>	<u>TOTAL COST</u>
ITEM 4:				
A.	150 each	SAP #6000095 UTILITY CART, THREE SHELVES, SMALL SIZE Minimum size: 42" high x 18" wide x 32" long. Minimum Shelf size: 32" long x 18" wide and have fully hemmed lips turned down on 4 sides. All shelves with lips turned down. Made from extruded stainless steel tubing welded to stainless steel sheets, 16 gauge 304 stainless steel. Single loop handle made from one piece square stainless tubing welded to shelves. <u>(4) 5" polyurethane swivel casters required, two with brakes.</u> 800 lbs. of load capacity. N.S.F. approved. Unit price to include inside delivery and complete assembly. Two (2) year warranty on carts and wheels. Approved Brands: Win-Holt Model SSUC-3-1832/1H/42H/4LD or other brands meeting bid specifications. Brand Offered: _____ Model Offered: _____ Warranty Period: _____ Delivery (days ARO): _____	\$ _____	/ea \$ _____
B.	200 each	SAP #6000095 UTILITY CART, THREE SHELVES, LARGE SIZE Minimum size: 42" high x 21" wide x 33" long. Minimum Shelf size: 33" long x 21" wide and have fully hemmed lips turned down on all 4 sides. All shelves with lips turned down. Made from extruded stainless steel tubing welded to stainless steel sheets, 16 gauge 304 stainless steel. Single loop handle made from one piece square stainless tubing welded to shelves. <u>(4) 5" polyurethane swivel casters required, two with brakes.</u> 800 lbs. of load capacity. N.S.F. approved. Unit price to include inside delivery and complete assembly. Two (2) year warranty on carts and wheels. Approved Brands: Win-Holt Model SSUC-3-2133/1H/42H/4LD or other brands meeting bid specifications. Brand Offered: _____ Model Offered: _____ Warranty Period: _____ Delivery (days ARO): _____	\$ _____	/ea \$ _____

VENDOR NAME: _____
BNG

The School Board of Broward County, Florida
CAFETERIA EQUIPMENT

SECTION 5, BID SUMMARY SHEET (Continued)

		<u>(TO BE AWARDED AS A GROUP)</u>	<u>UNIT PRICE</u>	<u>TOTAL COST</u>
<u>ITEM 4:</u>				
C.	5 each	SAP #6001107 STAND, UTILITY Minimum size: 29" high x 33" wide x 25" long. Shelf size: 24" long x 32" wide. Utility stand is designed for holding, storing and transporting mixers, slicers, grinders and other types of small appliances and accessories. Stand has 18 gauge reinforced top supported by rigid 12 gauge angle legs. (4) 4" swivel casters are required, two with brakes. Easy to clean and sanitize. NSF approved. Unit price to include inside delivery and complete assembly of stand. Manufacturer's standard warranty will apply. Approved Brands: Lakeside Model 518, Seco Model SS-16-3033-AX or other brands meeting bid specifications Brand Offered: _____ Model Offered: _____ Warranty Period: _____ Delivery (days ARO): _____	\$ _____	/ea \$ _____
TOTAL BID ITEM 5 (A – C inclusive).....			\$ _____	

<u>ITEM 5:</u>				
A.	8 each	SAP #6001148 CART, UTILITY – SMALL Minimum Size: 35 1/2" high x 18 5/6" wide x 31 1/2" long. Shelves to be 3-tier polyethylene, injection molded and 4 chrome plated posts. Shelves designed to resist staining and wipe clean easily. Handle shelf will have integrated utility tray and coved corners. Flat shelves built in 3" cutaway for additional legroom. Sturdy construction: rated at 150 lbs. per shelf. Easy no-tool assembly. (4) 4" non-marking swivel casters. Colors available in black, gray, blue. Cart to include nominal labels for easy identification. Blue model has Microban antimicrobial product protection. Manufacturer's standard warranty will apply. NSF approved. Unit price to include inside delivery and complete assembly. Approved Brands: InterMetro Model MY1627-34 or other brands meeting bid specifications (Color code may be noted as last character(s) of model number) Brand Offered: _____ Model Offered: _____ Colors Available: _____ Warranty Period: _____ Delivery (days ARO): _____	\$ _____	/ea \$ _____

VENDOR NAME: _____
BNG

The School Board of Broward County, Florida
CAFETERIA EQUIPMENT

SECTION 5, BID SUMMARY SHEET

		<u>UNIT PRICE</u>	<u>TOTAL COST</u>
ITEM 5:	<u>(TO BE AWARDED AS A GROUP) - Continued</u>		
B.	10 each	\$ _____	/ea \$ _____
	<p>SAP #6000113 CART, UTILITY, THREE SHELVES – LARGE Minimum size: 35 ½" high x 27 11/16" wide x 40 ¼" long. Shelves to be 3-tier polyethylene, injection molded and 4 chrome plated posts. Shelves designed to resist staining and wipe clean easily. Handle shelf will have integrated utility tray and coved corners. Flat shelves built in 3" cutaway for additional legroom. Sturdy construction: rated at 150 lbs. per shelf. Easy no-tool assembly. (4) 4" non-marking swivel casters. Colors available in black, gray, blue. Cart to include nominal labels for easy identification. Blue model has Microban antimicrobial product protection. Manufacturer's standard warranty will apply. NSF approved. Unit price to include inside delivery and complete assembly. Approved Brands: InterMetro Model MY 2636-34 or other brands meeting bid specifications (Color code may be noted as last character(s) of model number)</p> <p>Brand Offered: _____ Model Offered: _____ Colors Available: _____ Warranty Period: _____ Delivery (days ARO): _____</p>		
C.	12 each	\$ _____	/ea \$ _____
	<p>SAP #6000111 CART, UTILITY, THREE SHELVES – MEDIUM Minimum size: 35 1/2" high x 23 7/16" wide x 34 3/8" long. Shelves to be 3-tier polyethylene, injection molded and 4 chrome plated posts. Shelves designed to resist staining and wipe clean easily. Handle shelf will have integrated utility tray and coved corners. Flat shelves built in 3" cutaway for additional legroom. Sturdy construction: rated at 150 lbs. per shelf. Impact-resistant surface will not chip, peel or dent. Easy no-tool assembly. (4) 4" non-marking swivel casters. Colors available in black, gray, and blue. Cart to include nominal labels for easy identification. Blue model has Microban antimicrobial product protection. Manufacturer's standard warranty will apply. NSF approved. Unit price to include inside delivery and complete assembly. Approved Brands: InterMetro Model MY2030-34 or other brands meeting bid specifications</p> <p>Brand Offered: _____ Model Offered: _____ Colors Available: _____ Warranty Period: _____ Delivery (days ARO): _____</p>		
TOTAL BID ITEM 5 (A – C inclusive)		\$ _____	

VENDOR NAME: _____
BNG

The School Board of Broward County, Florida
CAFETERIA EQUIPMENT

SECTION 5, BID SUMMARY SHEET (Continued)

		<u>UNIT PRICE</u>	<u>TOTAL COST</u>
ITEM 6:	(TO BE AWARDED AS A GROUP)		
A.	60 each	\$ _____	/ea \$ _____
	SAP #6000068		
	TABLE, UTILITY – 5’L x 2.5’W x 3”H		
	<u>See Illustration 6A. 5' long x 2-1/2' wide x 3' high. Tops to be 14 gauge stainless steel with channel edges all sides, no splash. Bull nose edge with marine edge. 18 gauge stainless steel undershelf. Stainless steel legs on casters. One stainless steel roller bearing drawer 20" x 20" x 5" deep. Mounted on 5" swivel number 5-40 126 J & J or equivalent casters, two with vertilok brakes. Overall table top height three feet. All Stainless steel to be 18/8 number 304 with a number four polish. Top 14 gauge, under shelf 18-gauge. Unit must be NSF approved. Unit price to include inside delivery, all shipping costs and complete assembly. NOTE: For all custom made utility tables, a complete drawing, illustrating the following information, but not limited to, dimensions, sizes, type of materials and accessories, must be furnished for evaluation purposes. Failure to furnish a complete drawing will result in disqualification of bid item. Manufacturer's warranty will apply. Inside delivery and set-up required.</u>		
	Approved Brands: SPG International Model 5-SL-SLS Table with TAC 1-4 casters and TAC 2020-S drawer, Elkay Custom Deluxe Spec-Line Series, Advanced Tabco SS-306, Eagle Group Model T3060SE w/casters & drawer ONLY.		
	Brand Offered: _____		
	Model Offered: _____		
	Warranty Period: _____		
	Delivery (days ARO): _____		

VENDOR NAME: _____
BNG

The School Board of Broward County, Florida
CAFETERIA EQUIPMENT

SECTION 5, BID SUMMARY SHEET (Continued)

		<u>UNIT PRICE</u>	<u>TOTAL COST</u>
ITEM 6:	(TO BE AWARDED AS A GROUP) – Continued		
B.	50 each	\$ _____	/ea \$ _____
	<p>SAP #6001110</p> <p>TABLE, UTILITY – 6’L x 2.5’W x 3”H</p> <p>See Illustration 6B. 6' long x 2-1/2' wide x 3' high. Tops to be 14 gauge stainless steel with channel edges all sides no splash. Stainless steel legs on casters. Bull nose edge with marine edge. 18 gauge stainless steel undershelf</p> <p>One stainless steel roller bearing drawer 20" x 20" x 5" deep. Mounted on 5" swivel number 5-40 126 J & J casters, two with vertilok brakes. Overall table top height three feet. All Stainless steel to be 18/8 number 304 with a number four polish. Top 14 gauge, under shelf 18 gauge. Unit must be NSF approved. Unit price to include inside delivery, all shipping costs and complete assembly. <u>NOTE: For all custom made utility tables, a complete drawing, illustrating the following information, but not limited to, dimensions, sizes, type of materials and accessories, must be furnished for evaluation purposes. Failure to furnish a complete drawing will result in disqualification of bid item.</u> Manufacturer's standard warranty. Inside delivery and set-up required.</p> <p>Approved Brand: SPG International Model 6-SL-SLS Table with TAC 1-4 casters and TAC 2020-S drawer, Elkay Custom Spec Line, Eagle Group Model T3072SE w/casters & drawer ONLY.</p> <p>Brand Offered: _____</p> <p>Model Offered: _____</p> <p>Warranty Period: _____</p> <p>Delivery (days ARO): _____</p>		
TOTAL BID ITEM 6 (A – B inclusive).....			\$ _____

VENDOR NAME: _____
BNG

The School Board of Broward County, Florida
CAFETERIA EQUIPMENT

SECTION 5, BID SUMMARY SHEET (Continued)

		<u>UNIT PRICE</u>	<u>TOTAL COST</u>
ITEM 7: (TO BE AWARDED AS A GROUP)			
A.	30 each	SAP #6000073 TABLE, WORK – STAINLESS STEEL – 60” LONG – NO CASTERS <u>See Illustration 7A.</u> Top minimum 14 gauge stainless, under-shelf minimum 18 gauge stainless, minimum 60" long x 24" wide x 35" high. Stainless steel legs, <u>no casters</u> . Type 304 stainless steel with under-shelf. NSF approved. Unit price to include inside delivery and complete assembly. Manufacturer's standard warranty will apply. Inside delivery and set-up required. Approved Brand: Eagle Model T-2460SE, Gamenza Model T2460 or other brands meeting bid specifications	\$ _____ /ea \$ _____
Brand Offered: _____			
Model Offered: _____			
Warranty Period: _____			
Delivery (days ARO): _____			
B.	40 each	SAP #6000074 TABLE, WORK - STAINLESS STEEL – 48” LONG – NO CASTERS <u>See Illustration 7B.</u> Top minimum 14 gauge stainless steel, under shelf minimum 18 gauge stainless steel, minimum 48" long x 24" wide x 35" high. Stainless Steel legs, <u>no casters</u> . Type 304 stainless steel with under shelf. NSF approved. Unit price to include inside delivery and complete assembly. Manufacturer's standard warranty will apply. Inside delivery and set-up required. Approved Brand: Eagle Model T-2448SE, Gamenza Model T4824 or other brands meeting bid specifications	\$ _____ /ea \$ _____
Brand Offered: _____			
Model Offered: _____			
Warranty Period: _____			
Delivery (days ARO): _____			

VENDOR NAME: _____
BNG

The School Board of Broward County, Florida
CAFETERIA EQUIPMENT

SECTION 5, BID SUMMARY SHEET (Continued)

		<u>UNIT PRICE</u>	<u>TOTAL COST</u>
<u>ITEM 7: (TO BE AWARDED AS A GROUP) – CONTINUED</u>			
C.	20 each	SAP #6001111 TABLE, WORK - STAINLESS STEEL – 48” LONG – WITH CASTERS <u>See Illustration 7C.</u> Top minimum 14 gauge stainless steel, under shelf minimum 18 gauge stainless steel, minimum 48” long x 24” wide x 35” high. Stainless Steel legs and 5” swivel, locking casters. Type 304 stainless steel with under shelf. NSF approved. Unit price to include inside delivery and complete assembly. Manufacturer’s standard warranty will apply. Inside delivery and set-up required. Approved Brand: Eagle Model T-2448SE, Gamenza Model T-4824-C or other brands meeting bid specifications	\$ _____ /ea \$ _____
Brand Offered: _____			
Model Offered: _____			
Warranty Period: _____			
Delivery (days ARO): _____			
D.	30 each	SAP #6000075 TABLE, WORK - STAINLESS STEEL – 60” LONG – NO CASTERS <u>See Illustration 7D.</u> Top minimum 14 gauge stainless steel, under shelf minimum 18 gauge stainless steel, minimum 60” long x 30” wide x 35” high. Stainless Steel legs, <u>no casters.</u> Type 304 stainless steel with under shelf. NSF approved. Unit price to include inside delivery and complete assembly. Manufacturer’s standard warranty will apply. Inside delivery and set-up required. Approved Brand: Eagle Model T-3060SE, Gamenza Model T6030 or other brands meeting bid specifications	\$ _____ /ea \$ _____
Brand Offered: _____			
Model Offered: _____			
Warranty Period: _____			
Delivery (days ARO): _____			

VENDOR NAME: _____
BNG

The School Board of Broward County, Florida
CAFETERIA EQUIPMENT

SECTION 5, BID SUMMARY SHEET (Continued)

		<u>UNIT PRICE</u>	<u>TOTAL COST</u>
ITEM 7: (TO BE AWARDED AS A GROUP) – CONTINUED			
E.	20 each	SAP #6000076 TABLE, WORK - STAINLESS STEEL – 72” LONG – NO CASTERS <u>See Illustration 7E.</u> Top minimum 14 gauge stainless steel, under shelf minimum 18 gauge stainless steel, minimum 72” long x 30” wide x 35” high. Stainless Steel legs, no casters. Type 304 stainless steel with under shelf. NSF approved. Unit price to include inside delivery and complete assembly. Manufacturer’s standard warranty will apply. Inside delivery and set-up required. Approved Brand: Eagle Model T-3072SE, Gamenza Model T7230 or other brands meeting bid specifications	\$ _____ /ea \$ _____
Brand Offered: _____			
Model Offered: _____			
Warranty Period: _____			
Delivery (days ARO): _____			
F.	1 each	SAP #6001112 TABLE, WORK - STAINLESS STEEL – 84” LONG – NO CASTERS <u>See Illustration 7F.</u> Top minimum 14 gauge stainless steel, under shelf minimum 18 gauge stainless steel, minimum 84” long x 30” wide x 35” high. Stainless Steel legs, no casters. Type 304 stainless steel with under shelf. NSF approved. Unit price to include inside delivery and complete assembly. Manufacturer’s standard warranty will apply. Inside delivery and set-up required. Approved Brand: Eagle Model T-3084SE, Gamenza Model T8430 or other brands meeting bid specifications	\$ _____ /ea \$ _____
Brand Offered: _____			
Model Offered: _____			
Warranty Period: _____			
Delivery (days ARO): _____			

VENDOR NAME: _____
BNG

The School Board of Broward County, Florida
CAFETERIA EQUIPMENT

SECTION 5, BID SUMMARY SHEET (Continued)

		<u>UNIT PRICE</u>	<u>TOTAL COST</u>
ITEM 7: (TO BE AWARDED AS A GROUP) – CONTINUED			
G.	30 each	SAP # _____ \$ _____	/ea \$ _____
<p>TABLE, WORK - STAINLESS STEEL – 48” LONG – WITH CASTERS <u>See Illustration 7C.</u> Top minimum 14 gauge stainless steel, under shelf minimum 18 gauge stainless steel, minimum 48” long x 30” wide x 35” high. Stainless Steel legs and 5” swivel, locking casters. Type 304 stainless steel with under shelf. NSF approved. Unit price to include inside delivery and complete assembly. Manufacturer’s standard warranty will apply. Inside delivery and set-up required. Approved Brand: Eagle Model T-3048SE, Gamenza Model T-4830-C or other brands meeting bid specifications</p> <p>Brand Offered: _____ Model Offered: _____ Warranty Period: _____ Delivery (days ARO): _____</p>			
H.	30 each	SAP # _____ \$ _____	/ea \$ _____
<p>TABLE, WORK - STAINLESS STEEL – 36” LONG – WITH CASTERS <u>See Illustration 7C.</u> Top minimum 14 gauge stainless steel, under shelf minimum 18 gauge stainless steel, minimum 36” long x 24” wide x 35” high. Stainless Steel legs and 5” swivel, locking casters. Type 304 stainless steel with under shelf. NSF approved. Unit price to include inside delivery and complete assembly. Manufacturer’s standard warranty will apply. Inside delivery and set-up required. Approved Brand: Eagle Model T-2436SE, Gamenza Model T-3624-C or other brands meeting bid specifications</p> <p>Brand Offered: _____ Model Offered: _____ Warranty Period: _____ Delivery (days ARO): _____</p>			

VENDOR NAME: _____
BNG

The School Board of Broward County, Florida
CAFETERIA EQUIPMENT

SECTION 5, BID SUMMARY SHEET (Continued)

		<u>UNIT PRICE</u>	<u>TOTAL COST</u>
ITEM 7: (TO BE AWARDED AS A GROUP) – CONTINUED			
I.	20 each	SAP # _____ \$ _____	/ea \$ _____
<p>TABLE, WORK - STAINLESS STEEL – 42” LONG – WITH CASTERS <u>See Illustration 7C.</u> Top minimum 14 gauge stainless steel, under shelf minimum 18 gauge stainless steel, minimum 42” long x 30” wide x 35” high. Stainless Steel legs and 5” swivel, locking casters. Type 304 stainless steel with under shelf. NSF approved. Unit price to include inside delivery and complete assembly. Manufacturer’s standard warranty will apply. Inside delivery and set-up required. Approved Brand: Eagle Model T-3042SE, Gamenza Model T-4230-C or other brands meeting bid specific Brand Offered: _____ Model Offered: _____ Warranty Period: _____ Delivery (days ARO): _____</p>			
J.	30 each	SAP # _____ \$ _____	/ea \$ _____
<p>TABLE, WORK - STAINLESS STEEL – 36” LONG – WITH CASTERS <u>See Illustration 7C.</u> Top minimum 14 gauge stainless steel, under shelf minimum 18 gauge stainless steel, minimum 36” long x 30” wide x 35” high. Stainless Steel legs and 5” swivel, locking casters. Type 304 stainless steel with under shelf. NSF approved. Unit price to include inside delivery and complete assembly. Manufacturer’s standard warranty will apply. Inside delivery and set-up required. Approved Brand: Eagle Model T-3036SE, Gamenza Model T-3630-C or other brands meeting bid specifications Brand Offered: _____ Model Offered: _____ Warranty Period: _____ Delivery (days ARO): _____</p>			

VENDOR NAME: _____
BNG

The School Board of Broward County, Florida
CAFETERIA EQUIPMENT

SECTION 5, BID SUMMARY SHEET (Continued)

		<u>UNIT PRICE</u>	<u>TOTAL COST</u>
ITEM 7: (TO BE AWARDED AS A GROUP) – CONTINUED			
K.	50 each	SAP #6000073 TABLE, WORK – STAINLESS STEEL – 42” LONG – NO CASTERS See Illustration 7A. Top minimum 14 gauge stainless, under-shelf minimum 18 gauge stainless, minimum 42" long x 24" wide x 35" high. Stainless steel legs, <u>no casters</u> . Type 304 stainless steel with under-shelf. NSF approved. Unit price to include inside delivery and complete assembly. Manufacturer's standard warranty will apply. Inside delivery and set-up required. Approved Brand: Eagle Model T-2442SE, Gamenza Model T-2442 or other brands meeting bid specifications Brand Offered: _____ Model Offered: _____ Warranty Period: _____ Delivery (days ARO): _____	\$ _____ /ea \$ _____
L.	30 each	SAP #6000073 TABLE, WORK – STAINLESS STEEL – 60” LONG – WITH CASTERS See Illustration 7A. Top minimum 14 gauge stainless, under-shelf minimum 18 gauge stainless, minimum 60" long x 24" wide x 35" high. Stainless Steel legs and 5" swivel, locking casters. Type 304 stainless steel with under-shelf. NSF approved. Unit price to include inside delivery and complete assembly. Manufacturer's standard warranty will apply. Inside delivery and set-up required. Approved Brand: Eagle Model T-2460SE, Gamenza Model T-2460-C or other brands meeting bid specifications Brand Offered: _____ Model Offered: _____ Warranty Period: _____ Delivery (days ARO): _____	\$ _____ /ea \$ _____

VENDOR NAME: _____
BNG

The School Board of Broward County, Florida
CAFETERIA EQUIPMENT

SECTION 5, BID SUMMARY SHEET (Continued)

		<u>UNIT PRICE</u>	<u>TOTAL COST</u>
<u>ITEM 7:</u>	<u>(TO BE AWARDED AS A GROUP) – CONTINUED</u>		
M. 30 each	SAP# _____	\$ _____	/ea \$ _____
	TABLE, WORK – STAINLESS STEEL – 48” LONG – NO CASTERS		
	See Illustration 7A. Top minimum 14 gauge stainless, under-shelf minimum 18 gauge stainless, minimum 48" long x 30" wide x 35" high. Stainless steel legs, <u>no casters</u> . Type 304 stainless steel with under-shelf. NSF approved. Unit price to include inside delivery and complete assembly. Manufacturer’s standard warranty will apply. Inside delivery and set-up required.		
	Approved Brand: Eagle Model T-3048SE, Gamenza Model T-3048 or other brands meeting bid specifications		
	Brand Offered: _____		
	Model Offered: _____		
	Warranty Period: _____		
	Delivery (days ARO): _____		
TOTAL BID ITEM 7 (A – M inclusive)			\$ _____

VENDOR NAME: _____
BNG

The School Board of Broward County, Florida
CAFETERIA EQUIPMENT

SECTION 5, BID SUMMARY SHEET (Continued)

	<u>UNIT PRICE</u>	<u>TOTAL COST</u>
ITEM 8: 4 each SAP #6001106 TABLE FOR BAKER'S SCALE <u>See Illustration 8.</u> Counter-top model, 24" x 24" square. <u>All welded stainless construction.</u> 14-gauge 304 stainless steel top with marine edge. Top reinforced with stainless steel hat channels. Undershelf 14 gauge type 304 stainless steel. Stainless steel gussets. Legs to be 1-5/8" round stainless steel tubing with 1" adjustable stainless steel clad feet. Legs inserted and welded into hat channel. Manufacturer's standard warranty will apply. Unit price to include complete assembly and inside delivery (placement of table). Inside delivery and set-up required. Approved Brand: Winholt EX/MX2424/14GA or other brands meeting bid specifications	\$ _____	/ea \$ _____
Brand Offered: _____		
Model Offered: _____		
Warranty Period: _____		
Delivery (days ARO): _____		

VENDOR NAME: _____
BNG

The School Board of Broward County, Florida
CAFETERIA EQUIPMENT

SECTION 5, BID SUMMARY SHEET (Continued)

		<u>UNIT PRICE</u>	<u>TOTAL COST</u>
ITEM 9:	<u>(TO BE AWARDED AS A GROUP)</u>		
A.	3 units SAP #6001079 OVEN, STACK PIZZA CONVEYOR – 120-208 VOLT	\$ _____	/unit \$ _____

Two ovens stacked with separate electrical controls per oven. High production induction or jet air conveyor oven. Jets of high velocity hot air delivered to food. Oven to have adjustable forced air diffusers or air fingers to distribute heat evenly. Digital temperature display and conveyor speed controls. Controls must have an emergency stop switch. Stainless steel interior. Each separate cooking section to have a minimum chamber clearance of 18-3/4" wide X 3-1/2" high to accommodate 18" X 26" sheet pans. Minimum 18" wide stainless steel wire belt. Adjustable conveyor speed and reversible direction. Overall footprint of oven not to exceed: 70" long X 47" wide. Oven must include:

- Stainless steel removable exit shelf – two per each oven
- Stainless steel entrance shelf – two per each oven
- Stainless removable crumb trays two per each oven
- Type 304 stainless steel stand, 1" square tubing, four swivel/locking casters
- Conveyor ovens stacked at factory and shipped fully assembled.

Electrical: 120-208V/60 Hz/3 Phase. 36-38 amps (approx.) per oven.

Warranty: Two year manufacturer's warranty, all parts and labor must be included in the unit price. Demonstration of equipment shall be required, at school cafeteria location, by a factory representative, for a minimum of one lunch period after delivery of equipment. **UL listed.** Price must include inside delivery and complete operational setup and demonstration.

Approved Brands: Lincoln Model 1132 w/part #1121-1 and 2 each part #1140 with stainless steel interior or other brands meeting bid specifications

Brand Offered: _____
Model Offered: _____
Warranty Period: _____
Delivery (days ARO): _____

B.	2 units SAP #6002199 OVEN, STACK PIZZA CONVEYOR – 480 VOLT Same as 9A, except 480 volt, 3 Phase. Approved Brands: Lincoln Model 1135 w/part #1121-1 and 2 each part #1140 or other brands meeting bid specifications	\$ _____	/unit \$ _____
	Brand Offered: _____ Model Offered: _____ Warranty Period: _____ Delivery (days ARO): _____		

TOTAL BID ITEM 9 (A – B inclusive)..... \$ _____

VENDOR NAME: _____
BNG

The School Board of Broward County, Florida
CAFETERIA EQUIPMENT

SECTION 5, BID SUMMARY SHEET (Continued)

		<u>UNIT PRICE</u>	<u>TOTAL COST</u>
ITEM 10: (TO BE AWARDED AS A GROUP)			
A.	20 each	SAP #6001252 COOLER, MILK – 8 CRATES Drop front style cooler, all stainless steel Type 300 stainless front, top, sides, doors and interior. Storage capacity 8 crates (13" x 13" x 11"). Stainless steel floor on top of minimum of 18 gauge galvanized steel with heavy-duty floor rack. Foamed-in-place polyurethane minimum 1-5/8" high-density insulated door. Self contained refrigeration system, no plumbing required. 4" – 5" heavy-duty swivel casters, 2 with brakes. Cylinder lock or pad lock for security. Nema 5-15P cord/cap, minimum cord length 8 feet. NSF and UL approved. Warranty: Two year manufacturer's warranty, all parts and labor, 5 years on compressor must be included in unit price. Price must include inside delivery and complete operational setup. Approved Brands: True Mfg. Model TMC-34-S with s/s interior, Mod-U-Serve Model MCT-SM1, Norlake Model ARO82SSS/O, Beverage Air Model SMF34-S ONLY. Brand Offered: _____ Model Offered: _____ Warranty Period: _____ Delivery (days ARO): _____	\$ _____ /ea \$ _____
B.	20 each	SAP #6001253 COOLER, MILK – 12 CRATES Drop front style cooler, all stainless steel Type 300 stainless front, top, sides, doors and interior. Storage capacity 12 crates (13" x 13" x 11"). Stainless steel floor on top of minimum of 18 gauge galvanized steel with heavy-duty floor rack. Foamed-in-place polyurethane minimum 1-5/8" high-density insulated door. Self contained refrigeration system, no plumbing required. 4" – 5" heavy-duty swivel casters, 2 with brakes. Cylinder lock or pad lock for security. Nema 5-15P cord/cap, minimum cord length 8 feet. NSF and UL approved. Warranty: Two year manufacturer's warranty, all parts and labor, 5 years on compressor must be included in unit price. Price must include inside delivery and complete operational setup. Approved Brands: True Mfg. Model TMC-49-S with s/s interior, Mod-U-Serve Model MCT-SM2, Norlake Model ARO122SSS/O, Beverage Air Model SMF49-S ONLY. Brand Offered: _____ Model Offered: _____ Warranty Period: _____ Delivery (days ARO): _____	\$ _____ /ea \$ _____

VENDOR NAME: _____
BNG

The School Board of Broward County, Florida
CAFETERIA EQUIPMENT

SECTION 5, BID SUMMARY SHEET (Continued)

		<u>UNIT PRICE</u>	<u>TOTAL COST</u>
ITEM 10:	<u>(TO BE AWARDED AS A GROUP) – Continued</u>		
C.	5 each	\$ _____	/ea \$ _____
	<p>SAP #6001335</p> <p>COOLER MILK – 16 CRATES</p> <p>Drop front style cooler, all stainless steel Type 300 stainless front, top, sides, doors and interior. Storage capacity 16 crates (13" x 13" x 11"). Stainless steel floor on top of minimum of 18 gauge galvanized steel with heavy-duty floor rack. Foamed-in-place polyurethane minimum 1-5/8" high-density insulated door. Self contained refrigeration system, no plumbing required. 4" – 5" heavy-duty swivel casters, 2 with brakes. Cylinder lock or pad lock for security. Nema 5-15P cord/cap, minimum cord length 8 feet. NSF and UL approved. Warranty: Two year manufacturer's warranty, all parts and labor, 5 years on compressor must be included in the unit price. Price must include inside delivery and complete operational setup.</p> <p>Approved Brands: True Mfg. Model TMC-58-S with s/s interior, Mod-U-Serve Model MCT-SM3, Norlake Model ARO162SSS/O, Beverage Air Model SMF58-S ONLY.</p> <p>Brand Offered: _____</p> <p>Model Offered: _____</p> <p>Warranty Period: _____</p> <p>Delivery (days ARO): _____</p>		
TOTAL BID ITEM 10 (A – C inclusive)			\$ _____

VENDOR NAME: _____
BNG

The School Board of Broward County, Florida
CAFETERIA EQUIPMENT

SECTION 5, BID SUMMARY SHEET (Continued)

		<u>UNIT PRICE</u>	<u>TOTAL COST</u>
ITEM 11: (TO BE AWARDED AS A GROUP)			
A.	15 each	\$ _____	/ea \$ _____
	SAP #6002182 RANGE, EXPANDO COOKING – ELECTRIC – 208 VOLT All-purpose two-burner range. Front, exterior bottom including base channel, and fastening devices to be all stainless steel. Top shall have two 9" solid, round cast iron hot plates with formed tubular heating element. Grease troughs on front and back of cooking area or porcelain enamel grease drawer under cook top. Internal limit overload protection available only on 208 volt units. Working height to be 36" or 37" high x 12" wide x 36" to 38" front to rear. 208 volt, one phase. Service manual, parts list, and wiring diagrams must accompany each delivered unit. Warranty: Two-year manufacturer's warranty, all parts and labor must be included in the unit price. <u>Unit Price must include uncrate, set in place & level, remove plastic, provide service manuals, schematic diagrams and on-site demonstration for each delivered unit.</u> Approved Brand: Vulcan-Hart Model E12FP or other brands meeting bid specifications Brand Offered: _____ Model Offered: _____ Warranty Period: _____ Delivery (days ARO): _____		
B.	2 each	\$ _____	/ea \$ _____
	SAP #6002183 RANGE, EXPANDO COOKING – ELECTRIC – 480 VOLT Same as 11A, except 480 volt, three phase. Approved Brand: Vulcan-Hart Model E12FP or other brands meeting bid specifications Brand Offered: _____ Model Offered: _____ Warranty Period: _____ Delivery (days ARO): _____		
TOTAL BID ITEM 11 (A – B inclusive)		\$ _____	

VENDOR NAME: _____
 BNG

The School Board of Broward County, Florida
CAFETERIA EQUIPMENT

SECTION 5, BID SUMMARY SHEET (Continued)

		<u>UNIT PRICE</u>	<u>TOTAL COST</u>
ITEM 12:	1 each		
	SAP #6001227		
	RANGE, EXPANDO COOKING – GAS FIRED (LP OR NATURAL)	\$ _____	/ea \$ _____
	<p>All purpose hot top range. Two open burners (35,000 BTU each). Front, exterior bottom including base channel, and fastening devices to be all stainless steel. Unit to be no greater than 17" wide, and a 27" cooking surface depth. Unit to have 27" deep cooking surface, total depth of unit not to exceed 38". 10" stainless steel low profile back guard. Front and cap, rear gas connection. Removable ring grates over each burner. Automatic Burner ignition. National Sanitation Foundation (NSF) and Canadian Standards Association (CSA) approved. Service manual, parts list, and wiring diagram must accompany each unit. Warranty: Two-year manufacturer's warranty, all parts and labor must be included in the unit price. INSTALLATION REQUIRED. Approved Brand: Garland Model M4S or other brands meeting bid specifications</p> <p>Brand Offered: _____ Model Offered: _____ Warranty Period: _____ Delivery (days ARO): _____</p>		

VENDOR NAME: _____
BNG

The School Board of Broward County, Florida
CAFETERIA EQUIPMENT

SECTION 5, BID SUMMARY SHEET (Continued)

		<u>UNIT PRICE</u>	<u>TOTAL COST</u>
ITEM 13:	<u>(TO BE AWARDED AS A GROUP)</u>		
A.	15 each	\$ _____	/ea \$ _____
	<p>SAP #6000133 KETTLE, STEAM JACKET – ELECTRIC – 208 VOLT Electrically heated completely automatic, self-contained 2/3 jacketed steam kettle. Capacity 40 gallons, solid one piece welded construction, outer sheathing air or fiber insulated. Overall height not to exceed 38". Stainless steel, type 304, inside finish to be polished. Exterior of kettle shall be finished to a #3 finish, ensuring maximum ease in cleaning and maintaining brilliant appearance. Type 316 stainless steel kettle liner. Kettle furnished with a sanitary tangent draw-off 2" diameter made of stainless steel complete with 1/8" removable <u>perforated strainer</u>. Reinforced bar rim for kettle stability. All controls shall be contained in a stainless steel enclosure within easy reach of operator. Controls include a thermostat, pilot light, pressure/vacuum gauge, contactor, water level sight glass, safety valve, and low water cut-off. Temperatures controlled from 150° to 270° F. and with a working steam pressure of up to 30 PSI. KW rating not to exceed 24 KW at 208 volt for this unit. Contactors and relay to be <u>mounted onto side of unit</u>. Complete with single hole deck mount faucet, 12" swing nozzle, 44" flex hose, spray valve, 6" wall bracket, and 1/2" male inlet, T&S model 5PR-1S12. Unit mounted on stainless steel legs. Unit to be NSF approved. Service manual, parts list, and wiring diagrams must accompany each delivered unit. <u>208 Volt, 3 phase.</u> Warranty: Three year manufacturer's warranty on all parts and labor must be included in the unit price. Include optional faucet and sprayer within the unit price. Unit Price must include uncrate, set in place & level, remove plastic, factory start-up, service manuals, schematic diagrams, and on-site demonstration for each delivered unit. Approved Brand: Groen Model EE40 or other brands meeting bid specifications Brand Offered: _____ Model Offered: _____ Warranty Period: _____ Delivery (days ARO): _____</p>		
B.	7 each	\$ _____	/ea \$ _____
	<p>SAP #6001232 KETTLE, STEAM JACKET – ELECTRIC – 480 VOLT Same as 13A, except 480 volt, three phase. Approved Brand: Groen Model EE40 or other brands meeting bid specifications Brand Offered: _____ Model Offered: _____ Warranty Period: _____ Delivery (days ARO): _____</p>		
TOTAL BID ITEM 13 (A – B inclusive)		\$ _____	

VENDOR NAME: _____
BNG

The School Board of Broward County, Florida
CAFETERIA EQUIPMENT

SECTION 5, BID SUMMARY SHEET (Continued)

		<u>UNIT PRICE</u>	<u>TOTAL COST</u>
ITEM 14:	4 each		
	SAP #6001230 KETTLE, STEAM JACKET – GAS FIRED – (LP OR NATURAL)	\$ _____	/ea \$ _____
	<p>Self-contained, completely automatic, 2/3-jacketed stainless steel kettle, operating from gas heated steam source contained within unit. Capacity 40 gallons, (W) approximately 43", and overall height not to exceed 41". Solid one piece welded construction. Type 316 stainless steel, inside finish to be polished, outside jacket stainless steel with stainless steel legs. Type 316 stainless steel kettle liner. Outer sheathing air or fiber insulated. Kettle furnished with a sanitary tangent draw-off 2" diameter made of stainless steel. Drain outlet shall be equipped with a removable 1/8" perforated stainless steel strainer. Reinforced bar rim for kettle stability. Temperatures controlled from 150° to 270° F. and with a working steam pressure of up to 30 PSI. All controls shall be contained in a stainless steel enclosure. Controls to include regulating thermostat, power-ON switch, Power-On indicator light, heat indicator light, low water indicator light, low water cut-off, pressure limit regulator, pressure gauge, a gas regulator valve and electronic ignition module, water level sight glass; with all operating controls front mounted. Complete with single hole deck mount faucet, 12" swing nozzle, 44" flex hose, spray valve, 6" wall bracket, and 1/2" male inlet, T & S model 5PR-1S12. Unit requires 1/2" NPT gas line and 115V electric supply to operate controls. Unit to be National Sanitation Foundation (NSF) and Canadian Standards Association (CSA) approved. Service manual, parts list, and wiring diagrams must accompany each delivered unit. Warranty: Three year manufacturer's warranty on all parts and labor must be included in the unit price. Include optional faucet and sprayer within the unit price. Approved Brand: Groen Model AH/1-40 or other brands meeting bid specifications</p>		

Brand Offered: _____
Model Offered: _____
Warranty Period: _____
Delivery (days ARO): _____

VENDOR NAME: _____
BNG

The School Board of Broward County, Florida
CAFETERIA EQUIPMENT

SECTION 5, BID SUMMARY SHEET

		<u>UNIT PRICE</u>	<u>TOTAL COST</u>
ITEM 15:	<u>(TO BE AWARDED AS A GROUP)</u>		
A.	40 each	\$ _____	/ea \$ _____
	<p>SAP #6000813</p> <p>REFRIGERATOR, TWO-DOOR, TWO SECTION</p> <p>Construction to be stainless steel exterior door, front, sides, & interior floor. Aluminum interior side walls and back. 20 gauge stainless steel door & door interior. Foamed-in-Place Polyurethane Insulation throughout. Front shroud to lift up for easy access to clean condenser coil. Refrigeration to be R-134a or R290 where available. Top mount refrigeration system. All-in-one SIMPLE controller with maximum of 4 parameters that is pre-programmed from the factory. Four sensors on front controller to include temp setting, manual defrost, and lockout. Exterior digital temperature display; automatic LED lighting with door switch. Durable removable snap-in magnetic gasket with 2 year warranty. Self-closing door with stay open feature. Lifetime guarantee on ergonomic door handle and cam-lift door hinges. Heavy duty cylinder or bolt locks with lifetime warranty. One door to have three (3) heavy-duty, epoxy coated or chrome shelves. One door complete with a minimum of 12 sets of universal tray/pan slides on 4" centers to accept bottom support 18" x 26" pans and 12" x 20" pans. All condensate water is disposed of automatically by the energy efficient, non-electric condensate evaporator. Condenser coil to be out of food zone. If expansion valve system Compressor to have high-pressure cut-off switch. If a capillary tube system then system must be oversized and balanced for quick recovery and pull down. Maintains temperatures of 33 degrees – 38 degrees. Inside storage capacity to be a minimum of 45.4 useable cubic feet. Heavy-duty 5" polyurethane plate casters, two with brakes. Size: Maximum height 84-1/4" on wheels, depth 36", length 52-53". 115V/60Hz/1 phase, amp draw not to exceed 11.0 with 9' or 10' Nema 5-15P cord/cap. NSF and UL approved. Warranty: Three year manufacturer's warranty, all parts and labor, five years for compressor must be included in the unit price. Warranty on compressor to be completely handled by service company for 5 years. Price to include uncrate, set in place, removal of cartons, installation of shelves and clips, pan slides and casters, plug in and make ready for use. Must ship from factory within 4 weeks of receipt of purchase order.</p> <p>Approved Brand: Victory Model RSA-2D-S1, TRUE STA2R-2S or other brands meeting bid specifications</p> <p>Brand Offered: _____</p> <p>Model Offered: _____</p> <p>Warranty Period: _____</p> <p>Delivery (days ARO): _____</p>		

VENDOR NAME: _____
BNG

The School Board of Broward County, Florida
CAFETERIA EQUIPMENT

SECTION 5, BID SUMMARY SHEET (Continued)

		<u>UNIT PRICE</u>	<u>TOTAL COST</u>
ITEM 15:	<u>(TO BE AWARDED AS A GROUP) – Continued</u>		
B.	25 each	\$ _____	/ea \$ _____
	<p>SAP #6000814 REFRIGERATOR, THREE-DOOR, THREE SECTION Construction to be stainless steel exterior door, front, sides, & interior floor. Aluminum interior side walls and back. 20 gauge stainless steel door & door interior liner. Front shroud to lift up for easy access to clean condenser coil. Refrigeration to be R-134a or R290 where available, foamed-in-place polyurethane insulation throughout. Top mount refrigeration system. All-in-one SIMPLE controller with maximum of 4 parameters that is pre-programmed from the factory. Four sensors on front controller to include temp. setting, manual defrost, and lockout. Exterior digital temperature display; automatic LED interior light with door switch. Durable removable magnetic snap-in gasket with 2 year warranty. Self-closing door with stay open feature. Lifetime guarantee on ergonomic door handle and cam-lift door hinges. Heavy duty cylinder or bolt locks with lifetime warranty. Two doors to have three (3) heavy-duty, epoxy coated or chrome shelves. One door complete with a minimum of 12 sets of universal tray/pan slides on 4" centers to accept bottom support 18" x 26" pans and 12" x 20" pans. All condensate water is disposed of automatically by the energy efficient, non-electric condensate evaporator. Condenser coil to be out of food zone. If expansion valve system, Compressor to have high-pressure cut-off switch. If a capillary tube system, then system must be oversized and balanced for quick recovery and pull down. Inside storage capacity to be a minimum of 45.4 useable cubic feet. Refrigerator to include the following options: heavy-duty 5" polyurethane plate casters, two with brakes, Maximum height 84-1/4" on casters, depth 36". Length 76-78". 115V/60Hz/1 phase, amp draw not to exceed 11.0 with 9' or 10' Nema 5-15P cord/cap. <u>NSF and UL approved.</u> Warranty: Three year manufacturer's warranty, five years for compressor must be included in the unit price. Warranty on compressor to be completely handled by service company for 5 years. Price to include uncrate, set in place, removal of plastic and cartons, installation of shelves and clips, plug in, and make ready for use. Must ship from factory within 4 weeks of receipt of purchase order. Approved Brands: Victory Model RSA-3D-S1, TRUE STA3R-3S or other brands meeting bid specifications</p> <p>Brand Offered: _____ Model Offered: _____ Warranty Period: _____ Delivery (days ARO): _____</p>		

TOTAL BID ITEM 15 (A – B inclusive)..... \$ _____

VENDOR NAME: _____
BNG

The School Board of Broward County, Florida
CAFETERIA EQUIPMENT

SECTION 5, BID SUMMARY SHEET (Continued)

		<u>UNIT PRICE</u>	<u>TOTAL COST</u>
ITEM 16:	<u>(TO BE AWARDED AS A GROUP)</u>		
A.	8 each	\$ _____	/ea \$ _____
	<p>SAP #6000069 CABINET, WARMING – ONE DOOR, ROLL THROUGH – 208 VOLT Cabinet insulation to be polyurethane foam. Construction to be stainless exterior and aluminum interior with stainless steel floor and s/s ramps. 20 gauge stainless steel door & door interior line. Front shroud to lift up for easy access to clean condenser coil. Foamed in place polyurethane insulation. Durable removable magnetic snap-in gasket with 2 year warranty. Self-closing door with stay open feature. Lifetime guarantee on ergonomic door handle and cam-lift door hinges. Heavy duty cylinder or bolt locks with lifetime warranty. To have interior LED lighting. Clear inside door openings to be minimum of 27-1/4" wide x 66-1/4" high allowing use of 27" wide x 29" deep x 64.5" high mobile racks. Rack offered must fit inside cabinet. Furnish with UL approved automatic 1500 watt heating system. 208/60/1. Include power indicator light, and digital thermometer. Unit is to be National Sanitary Foundation (NSF) and Underwriter's Laboratories (UL) approved. To include one fully welded rack of structural aluminum designed for fit in pass-through warmers. Rack must have 18 extruded angle ledge to hold bottom of pan with heavy duty 5" plate casters, 2 with brakes. Warranty: Three year manufacturer's warranty on all parts and labor must be included in the unit price. Price to include set up which includes uncrate, set in place, removal of plastic on unit and removal of cartons. Vendor responsible for leveling cabinet and caulking or sealing to floor where necessary. Wheels of rack must fit inside door with door closed. Installation of unit must be leveled and shimmed if necessary and sealed to the floor. Approved Brands: Victory Model HISA-1D-1-PT , True Model STA1HRT-1S-1S with Rack – Crescor Model 207-1818C or New Age Model 1335 or other brands meeting bid specifications Brand Offered: _____ Model Offered: _____ Rack Offered: _____ Warranty Period: _____ Delivery (days ARO): _____</p>		
B.	5 each	\$ _____	/ea \$ _____
	<p>SAP #6001109 CABINET, WARMING – ONE DOOR, ROLL THROUGH – 110 VOLT Same as 16A, except 110 volt, single phase. Approved Brands: Victory Model HISA-1D-1-PT, True Model ST A1HRT-1S-1S with Rack – Crescor Model 207-1818C or New Age Model 1335 or other brands meeting bid specifications Brand Offered: _____ Model Offered: _____ Rack Offered: _____ Warranty Period: _____ Delivery (days ARO): _____</p>		

VENDOR NAME: _____
BNG

The School Board of Broward County, Florida
CAFETERIA EQUIPMENT

SECTION 5, BID SUMMARY SHEET (Continued)

		<u>UNIT PRICE</u>	<u>TOTAL COST</u>
ITEM 16:	<u>(TO BE AWARDED AS A GROUP) - continued</u>		
C. 5 each	SAP #6 _____ CABINET, WARMING – TWO DOOR, ROLL THROUGH – 208 VOLT Cabinet insulation to be polyurethane foam. Construction to be stainless exterior and aluminum interior with stainless steel floor and s/s ramps. 20 gauge stainless steel door & door interior line. Front shroud to lift up for easy access to clean condenser coil. Foamed in place polyurethane insulation. Durable removable magnetic snap-in gasket with 2 year warranty. Self-closing door with stay open feature. Lifetime guarantee on ergonomic door handle and cam-lift door hinges. Heavy duty cylinder or bolt locks with lifetime warranty. To have interior LED lighting. Height not to exceed 84 1/4" to fit in wall cut-out. Clear inside door openings to be minimum of 27-1/4" wide x 66-1/4" high allowing use of 27" wide x 29" deep and 64.5" high mobile racks. To include 2 each fully welded racks of structural aluminum designed for fit in pass-through warmers. Rack must have 18 extruded angle ledge to hold bottom of pan with heavy duty 5" plate casters, 2 with brakes. Furnish with UL approved automatic 1500 watt heating system. 208/60/1. Include power indicator light and digital thermometer. Unit is to be National Sanitary Foundation (NSF) and Underwriter's Laboratories (UL) approved. Warranty: Three year manufacturer's warranty on all parts and labor must be included in the unit price. Price to include set up which includes uncrate, set in place, removal of plastic on unit and removal of cartons. Vendor responsible for leveling cabinet. Wheels of rack must fit inside door with door closed. Installation of unit must be leveled and shimmed if necessary and sealed to the floor. Approved Brands: Victory Model HISA-2D-1-PT , True Model STA2HRT-2S-2S with Rack – Crescor Model 207-1818C or New Age Model 1335 or other brands meeting bid specifications Brand Offered: _____ Model Offered: _____ Rack Offered: _____ Warranty Period: _____ Delivery (days ARO): _____	\$ _____	/ea \$ _____

TOTAL BID ITEM 16 (A – C inclusive)..... \$ _____

VENDOR NAME: _____
BNG

The School Board of Broward County, Florida
CAFETERIA EQUIPMENT

SECTION 5, BID SUMMARY SHEET (Continued)

		<u>UNIT PRICE</u>		<u>TOTAL COST</u>
ITEM 17:	20 each	SAP #6001334 REFRIGERATOR, TWO DOOR, ROLL-THROUGH WITH FULL DOORS	\$ _____	/ea \$ _____
		<p>Two-door roll-through refrigerator with full doors. Construction to be stainless steel exterior and aluminum interior with stainless steel floor and s/s ramps. 20 gauge stainless steel door & door interior liner. Foamed in place polyurethane insulation. Refrigeration to be R-134A or R290 where available. Durable removable magnetic snap-in gasket with 2 year warranty. Self-closing door with stay open feature. Lifetime guarantee on ergonomic door handle and cam-lift door hinges. Heavy duty cylinder or bolt locks with lifetime warranty. Each door opening accepts mobile storage rack 27" w x 29" d x 64.5" high. All-in-one SIMPLE controller with maximum of 4 parameters that are pre-programmed from the factory. Four sensors on front controller to include temp. setting, manual defrost and lockout. Exterior digital temperature display; automatic LED interior light with door switch. All condensate water is disposed of automatically by the energy efficient, non-electric condensate evaporator. No plumbing required. Power supply at top. Provide evaporator coil out of food zone. Condensing unit top mounted, air-cooled. If a capillary tube system, then system must be oversized and balanced for quick recovery and pull down. Maximum height of 84 - 1/4", depth 32"-37", and length 68"-69". Voltage to be 115/60/1 with 1/2 - 3/4 H.P. Compressor. Amp draw not to exceed 11.0 with 9' or 10' Nema 5-15P cord/cap. Upper end panels shall be removable allowing accessibility for service from front or sides. Unit is to be National Sanitary Foundation (NSF) and Underwriter's Laboratories (UL) listed. Warranty: Three year manufacturer's warranty on all parts and labor with warranty, five years on compressor must be included in the unit price. Warranty on compressor to include shipping and pick up of old compressor upon phone call to factory. Awardee must provide parts list, service manual, and schematics with each delivered unit. Ship with UL approved six-foot cord and plug set. Furnish with two roll-in racks all welded construction to fit refrigeration compartments. Set up includes uncrate, set in place, removal of cartons and removal of plastic on unit. Unit must be leveled and shimmed if necessary unit to be sealed to the floor. Bidder is responsible for leveling unit and caulk around perimeter to seal to floor. Approved Brands: REFRIGERATOR - Victory Model RISA-2D-S1-PT 7, TRUE STA2RRI-2S with RACKS – Crescor Model 207-1818C or New Age Model 1335 or other brands meeting bid specifications.</p> <p>Brand Offered: _____ Model Offered: _____ Rack Offered: _____ Warranty Period: _____ Delivery (days ARO): _____</p>		

VENDOR NAME: _____
BNG

The School Board of Broward County, Florida
CAFETERIA EQUIPMENT

SECTION 5, BID SUMMARY SHEET (Continued)

	<u>UNIT PRICE</u>	<u>TOTAL COST</u>
<p>ITEM 18: 5 each SAP #6000812 REFRIGERATOR, TWO DOOR, ROLL-IN WITH FULL DOORS Two-door roll-in refrigerator with full doors, stainless steel exterior and aluminum interior with stainless steel floor and s/s ramps. 20 gauge stainless steel door & door interior liner. Foamed in place polyurethane insulation. Refrigeration to be R-134a or R290 where available. Durable removable magnetic snap-in gasket with 2 year warranty. Self-closing door with stay open feature. Lifetime guarantee on ergonomic door handle and cam-lift door hinges. Heavy duty cylinder or bolt locks with lifetime warranty. Each door opening accepts mobile storage rack 27" w x 29" d x 64.5" high. All-in-one SIMPLE controller with maximum of 4 parameters that are pre-programmed from the factory. Four sensors on front controller to include temp. setting, manual defrost, and lockout. Exterior digital temperature display; automatic LED interior light with door switch. All condensate water is disposed of automatically by the energy efficient, non-electric condensate evaporator. Power supply at top. No plumbing required. Provide evaporator coil out of food zone. Condensing unit top mounted, air-cooled, expansion valve system or capillary tube system that is oversized and balanced for quick recovery and pull down. Maximum height of 84-1/4 " on casters, depth 32"-37", and length 68"-69". Voltage to be 115/60/1 with 1/2 - 3/4 h.p. compressor. Amp draw not to exceed 11.0 with 9' or 10' Nema 5-15P cord/cap. Upper end panels shall be removable allowing accessibility for service from front and sides. Unit is to be NSF and UL listed, and energy star rated. Warranty: Three manufacturer's year warranty on all parts and labor with five year on compressor must be included in the unit price. Warranty on compressor to include shipping and pick up of old compressor upon phone call to factory. Lifetime warranty against rust. <u>Awardee must provide parts list, service manual, and schematics with each delivered unit. Ship with UL approved six-foot cord and plug set. Furnish with two roll-in racks all welded construction to fit refrigeration compartments.</u> Set up includes uncrate, set in place, removal of cartons and removal of plastic on unit. Bidder is responsible for leveling unit and caulk around perimeter to seal to floor. Approved Brand: REFRIGERATOR – Victory Model RISA-2D-S1 or TRUE STA2RRT-2S-2S with RACKS – Crescor Model 207-1818C or New Age Model 1335 or other brands meeting bid specifications</p>	<p>\$ _____ /ea</p>	<p>\$ _____</p>

Brand Offered: _____
Model Offered: _____
Rack Offered: _____
Warranty Period: _____
Delivery (days ARO): _____

VENDOR NAME: _____
BNG

The School Board of Broward County, Florida
CAFETERIA EQUIPMENT

SECTION 5, BID SUMMARY SHEET (Continued)

		<u>UNIT PRICE</u>	<u>TOTAL COST</u>
ITEM 19:	20 each	\$ _____	/ea \$ _____
<p>SAP #6000810 FREEZER, REACH-IN, SELF-CONTAINED, THREE DOOR Freezer construction to be stainless steel exterior door, front, sides, & interior floor. Aluminum interior side walls and back. 20 gauge stainless steel door & door interior liner. Foamed-in-Place Polyurethane Insulation throughout. Front shroud to lift up for easy access to clean condenser coil. Maintains temperatures of -10 degrees. Refrigeration to be R-404a or R290 where available. Top mount refrigeration system. Capacity: minimum 69.0 cu. ft. Heavy duty 5" polyurethane plate casters, 2 with brakes. Each compartment shall have a chrome floor rack. Self-closing door with stay open feature. Lifetime guarantee on ergonomic door handle and cam-lift hinges. Heavy duty cylinder or bolt locks with lifetime warranty. All-in-one SIMPLE controller with maximum of 4 parameters that is pre-programmed from the factory. Four sensors on front controller to include temp. setting, manual defrost, and lockout. Exterior digital temperature display; automatic LED lighting with door switch. Durable removable magnetic snap-in gasket with 2 year warranty. Anti-condensate door perimeter heaters. Non-electric condensate evaporator top mounted that disposes of water automatically with pan of sufficient size to accommodate condensation. No plumbing required. Power supply at top. Provide evaporator coil out of food zone. Condensing unit top mounted. If a capillary tube system, then system must be oversized and balanced for quick recovery and pull down. Furnished with nine heavy-duty epoxy coated or chrome shelves, three per door to accommodate 18" x 26" sheet pans in each full door. Size: Maximum height 84-1/4" high, depth 36", length 76 - 78". Electrical: 208/-230/60/1, not to exceed 14.0 AMPS. Condensing unit 3/4 HP. Unit to be NSF and UL listed. Warranty: Three year manufacturer's warranty on all parts and labor plus warranty against condensation build up, five year warranty parts and labor on compressor must be included in the unit price. Warranty on compressor to include shipping and pick up of old compressor upon phone call to factory. Set-up will include installation of shelves and clips and installation of wheels. Uncrated and remove crate. Unit must be shipped with parts manual and schematics to each location. Approved Brand: Victory Model FSA-3D-S1, TRUE STA3F-3S or other brands meeting bid specifications</p>			
Brand Offered: _____ Model Offered: _____ Warranty Period: _____ Delivery (days ARO): _____			

VENDOR NAME: _____
BNG

The School Board of Broward County, Florida
CAFETERIA EQUIPMENT

SECTION 5, BID SUMMARY SHEET (Continued)

		<u>UNIT PRICE</u>	<u>TOTAL COST</u>	
ITEM 20:	45 each	SAP #6000811 FREEZER, REACH-IN, SELF-CONTAINED – TWO DOOR Freezer construction to be stainless steel exterior door, front, sides, & interior floor. Aluminum interior side walls and back. Foamed-in-Place Polyurethane Insulation throughout. Front shroud to lift up for easy access to clean condenser coil. Maintains temperatures of -10 degrees. Refrigeration to be R-404a or R290 where available. Top mount refrigeration system. Capacity: minimum 45.4 cu.ft.. Heavy duty 5" polyurethane plate casters, 2 with brakes. Each compartment shall have a chrome floor rack. Self-closing door with stay open feature. Lifetime guarantee on ergonomic door handle and cam-lift hinges. Heavy duty cylinder or bolt locks with lifetime warranty, all doors keyed alike. All-in-one SIMPLE controller with maximum of 4 parameters that is pre-programmed from the factory. Four sensors on front controller to include temp. setting, manual defrost, and lockout. Exterior digital temperature display; automatic LED lighting with door switch. Durable removable magnetic snap-in gasket with 2 year warranty. Breaker strips shall leave no exposed electrical heating elements and securely installed around entire perimeter of front frame and mullions of all door openings. Non-electric condensate evaporator top mounted that disposes of water automatically with pan of sufficient size to accommodate condensation. No plumbing required. Power supply at top. Provide evaporator coil out of food zone. Condensing unit op mounted. If a capillary tube system, then system must be oversized and balanced for quick recovery and pull down. Furnish with six heavy-duty epoxy coated or chrome shelves, to accommodate 18" x 26" pans, three per door. Size: Maximum height 84-1/4" high on wheels, depth 34-36", length 52 – 53". Electrical: 115/60/1, not to exceed 12 AMPS. 1/2 or 3/4 HP condensing unit. Unit to be NSF and UL listed. Warranty: Three year manufacturer's warranty on all parts and labor plus warranty against condensation build up, five year warranty parts and labor on compressor must be included in the unit price. Warranty on compressor to be completely handled by service company for 5 years. Set-up will include installation of shelves and clips and installation of wheels. Uncrate, set-in place, remove all cartons. Unit must be shipped with parts manual and schematics to each location. Approved Brands: Victory Model FSA-2D-S1, TRUE STA2F-2S or other brands meeting bid specifications	\$ _____	/ea \$ _____

Brand Offered: _____
Model Offered: _____
Warranty Period: _____
Delivery (days ARO): _____

VENDOR NAME: _____
BNG

The School Board of Broward County, Florida
CAFETERIA EQUIPMENT

SECTION 5, BID SUMMARY SHEET (Continued)

		<u>UNIT PRICE</u>	<u>TOTAL COST</u>	
<u>ITEM 21:</u>	10 each	SAP #6002185 WARMER, DISPLAY Adjustable display warmer with two-bulb reflectors and display base that accepts 12" x 20" steam table pans. Warmer to be 19-1/4" long x 13" wide x 28-1/4" high, with 6" wide bulb holder and 11-3/4" - 19-3/4" adjustable clearance between bottom of reflector and base. 120 volt, 500 watt with two 250W infrared bulbs included. Reflectors to be stainless steel, vented at the top, capable of holding one 250W bulb. On/off switch and six foot cord and plug included. <u>To be delivered completely assembled.</u> Manufacturer's standard warranty will apply. Approved Brands: American Permanent Ware Model DW-1A, Nemco Model 6000A-2 or other brands meeting bid specifications Brand Offered: _____ Model Offered: _____ Warranty Period: _____ Delivery (days ARO): _____	\$ _____	/ea \$ _____

		<u>UNIT PRICE</u>	<u>TOTAL COST</u>	
<u>ITEM 22:</u>	10 each	SAP #6000020 MERCHANDISER, GLASS DOOR Self-contained open front refrigeration system for self-serve salads and deli items designed for extreme high humidity environment. Steel construction with baked enamel finish inside and out. Approx. dimensions 52" x 30" x 72". Four-position lighted cantilever shelves. Expansion value system with heavy duty 1100 watt heated condensate pan, no drain required. CFC-free foamed-in-place urethane insulation. Timer controlled automatic defrost. Adjustable temperature controls. Minimum 3/4 HP compressor. Electrical: 115V/60 Hz/1 PH. Must have upgraded motor Maximum amp draw 24 for high humidity environment. Color: White. Warranty: Two year warranty parts and labor. Two year warranty on water leaking on floor from condensate pan. Five years against insulation failure or leaks in insulated area and five years on compressor. Holds product at FDA required temperatures below 41° Fahrenheit. Provide with locking casters. Bid includes uncrate, set-in place, carton removal and installation of casters. Warranty: Two manufacturer's year warranty, all parts and labor with five year parts/labor for compressor must be included in the unit price. Warranty on compressor to include shipping and pick up of old compressor upon phone call to factory. Price must include inside delivery and complete operational setup. Approved Brands: True Model GDM-23 or other brands meeting bid specifications Brand Offered: _____ Model Offered: _____ Warranty Period: _____ Delivery (days ARO): _____	\$ _____	/ea \$ _____

VENDOR NAME: _____
BNG

The School Board of Broward County, Florida
CAFETERIA EQUIPMENT

SECTION 5, BID SUMMARY SHEET (Continued)

<u>ITEM 23:</u>	<u>(TO BE AWARDED AS A GROUP)</u>	<u>UNIT PRICE</u>	<u>TOTAL COST</u>
	SHELVING, ADJUSTABLE FOR WALK-IN COOLERS		
	Removable open grid shelf mats are injection-molded polypropylene with built in Microban antimicrobial protection. With epoxy coated steel frames and posts. Weight Capacity for evenly distributed loads is 800 lbs. per shelf for lengths 36" to 48".		
	<u>Individual shelf price to include:</u> Inside delivery, uncrating, removal of packaging materials, four tier assembly and INSTALLATION REQUIRED inside walk-in cooler/freezer, and demonstration of features to Food Service managers. First shelf to be 6" AFF and remaining shelves to be spaced equally. Installation of shelves and posts included in bid price. Manufacturer's standard warranty will apply.		
	Approved Brands: InterMetro "MetroMaxQ", Amco Plastic Plus or other brands meeting bid specifications.		
A.	4 each SAP #6001239, SHELF , 18" Wide X 24" Long (QG)	\$ _____	/ea \$ _____
B.	12 each SAP #6001238, SHELF , 18" Wide X 30" Long (QG)	\$ _____	/ea \$ _____
C.	48 each SAP #6001234, SHELF , 18" Wide X 36" Long (QG)	\$ _____	/ea \$ _____
D.	36 each SAP #6000138, SHELF , 18" Wide X 42" Long (QG)	\$ _____	/ea \$ _____
E.	100 each SAP #6000139, SHELF , 18" Wide X 48" Long (QG)	\$ _____	/ea \$ _____
F.	4 each SAP #6001240, SHELF , 18" Wide X 54" Long (QG)	\$ _____	/ea \$ _____
G.	4 each SAP #6001236, SHELF , 18" Wide X 60" Long (QG)	\$ _____	/ea \$ _____
H.	4 each SAP #6001241, SHELF , 24" Wide X 24" Long (QG)	\$ _____	/ea \$ _____
I.	12 each SAP #6001242, SHELF , 24" Wide X 30" Long (QG)	\$ _____	/ea \$ _____
J.	48 each SAP #6001243, SHELF , 24" Wide X 36" Long (QG)	\$ _____	/ea \$ _____
K.	8 each SAP #6001244, SHELF , 24" Wide X 42" Long (QG)	\$ _____	/ea \$ _____
L.	48 each SAP #6001245, SHELF , 24" Wide X 48" Long (QG)	\$ _____	/ea \$ _____
M.	4 each SAP #6001246, SHELF , 24" Wide X 54" Long (QG)	\$ _____	/ea \$ _____
N.	4 each SAP #6001247, SHELF , 24" Wide X 60" Long (QG)	\$ _____	/ea \$ _____
O.	100 each SAP #6001237, POST , 63" or 64" High (QPE)	\$ _____	/ea \$ _____
P.	100 each SAP #6000140, POST , 72" or 74" High (QPE)	\$ _____	/ea \$ _____

Brand Offered: _____
Warranty Period: _____
Delivery (days ARO): _____

TOTAL BID ITEM 23 (A – P inclusive) \$ _____

VENDOR NAME: _____
BNG

The School Board of Broward County, Florida
CAFETERIA EQUIPMENT

SECTION 5, BID SUMMARY SHEET (Continued)

		<u>UNIT PRICE</u>	<u>TOTAL COST</u>
ITEM 24: (TO BE AWARDED AS A GROUP)			
A.	10 each	SAP #6000071 WARMER, COOKER – 7 QUART Seven Quart round cooker (crock pot) for heating soups. Type 430 stainless steel exterior, 24 gauge aluminum deep drawn well and heavy duty thermostat. Element band heating for even distribution. 110-120V, minimum 500 watts with 3 prong grounded plug. <u>Unit price must include aluminum insert, lid and ladle.</u> Warranty: One year all parts and labor must be included in the unit price. Approved Brand: Nemco Model 6102-ICL, Vollrath Model 72018 or other brands meeting bid specifications	\$ _____ /ea \$ _____
		Brand Offered: _____ Model Offered: _____ Warranty Period: _____ Delivery (days ARO): _____	
B.	10 each	SAP #6000072 WARMER, COOKER – 11 QUART Eleven Quart round cooker (crock pot) for heating soups. Type 430 stainless steel exterior, 24 gauge aluminum deep drawn well and heavy duty thermostat. Element band heating for even distribution. 110-120V, minimum 500 watts with 3 prong grounded plug. <u>Unit price must include aluminum insert, lid and ladle.</u> Warranty: One year all parts and labor must be included in the unit price. Approved Brand: Nemco Model 6103-ICL, Vollrath Model 72009 or other brands meeting bid specifications	\$ _____ /ea \$ _____
		Brand Offered: _____ Model Offered: _____ Warranty Period: _____ Delivery (days ARO): _____	
TOTAL BID ITEM 24 (A – B inclusive).....			\$ _____

VENDOR NAME: _____
BNG

The School Board of Broward County, Florida
CAFETERIA EQUIPMENT

SECTION 5, BID SUMMARY SHEET (Continued)

		<u>UNIT PRICE</u>	<u>TOTAL COST</u>
<u>ITEM 25:</u>	3 each SAP #6001076 MERCHANDISER, REFRIGERATED VERTICAL OPEN Self-contained open front refrigeration system for self-serve salads and deli items designed for high humidity environment without a floor drain. Steel construction with baked enamel finish inside and out. Approx. dimensions 52" x 30" x 72". Four-position lighted cantilever shelves. Expansion valve system with heavy duty 1100 watt heated condensate pan, no drain required. CFC-free foamed-in-place urethane insulation. Timer controlled automatic defrost. To include high humidity condensate pan – to be 120 v., and amp draw not to exceed 10. Adjustable temperature controls. Minimum 3/4 HP compressor. Electrical: 115V/60 Hz/1 PH. Maximum amp draw 24. Includes optional wrap around bumper and night cover. Color: White. Warranty: Two year warranty parts and labor. Five years against insulation failure or leaks in insulated area and five years on compressor. Holds product at FDA required temperatures below 41° Fahrenheit. Provide with locking casters. Bid includes uncrate, set-in place, carton removal and installation of casters. Warranty: Two manufacturer’s year warranty, all parts and labor with five year parts/labor for compressor must be included in the unit price. Warranty on compressor to include shipping and pick up of old compressor upon phone call to factory. Price must include inside delivery and complete operational setup. Approved Brands: Hussman GSVM-5272 & Part #035S098, True Model TAC-48-LD with part #80944 or other brands meeting bid specifications Brand Offered: _____ Model Offered: _____ Warranty Period: _____ Delivery (days ARO): _____	\$ _____	/ea \$ _____

VENDOR NAME: _____
BNG

The School Board of Broward County, Florida
CAFETERIA EQUIPMENT

SECTION 5, BID SUMMARY SHEET (Continued)

		<u>UNIT PRICE</u>	<u>TOTAL COST</u>
<u>ITEM 26:</u>	5 each SAP #6002186 DRAWER, WARMER Exterior of drawer made of 20 gauge non-magnetic (corrosion resistant) stainless steel with (1) set of removable 16 gauge stainless drawer rail supports per drawer. Each cabinet is controlled by (1) On/Off adjustable thermostat with a range of 60° to 200°F and includes one holding temperature gauge to monitor inside air temperature. Analog temperature control. Each drawer includes (1) 12" x 20" x 6" stainless steel pan. The drawer assembly is easily adapted to accept an oversized 15" x 20" x 5" pan for greater capacity. Electrical: 120V/60 Hz/1 PH, 5 – 10 amps, 600 to 1200 Watts. Installed cord/cap: Nema 5-15P. Exterior size: 24-3/8"W x 24-5/8"L x 26-1/8"H. Warranty: Two manufacturer's year warranty all parts and labor to be included in unit price. Bid includes uncrate, set-in place and removal of cartons. Approved Brands: Alto Shaam Model 500-2D or other brands meeting bid specifications Brand Offered: _____ Model Offered: _____ Warranty Period: _____ Delivery (days ARO): _____	\$ _____	/ea \$ _____

VENDOR NAME: _____
BNG

The School Board of Broward County, Florida
CAFETERIA EQUIPMENT

SECTION 5, BID SUMMARY SHEET (Continued)

		<u>UNIT PRICE</u>	<u>TOTAL COST</u>
ITEM 27:	<u>(TO BE AWARDED AS A GROUP)</u>		
A. 3 each	<p>SAP #6000122 OVEN, DOUBLE CONVECTION – STACK, GAS FIRED (LP/NATURAL) Unit to consist of two oven sections stacked operating separately and independently. Stainless steel front, top, and sides. Simultaneous doors with dual pane thermal glass windows encased in stainless steel door frame with two cool touch handles. Oven doors mounted on 5/8" steel pin and 5/8" lubricated bearings, with three recessed bolts under each door. Doors to include stainless steel door gaskets. Door linkage to be triple hinged. Oven to have five year limited warranty on doors. Oven liner shall be double-sided chip-proof porcelain enameled steel inside and out with coved corners. Unit to have 6" adjustable stainless steel legs with all fastening devices stainless steel. Fully welded angle iron frame construction. Each section to be furnished with six chrome plated steel, heavy wire removable racks. Door, when opened, will automatically cut off fan. Also, to have switch to operate blower with door open for quick cool-down. Unit to have 60 minute batch timer, or electronic timer, and oven light switch and "oven ready" indicator light. To be supplied with solid state <u>manual</u> control with two speed fan. Insulated with 1" high temperature solid mineral fiberboard or other non-sag material. Main burner(s) ignition shall be achieved by a pilot burner operating through an electronic proven pilot spark ignition control system. <u>Each section</u> to have easily removable burners with a rated total input minimum of 60,000 BTU's. Two speed 1/2 - 3/4 h.p. motor with thermal overload protection. Porcelain enameled modular control panel shall be supplied with a 100% electrical disconnect and shall slide forward or be completely removable for servicing. Controls and fan motor to operate on 115V AC single phase, 8 amps. All units National Sanitation Foundation (NSF) approved. Service manual, parts list and wiring diagrams must accompany each unit. Minimum interior dimensions: 27" w. x 27 1/8" d. x 29 1/4" h. Warranty: Two year manufacturer's warranty all parts and labor must be included in the unit price. Unit Price must include installation, service manuals, schematic diagrams and on-site demonstration for each delivered unit. Approved Brand: Blodgett Model DFG-100-ES, Garland MCO-GS-20, Vulcan SG44. Brand Offered: _____ Model Offered: _____ Warranty Period: _____ Delivery (days ARO): _____</p>	\$ _____	/ea \$ _____

VENDOR NAME: _____
BNG

The School Board of Broward County, Florida
CAFETERIA EQUIPMENT

SECTION 5, BID SUMMARY SHEET (Continued)

		<u>UNIT PRICE</u>	<u>TOTAL COST</u>
ITEM 27:	<u>(TO BE AWARDED AS A GROUP) - Continued</u>		
B.	4 each	\$ _____	/ea \$ _____
	<p>SAP #6001224 OVEN, CONVECTION – SINGLE SECTION, GAS FIRED – NATURAL OR LP Single unit with dependent (simultaneous) doors. Stainless steel front, top, and sides. Simultaneous doors with dual pane thermal glass windows encased in stainless steel door frame with cool touch handles. <u>Handles must be cool to the touch when oven is on.</u> Adjustable legs and all fastening devices to be stainless steel. Oven doors independently mounted on 5/8" pin, and 5/8" lubricated bearings, with three recessed bolts under each door. Door linkage to be triple-mounted. Oven to have five year warranty on complete door assembly. Oven liner shall be double sided porcelain enameled steel inside and out with coved corners. Doors, when open, will automatically cut off fan. Also to have switch to operate blower with door open for quick cool-down. Units to have 60 minute batch timer and oven light switch. To be supplied with solid state <u>manual</u> control with two speed fan. Insulated with 1" high-temperature solid mineral fiberboard or other non-sag material. Each oven to have indicator light to indicate when burners are operating. Main burner ignition shall be achieved by a pilot burner operating through an electronic proven pilot spark ignition control system. Each section shall have two easily removable dual tube burners with a rotated total input minimum of 60,000 BTU's. Two speed-1/2 - 3/4 h.p. motor with thermal overload protection. Porcelain enameled modular control panel shall be supplied with a 100% electrical disconnect and shall slide forward or be completely removable for servicing. Controls and fan motor to operate on 115V, AC single phase. All units to be Canadian Standards Association (CSA) and National Sanitation Foundation (NSF) approved. Furnish six chrome, heavy wire racks (removable) with unit. Service manual, parts list and wiring diagrams must accompany each unit. Minimum interior dimensions: 27" w x 27 1/8" d x 29 1/4" h. Warranty: Two year manufacturer's warranty, all parts and labor must be included in the unit price. Unit Price must include inside delivery, set in place, level, remove packing materials, service manuals, schematic diagrams, factory start up, and on-site demonstration. Approved Brands: Blodgett Model DFG-100-ES, Garland MCO-GS-10, Vulcan SG4. Brand Offered: _____ Model Offered: _____ Warranty Period: _____ Delivery (days ARO): _____</p>		
TOTAL BID ITEM 27 (A – B inclusive)			\$ _____

VENDOR NAME: _____
BNG

The School Board of Broward County, Florida
CAFETERIA EQUIPMENT

SECTION 5, BID SUMMARY SHEET (Continued)

		<u>UNIT PRICE</u>	<u>TOTAL COST</u>
<u>ITEM 28:</u>	<u>(TO BE AWARDED AS A GROUP)</u>		
A. 12 each	SAP #6000123 OVEN, CONVECTION – SINGLE SECTION, ELECTRIC FIRED Single unit with dependent simultaneous doors. Stainless steel front, sides, and top. <u>Handles must be cool to the touch when oven is on.</u> Adjustable legs and all fastening devices to be stainless steel. Oven doors independently mounted on 5/8" pin, and 5/8" lubricated bearings, with three recessed bolts under each door. Door linkage to be triple-mounted. Porcelain enamel oven interior with coved corners. Dual pane thermal windows encased in stainless steel door frame. 5 Year limited door warranty. Doors, when open, will automatically cut off fan. Also to have switch to operate blower with door open for quick cool-down. Fully welded angle iron frame construction. Units to have 60 minute batch timer and oven light switch. To be supplied with solid state <u>manual</u> control with two speed fan. Insulated with 1" high-temperature solid mineral fiberboard or other non-sag material. Dual pane thermal window encased in stainless steel door frame. Each oven to have indicator light to indicate when burners are operating. Each section to be furnished with six chrome plated steel, heavy wire removable racks and crumb tray. Standard depth baking compartment that accepts five (5) 18" x 26" sheet pans in left to right positions. Each section shall have three tubular heaters, one or three with a combined heater rating of 11.0 KWH. Electric 208V. Single or three phase. Air in baking chamber distributed by inlet blower wheel powered by a two speed, ½ - ¾" h.p. motor with thermal overload protection. Nominal amperes per line not to exceed 32 to fit on existing 40 amp breaker. Control area cooling fan. Porcelain enameled modular control panel shall be supplied with a 100% electrical disconnect and shall slide forward or be completely removable for servicing. Controls and fan motor to operate on 115V, AC single phase. All units to be Underwriter's Laboratories (UL) approved and National Sanitation Foundation (NSF) approved. Furnish six chrome, heavy wire racks (removable) with unit. Service manual, parts list and wiring diagrams must accompany each unit. Warranty: Two year manufacturer's warranty all parts and labor must be included in the unit price. <u>Unit Price must include uncrate, set in place & level, remove plastic, provide service manuals, schematic diagrams and on-site demonstration for each delivered unit.</u> Approved Brand: Blodgett Model Mark V-100, Garland ES-10-S MCO Brand Offered: _____ Model Offered: _____ Warranty Period: _____ Delivery (days ARO): _____	\$ _____	/ea \$ _____

VENDOR NAME: _____
 BNG

The School Board of Broward County, Florida
CAFETERIA EQUIPMENT

SECTION 5, BID SUMMARY SHEET (Continued)

		<u>UNIT PRICE</u>	<u>TOTAL COST</u>
ITEM 28:	<u>(TO BE AWARDED AS A GROUP) - Continued</u>		
B.	25 each	\$ _____	/ea \$ _____
	SAP #6001221		
	OVEN, CONVECTION – SINGLE SECTION, ELECTRIC FIRED		
	Same as Item 28A, except 480Volt, three phase.		
	Approved Brand: Blodgett Model Mark V, Garland MCO ES-10-S or other brands meeting bid specifications		
	Brand Offered: _____		
	Model Offered: _____		
	Warranty Period: _____		
	Delivery (days ARO): _____		

VENDOR NAME: _____
BNG

The School Board of Broward County, Florida
CAFETERIA EQUIPMENT

SECTION 5, BID SUMMARY SHEET (Continued)

		<u>UNIT PRICE</u>	<u>TOTAL COST</u>
ITEM 28:	<u>(TO BE AWARDED AS A GROUP) - Continued</u>		
C.	4 each	\$ _____	/ea \$ _____
	<p>SAP #6001222</p> <p>OVEN, CONVECTION DOUBLE STACK - ELECTRIC</p> <p>Electric, 208V, three phase, 12 K.W. unit to consist of two oven sections stacked operating separately and independently. Dependent doors, stainless steel inside and out. Stainless steel front, sides, and top. 5 Year limited door warranty. Doors to have a handle mounted on left hand door which shall operate both doors simultaneously to 140 degrees. Doors to include stainless steel door gaskets. Dual pane thermal windows encased in stainless steel door frame. 5 Year limited door warranty. Oven door independently mounted on 5/8" pin and 5/8" lubricated bearings with three recessed bolts under each door. Door linkage to be triple-mounted. Double sided coved porcelain liner interior and exterior to prevent rusting. Unit to have 6" adjustable stainless steel legs with all fastening devices to be stainless steel. Each section to be furnished with six chrome plated steel, heavy wire removable racks and crumb tray. Standard depth baking compartment that accepts five (5) 18" x 26" sheet pans in left to right positions. Door, when opened, will automatically cut off fan. To be supplied with solid state <u>manual</u> control with two speed fan. Also, to have switch to operate blower with door open for quick cool-down. Each section shall be equipped with three tubular heaters, one or three phase with a combined heater rating of 10 KWH control area cooling fan. Unit to have 60 minute batch timer, or electronic timer, and oven light switch and "oven ready" indicator light. Solid state infinite setting with temperature control. Insulation on top, back and sides to have 1" high temperature solid mineral fiber board insulation or other non-sag material, 1/2 - 3/4 h.p., 2 speed motor with thermal overload protection. Nominal amperes per line not to exceed 32 to fit on existing 40 amp breaker. All units to be National Sanitation Foundation (NSF) and Underwriter's Laboratories (UL) approved. <u>Unit Price must include uncrate, set in place & level, remove plastic, provide service manuals, schematic diagrams and on-site demonstration for each delivered unit.</u> Warranty: Two year manufacturer's warranty, all parts and labor must be included in the unit price.</p> <p>Approved Brand: Blodgett Model Mark V-100, Garland MCO-ES-20-S or other brands meeting bid specifications</p> <p>Brand Offered: _____</p> <p>Model Offered: _____</p> <p>Warranty Period: _____</p> <p>Delivery (days ARO): _____</p>		

VENDOR NAME: _____
BNG

The School Board of Broward County, Florida
CAFETERIA EQUIPMENT

SECTION 5, BID SUMMARY SHEET (Continued)

		<u>UNIT PRICE</u>	<u>TOTAL COST</u>
ITEM 28: (TO BE AWARDED AS A GROUP) - Continued			
D.	3 each	SAP #6001223 OVEN, CONVECTION DOUBLE STACK - ELECTRIC Same as Item 27C, except 480Volt, three phase. Approved Brand: Blodgett Model Mark V-100, Garland MCO-ES-20-S, or other brands meeting bid specifications	\$ _____ /ea \$ _____
		Brand Offered: _____	
		Model Offered: _____	
		Warranty Period: _____	
		Delivery (days ARO): _____	
E.	8 each	SAP #6000131 BOILERLESS ONE-COMPARTMENT STEAMER Steamer cavity to be constructed of reinforced 14 gauge 304 stainless steel. Stainless steel support. Stand with flanged feet. No moving parts inside cooking chamber. Stem to be produced inside. Cooking cavity with no heating element exposed to water. Easily connects to water and drain Line. Unit to include low water, high water, overtemp warning lights and auto shut off feature. No water filtration or treatment required. No scheduled de-liming or maintenance. Holds 6 each full size 12 x 20 x 4" steamtable pans. Standard digital or manual controls with independent timer. 3/4" water connection in back of unit for automatic water fill. Water drain in front. U.L. and NSF approved. Energy Star qualified. AMP draw not to exceed 42.0 at 208v, 3 phase. Left hand hinge doors. <u>Bid price to include stainless steel stand with pan slides and installation of steamer on stand, leveling of unit.</u> Warranty: Two year warranty, all parts and labor must be included in the unit price. Approved Brands: Accutemp E68023E150SGL or other brands meeting specifications.	\$ _____ /ea \$ _____
		Brand Offered: _____	
		Model Offered: _____	
		Warranty Period: _____	
		Delivery (days ARO): _____	

VENDOR NAME: _____
BNG

The School Board of Broward County, Florida
CAFETERIA EQUIPMENT

SECTION 5, BID SUMMARY SHEET (Continued)

		<u>UNIT PRICE</u>	<u>TOTAL COST</u>
ITEM 28:	<u>(TO BE AWARDED AS A GROUP) - Continued</u>		
F.	40 each		
	SAP#6000134		
	CONVECTION STEAMER, TWO COMPARTMENT ELECTRIC STEAM GENERATOR. 6 PAN CAPACITY	\$ _____	/ea \$ _____
	<p>Stainless steel pressure-less steamer with two twin atmospheric electric independent. Steam generators rated at a minimum of 9.0 KW each complete with electric low water cut-off. Heat up time to be minimum of ten minutes or less from a cold start. Unit shall allow operator to delime both steam generators through access port in each cavity without tools or service call from service agency.</p> <p>Cavities and cabinet base stainless steel construction. Doors to be stainless steel, insulated, and provided with one-piece replaceable seal. Doors to have hidden magnetic door switch cutting power to blower and reducing power to generator when door is opened. 60 minute mechanical timer. Unit to include "Ready" or equivalent indicator light. Complete with automatic blow down when unit is turned off. Capacity for six 12" x 20" x 2-1/2" deep pans. Four stainless steel legs with level adjustment. Controls easily accessible from front or sides. Dual cold water connection provided so that steam generator is on a separate line from condenser.</p> <p>National Sanitation Foundation (NSF) and Underwriter's Laboratories (UL) approved Note to installers: Plumbing requirements: Unit requires two 3/4" or 3/8" IPS cold water supply lines, 1-1/2" O.D. free venting drain. A second cold water connection is also provided for spray condenser.</p> <p>Filter: Complete with Everpure Filter Model EV9797-22 Kleen Steam II Twin Filter System. Provide 2 ea. 4FC5 (EV9693-21) filters installed in system in lieu of 2 each EV9618-16 that comes standard with the system.</p> <p>Electrical requirements: Unit requires 208V, single phase three wire or three phase. Unit must fit on existing 60 amp breaker in schools. Warranty: Two year warranty, all parts and labor must be included in the unit price. Unit price must include uncrating, set-in place, Remove cartons, level, factory start up. Service manuals, parts lists and wiring diagrams must accompany each delivered unit.</p> <p>Approved Brands: Groen Hyper Steam Model HY-6E or other brands meeting bid specifications.</p> <p>Brand Offered: _____</p> <p>Model Offered: _____</p> <p>Warranty Period: _____</p> <p>Delivery (days ARO): _____</p>		

VENDOR NAME: _____
BNG

The School Board of Broward County, Florida
CAFETERIA EQUIPMENT

SECTION 5, BID SUMMARY SHEET (Continued)

		<u>UNIT PRICE</u>	<u>TOTAL COST</u>
ITEM 28:			
G.	5 each		
	SAP #6000135		
	STEAMER, CONVECTION, TWO COMPARTMENT – GAS FIRED, NATURAL OR LP	\$ _____	/ea \$ _____
	<p>Stainless steel pressure-less steamer with two twin atmospheric independent gas steam generators rated at a minimum of 35,000 BTU's each at 75% efficiency or minimum of 45,000 BTU's at 65% efficiency. Standing pilot light with electronic spark ignition. Heat up time shall be a minimum of ten minutes from a cold start. Unit to have low water cut-off. Unit shall allow operator to de-lime both steam generators through access port in each cavity without tools or service call from service agency.</p> <p>Cavities and cabinet base minimum 18 gauge 304 S/S stainless steel construction. Doors to be stainless steel, insulated, and provided with one-piece replaceable seal or gasket. Door to have hidden magnetic door switch cutting power to blower and reducing power to generator when door is opened. Unit to include "Ready" or equivalent indicator light. 60 minute mechanical timer. Complete with automatic blow down when unit is turned off. Capacity for six 12" x 20" x 2-1/2" deep pans. Four stainless steel legs with level adjustment. Controls easily accessible by pullout drawer or lift-off panel. Dual cold water connection necessary so that steam generators are on a separate line from condenser. NSF or CSA approved.</p> <p>UNIT REQUIRES TWO 3/4" OR 3/8" IPS COLD WATER SUPPLY LINES, 1-1/2" OD FREE VENTING AND ELECTRIC SERVICE NOT TO EXCEED 115 V., SINGLE PHASE, 4 AMP.</p> <p>FILTER: Complete with Everpure Filter Model EV9797-22 Kleen Steam II Twin Filter System. Provide 2 ea. 4FC5 (EV9693-21) filters installed in system in lieu of 2 each EV9618-16 that comes standard with the system.</p> <p><u>GAS REQUIREMENTS:</u> UNIT REQUIRES NATURAL OR LP VIA 1/2" NPT PIPE OR APPROVED EQUIVALENT.</p> <p>UNIT REQUIRES 115V, SINGLE PHASE, FOUR AMP ELECTRIC SERVICE.</p> <p>Warranty: Two manufacturer's year warranty, all parts and labor must be included in the unit price. Unit price must include uncrating, set-in place, level unit and factory start-up. Service manuals, parts lists and wiring diagrams must accompany each delivered unit.</p> <p>Approved Brands: Groen Hyper Steam Model HY-6G or other brands meeting bid specifications</p> <p>Brand Offered: _____</p> <p>Model Offered: _____</p> <p>Warranty Period: _____</p> <p>Delivery (days ARO): _____</p>		
	TOTAL BID ITEM 28 (A – G inclusive)		\$ _____

VENDOR NAME: _____
BNG

The School Board of Broward County, Florida
CAFETERIA EQUIPMENT

SECTION 5, BID SUMMARY SHEET (Continued)

		<u>UNIT PRICE</u>	<u>TOTAL COST</u>
ITEM 29:	<u>(TO BE AWARDED AS A GROUP)</u>		
A.	12 each	\$ _____	/ea \$ _____
	<p>SAP #6000097 CART, FOOD – OUTDOOR, SECONDARY 74-1/4" long x 31-3/4" wide x 94" high, weight 240 pounds. Polyethylene with two insulated compartments below for storage and three four open compartments above to hold 4 full size pans 6" deep. To include cash drawer, removable umbrella 72" diameter, and a display panel to display menu. Work counter height is 36" with a see-through panel in front to help merchandise food. Casters are 8", four swivel and four brakes. Unit must be able to roll easily over concrete sidewalks. Manufacturer's standard warranty will apply. Colors: Black, red, green, or gray. Price must include inside delivery and complete operational setup. Approved Brand: Cambro "Camcruiser" Model CVC724 or other brands meeting bid specifications</p> <p>Brand Offered: _____ Model Offered: _____ Colors Offered: _____ Warranty Period: _____ Delivery (days ARO): _____</p>		
B.	15 each	\$ _____	/ea \$ _____
	<p>SAP #6000098 STAND, CASHIER FOR OUTDOOR FOOD CART 27-3/4"wide x 27-3/4"deep x 39" high, with five inch heavy duty casters (two fixed and two swivel with brakes), seamless one-piece polyethylene construction to include right and left tray rail. Manufacturer's standard warranty will apply. <u>Color:</u> Black. Price must include inside delivery and complete operational setup. Approved Brands: Cambro Model ES28RL or other brands meeting bid specifications</p> <p>Brand Offered: _____ Model Offered: _____ Colors Offered: _____ Warranty Period: _____ Delivery (days ARO): _____</p>		

VENDOR NAME: _____
BNG

The School Board of Broward County, Florida
CAFETERIA EQUIPMENT

SECTION 5, BID SUMMARY SHEET (Continued)

		<u>UNIT PRICE</u>	<u>TOTAL COST</u>	
ITEM 29: (TO BE AWARDED AS A GROUP) - Continued				
C.	3 each	SAP #6000114 CAMCART FOR FOOD PAN – CAPACITY 12 OR 16 PANS Enclosed seamless, one-piece, double-wall insulated cart. Polyethylene exterior. Polyurethane foam insulation. Heavy-duty design with two separate cavities for cold and hot foods. Recessed corrosion-free stainless steel hardware with rubber gasket for air tight closing to seal in heat. 5" - 6" diameter casters. Exterior dimensions with casters to be approximately 28-1/2" W x 32-1/4" D x 45-1/2" H. Capacity for 12 each 12-3/4" x 20-7/8" x 4" deep or 16 each 12-3/4" x 20-7/8" x 2-1/2" deep food pans. Manufacturer's standard warranty will apply. Approved Brand: Cambro Model UPC1200 or other brands meeting bid specifications Brand Offered: _____ Model Offered: _____ Warranty Period: _____ Delivery (days ARO): _____	\$ _____ /ea	\$ _____
D.	3 each	SAP #6000115 CAMCART FOR FOOD PAN – CAPACITY 13 PANS Enclosed seamless, one-piece, double-wall insulated cart. Polyethylene exterior. Polyurethane foam insulation. Heavy-duty design with one compartment. Recessed corrosion-free stainless steel hardware with rubber gasket for air tight closing to seal in heat. 5" - 6" diameter casters. Exterior dimensions to be approximately 32" L x 21-1/2" W x 37-1/2" H. Capacity for 13 each 18" x 26" sheet pans. 13 Tray supports on 1-3/4" centers. Manufacturer's standard warranty will apply. Approved brand: Cambro Model 1826LTC or other brands meeting bid specifications Brand Offered: _____ Model Offered: _____ Warranty Period: _____ Delivery (days ARO): _____	\$ _____ /ea	\$ _____

VENDOR NAME: _____
BNG

The School Board of Broward County, Florida
CAFETERIA EQUIPMENT

SECTION 5, BID SUMMARY SHEET (Continued)

		<u>UNIT PRICE</u>	<u>TOTAL COST</u>
ITEM 29:	<u>(TO BE AWARDED AS A GROUP) - Continued</u>		
E.	20 each	\$ _____	/ea \$ _____
	<p>SAP # _____</p> <p>CART, CAMKIOSK, WITH UMBRELLA 85 1/8" long X 33-1/2" wide x 70 1/2" high, Polyethylene exterior with foam insulation that will not crack, chip, bubble, or break. Two insulated food storage cabinets to maintain hot food hot, cold food cold. Insulated compartments below for storage and four pan wells at top with work space. To include removable umbrella 72" diameter, lockable cash drawer, and menu display. Work counter height is 36". Casters are 6", two swivel, and two with brakes. Unit must be able to roll easily over concrete sidewalks. Manufacturer's standard warranty will apply. Standard colors: Green, black, gray or equivalent. Accessories to include 2 each 1/2 size camchillers. Cambro model CP1210 or Equivalent and 1 each well cover. Cambro model WCR120. Price must include inside delivery and complete operational setup. Approved Brand: Cambro "Camkiosk" Model KVC854C or other brands meeting bid specifications Brand Offered: _____ Model Offered: _____ Warranty Period: _____ Delivery (days ARO): _____</p>		
F.	3 each	\$ _____	/ea \$ _____
	<p>SAP #6001149</p> <p>CAMCART FOR FOOD PAN – CAPACITY 6 OR 8 PANS Enclosed seamless, one-piece, double-wall insulated cart. Polyethylene exterior. Polyurethane foam insulation. Heavy-duty design with two separate cavities for cold and hot foods. Recessed corrosion-free stainless steel hardware with rubber gasket for air tight closing to seal in heat. 5" - 6" diameter casters. Exterior dimensions with casters to be approximately 20-1/2" W x 27-1/8" D x 45" H. Capacity for 6 each 12-3/4" x 20-7/8" x 4" deep or 8 each 12-3/4" x 20-7/8" x 2-1/2" deep food pans. Manufacturer's standard warranty will apply. Approved Brands: Cambro Model UPC600 or other brands meeting bid specifications Brand Offered: _____ Model Offered: _____ Warranty Period: _____ Delivery (days ARO): _____</p>		

VENDOR NAME: _____
BNG

The School Board of Broward County, Florida
CAFETERIA EQUIPMENT

SECTION 5, BID SUMMARY SHEET (Continued)

		<u>UNIT PRICE</u>	<u>TOTAL COST</u>
ITEM 29: (TO BE AWARDED AS A GROUP) - Continued			
G.	1 each	SAP #6000091 CAMCART FOR FOOD PAN – CAPACITY 16 OR 24 PANS Enclosed seamless, one-piece, double-wall insulated cart. Polyethylene exterior. Polyurethane foam insulation. Heavy-duty design with two separate cavities for cold and hot foods. Recessed corrosion-free stainless steel hardware with rubber gasket for air tight closing to seal in heat. 5" - 6" diameter casters. Exterior dimensions with casters to be approximately 28-1/8" W x 32-1/4" D x 54" H. Capacity for 16 pans 12-3/4" x 20-7/8" x 4" deep or 24 pans 12-3/4" x 20-7/8" x 2-1/2" deep food pans. Manufacturer's standard warranty will apply. Approved Brand: Cambro Model UPC1600 or other brands meeting bid specifications	\$ _____ /ea \$ _____
		Brand Offered: _____	
		Model Offered: _____	
		Warranty Period: _____	
		Delivery (days ARO): _____	
H.	3 each	SAP #6000120 CADDIE, ICE WITH SLIDING LID (TALL) Polyethylene construction body with thick foam insulation to provide long lasting ice storage and easily transportable. Approximate exterior dimensions 23" x 34" x 37 -1/2" with storage capacity of 175 lbs. of ice. Recessed well and drain shelf and recessed handle for easy moving. No assembly required. Two swivel casters, one brake and two rear easy wheels 8" – 10". Manufacturer's standard warranty will apply. <u>Colors:</u> Black, blue, gray and green. Approved Brand: Cambro Model ICS175TB or other brands meeting bid specifications	\$ _____ /ea \$ _____
		Brand Offered: _____	
		Model Offered: _____	
		Warranty Period: _____	
		Delivery (days ARO): _____	

VENDOR NAME: _____
BNG

The School Board of Broward County, Florida
CAFETERIA EQUIPMENT

SECTION 5, BID SUMMARY SHEET (Continued)

		<u>UNIT PRICE</u>	<u>TOTAL COST</u>
ITEM 29: (TO BE AWARDED AS A GROUP) - Continued			
I.	3 each	SAP #6001219	\$ _____ /ea \$ _____
<p>CABINET, HOT BULK FOOD HOLDING/TRANSPORT-LOW PROFILE Plastic-based thermoelectric cart designed for holding and transporting food outdoors. Holds hot food temperatures for minimum of two hours. Thermoelectric unit located on back of unit must be completely enclosed. Air temperature inside cabinet must hold at an even range of 150 – 165 degrees Fahrenheit. 6' long cord with wrapping hook. Control panel has polycarbonate waterproof cover, on/off switch and temperature dial. Double wall polyethylene external construction will not dent, crack, bubble or rust. Aluminum louvers in back wall of cavity direct air flow for even heat. Six universal chrome plated tray rails. Capacity of 12 each 12" x 20" x 2-1/2' deep. Approximate dimensions 30" x 42" x 43" high. Includes two each 6" front swivel with brake casters and two 10" rear rigid casters. 110 v., max. amp. Draw 10, Nema 5-15P plug. Warranty: Two year manufacturer's warranty, all parts and labor must be included in the unit price. Price must include inside delivery and complete operational setup. Approved Brand: Cambro Model CMBH1826LF or other brands meeting bid specifications</p> <p>Brand Offered: _____ Model Offered: _____ Warranty Period: _____ Delivery (days ARO): _____</p>			
J.	1 each	SAP #6001220	\$ _____ /ea \$ _____
<p>CABINET, HOT/COLD BULK FOOD HOLDING/TRANSPORT – LOW PROFILE Plastic-based thermoelectric cart designed for holding and transporting food outdoors. Holds hot food temperatures for minimum of two hours. Thermoelectric unit located on back of unit and must be completely enclosed. Inside cabinet must hold at an even range of 150 -165 degrees Fahrenheit. When cooled to 37 degrees, internal cavity temperature must remain below 41 degrees for a minimum of two hours. 6' long cord with wrapping hook. Control panel has polycarbonate waterproof cover, on/off switch and temperature dial. Double wall polyethylene external construction will not dent, crack, bubble or rust. Aluminum louvers in back wall of cavity direct air flow for even heat. Six universal chrome plated tray rails. Capacity of 12 each 12" x 20" x 2-1/2" deep. Approximate dimensions 30" x 42" x 43" high. Includes two each 6" front swivel with brake casters and two 10" rear rigid casters. 110 v., max. amp. draw 10, Nema 5-15P plug. Warranty: Two year manufacturer's warranty, all parts and labor must be included in the unit price. Price must include inside delivery and complete operational setup. Approved Brand: CMBHC1826LF or other brands meeting bid specifications</p> <p>Brand Offered: _____ Model Offered: _____ Warranty Period: _____ Delivery (days ARO): _____</p>			
TOTAL BID ITEM 29 (A – J inclusive).....			\$ _____

VENDOR NAME: _____
BNG

The School Board of Broward County, Florida
CAFETERIA EQUIPMENT

SECTION 5, BID SUMMARY SHEET (Continued)

		<u>UNIT PRICE</u>	<u>TOTAL COST</u>	
ITEM 30: (TO BE AWARDED AS A GROUP)				
A.	15 each	SAP #6000085 BAR, SALAD – FOUR PAN CAPACITY Mobile insulated self service food bar polyethylene seamless construction, complete unit to be insulated with polyurethane foam. Four full size pan capacity. Storage cabinet with sliding doors below. Casters to be five inch diameter, swivel with brakes including base plate for fastening N.S.F. approved, one piece full-length sneeze guard. Exterior dimensions: 63-1/2" long x 33-1/4" wide x 52-1/2" high. Interior well dimensions: 50-1/16" long x 20-1/8" wide x 6-1/2" deep. Floor to top of well 34-1/2". Top of well to bottom of sneeze guard 10-7/8". Manufacturer's standard warranty will apply. Approved Brand: Cambro "Food Bar" Model 5UBR or other brands meeting bid specifications	\$ _____	/ea \$ _____
Brand Offered: _____				
Model Offered: _____				
Warranty Period: _____				
Delivery (days ARO): _____				
B.	10 each	SAP #6000086 BAR, SALAD – FIVE PAN CAPACITY Mobile insulated self service food bar polyethylene seamless construction, complete unit to be insulated with polyurethane foam. Storage cabinet with sliding doors below. Casters to be five inch diameter, swivel with brakes including base plate for fastening N.S.F. approved, one piece full-length sneeze guard. Exterior dimensions: 71-1/2" long x 32-3/4" wide x 52-1/2" high. Interior well dimensions: 62-7/8" long x 20-1/8" wide x 6-1/2" deep. Floor to top of well 34-1/2". Top of well to bottom of sneeze guard 10-7/8". Manufacturer's standard warranty will apply. Approved Brand: Cambro "Food Bar" Model 6UBR or other brands meeting bid specifications	\$ _____	/ea \$ _____
Brand Offered: _____				
Model Offered: _____				
Warranty Period: _____				
Delivery (days ARO): _____				

VENDOR NAME: _____
BNG

The School Board of Broward County, Florida
CAFETERIA EQUIPMENT

SECTION 5, BID SUMMARY SHEET (Continued)

		<u>UNIT PRICE</u>	<u>TOTAL COST</u>
ITEM 30: (TO BE AWARDED AS A GROUP) - Continued			
C.	10 each	SAP #6000087	\$ _____ /ea \$ _____
		BAR, SALAD – TABLE TOP	
		Mobile insulated self service food bar polyethylene seamless construction, complete unit to be insulated with polyurethane foam. Table top model. One piece full-length N.S.F. listed sneeze guard. To include drain plug. Manufacturer’s standard warranty will apply. Exterior dimensions: 51" long x 33-1/4" high x 27" deep. Approved Brands: Cambro “Food Bar” Model 4FBRTT or other brands meeting bid specifications	
		Brand Offered: _____	
		Model Offered: _____	
		Warranty Period: _____	
		Delivery (days ARO): _____	
D.	15 each	SAP #6002187	\$ _____ /ea \$ _____
		RAIL, ACCESSORY FOR SALAD BAR – FIVE FEET	
		Made of durable lightweight polyethylene five foot long. Must match salad bars. Size: 63-1/2" L x 8" W x 1-1/2" D. Height from floor 34-3/4". Manufacturer’s standard warranty will apply. Approved Brand: Cambro Model FBR5R or other brands meeting bid specifications	
		Brand Offered: _____	
		Model Offered: _____	
		Warranty Period: _____	
		Delivery (days ARO): _____	
E.	5 each	SAP #6002188	\$ _____ /ea \$ _____
		RAIL, ACCESSORY FOR SALAD BAR – SIX FEET	
		Made of durable lightweight polyethylene five foot long. Must match salad bars. Size: 70" L x 8" W x 1-1/2" D. Height from floor 34-3/4". Manufacturer’s standard warranty will apply. Approved Brand: Cambro Model FBR6R or other brands meeting bid specifications	
		Brand Offered: _____	
		Model Offered: _____	
		Warranty Period: _____	
		Delivery (days ARO): _____	

VENDOR NAME: _____
BNG

The School Board of Broward County, Florida
CAFETERIA EQUIPMENT

SECTION 5, BID SUMMARY SHEET (Continued)

		<u>UNIT PRICE</u>	<u>TOTAL COST</u>
ITEM 30: (TO BE AWARDED AS A GROUP) - Continued			
F.	50 each	SAP # _____	\$ _____ /ea \$ _____
		VERSA CART W/DUAL TRAY RAILS	
		52-3/4" wide x 32" deep x 43-3/4" high, with five inch heavy duty casters (two fixed and two swivel with brakes), seamless one-piece polyethylene construction to include dual tray rails. Manufacturer's standard warranty will apply. Ergonomic molded-in handles for easy maneuvering. Sneeze guards and tray slides fold down to fit through a standard 3' door. At least four colors to choose from, tray rails must be available in same colors as cart. Inside delivery, full assembly, set in place required.	
		Approved Brands: Cambro Model VCSWRHD or other brands meeting bid specifications	
		Brand Offered: _____	
		Model Offered: _____	
		Warranty Period: _____	
		Delivery (days ARO): _____	
G.	10 each	SAP # _____	\$ _____ /ea \$ _____
		VERSA WORK TABLE – FIVE FEET	
		Mobile insulated self-service food bar polyethylene seamless construction, complete unit to be insulated with polyurethane foam. Heavy duty casters to be five inch diameter, swivel with brakes including base plate for fastening. Ergonomic molded-in handles for easy maneuvering. Fits through a standard 3' door. Exterior dimensions: Approx. 69" long x 27" wide x 36-1/4" x 36-1/4" high. Interior well dimensions: Approx. 59-9/32" long x 21" wide x 7-1/8" deep. Top of well to bottom of sneeze guard approx. 10-7/8". Manufacturer's standard warranty will apply. Inside delivery, full assembly, set in place required. N.S.F. approved.	
		Approved Brand: Cambro Model VBRTHD5 or other brands meeting bid specifications	
		Brand Offered: _____	
		Model Offered: _____	
		Warranty Period: _____	
		Delivery (days ARO): _____	

TOTAL BID ITEM 30 (A – G inclusive)..... \$ _____

VENDOR NAME: _____
BNG

The School Board of Broward County, Florida
CAFETERIA EQUIPMENT

SECTION 5, BID SUMMARY SHEET (Continued)

NOTE: SERVING LINES MAY BE ORDERED IN ANY CONFIGURATION OF ITEMS LISTED BELOW. AWARDED VENDOR IS NOT RESPONSIBLE FOR ELECTRICAL OR PLUMBING HOOK-UP. BIDDER MUST OFFER ONE MANUFACTURER THROUGHOUT FOR ALL ITEMS LISTED. SEE SPECIAL CONDITION 13 – INSTALLATION. ALL MOLDED BODIES TO HAVE FIVE YEAR WARRANTY.

<u>ITEM 31:</u>	<u>(TO BE AWARDED AS A GROUP)</u>	<u>UNIT PRICE</u>	<u>TOTAL COST</u>
A.	<p>1 each SAP #6001143 TABLE, ELECTRIC HOT FOOD SERVING, OPEN BASE – 50” Unit to have fiberglass reinforced polyester (F.R.P.) molded with permanent color or 18-8 type 304 stainless steel with smooth exterior surfaces and rounded corners. All fiberglass to be flame retardant per specification ASTM E-162. Body to be 50" long and 28" - 30" wide (top) and available in 34", 35", and 36" heights. Body constructed to accommodate tray rail at heights of 32", 33", and 34". (Bid does not include tray rail.) Body constructed with internal support member fabricated of a minimum of 14 gauge galvaneal channel to securely fasten tray rail support brackets. Provide with six inch stainless steel adjustable legs. Internal framing is to be 4-1/2" wide, galvaneal channel, shall be mounted vertically on front and bottom surfaces and across the interior bottom to form a "U" shaped channel frame. "U" frame mounted at leg attachment location. Internal framing "U" channel 3 1/2" – 4-1/2" wide on operators side. Exterior 20 gauge stainless steel channel mounted between bottom of fiberglass body and legs to provide maximum stress relief. (See Attachment A) Top shall be constructed of 14 gauge, Grade 18-8 stainless steel with a number four finish, welded, ground and polished. Top shall have three individual 12" x 20" die stamped openings for individual recessed electrically heated stainless steel hot food wells with three individual controls, each rated at 500 watts at 208 VAC. Wells pre-wired to a circuit breaker mounted in the control panel for overload protection. Dry/moist electric hot food wells to be bottom mounted and have 12" x 20" die stamped opening with 1/4" raised beaded edge. Provide access panel inside storage base for access to hot food wells from below counter top required. All hot food wells and elements need to be accessed without cutting hole in table. Each drain from hot well shall contain a union to facilitate ease of removal of hot wells. Drains to be 3/4" and pre-piped to a common manifold with a 1/4" turn ball valve as shut-off. Shut-off valve to be 6" from operator underneath unit. <u>Full length open under storage constructed of 18 gauge stainless steel with coved vertical and horizontal corners.</u> U.L. Listed for safety. U.L. Sanitation Certified or N.S.F. listed. Electric: 208Volt, One or Three Phase. Warranty: Two year manufacturer’s warranty, all parts and labor must be included in the unit price. Approved Brand: Colorpoint Model 5E3CPA or Delfield Model KH-3-NU-MB or other brands meeting bid specifications Brand Offered: _____ Model Offered: _____ Warranty Period: _____ Delivery (days ARO): _____</p>	\$ _____	/ea \$ _____

VENDOR NAME: _____
BNG

The School Board of Broward County, Florida
CAFETERIA EQUIPMENT

SECTION 5, BID SUMMARY SHEET (Continued)

		<u>UNIT PRICE</u>	<u>TOTAL COST</u>
ITEM 31:	<u>(TO BE AWARDED AS A GROUP) – Continued</u>		
B.	8 each SAP #6001114	\$ _____	/ea \$ _____
	TABLE, ELECTRIC HOT FOOD SERVING, OPEN BASE – 60”		
	Unit to have fiberglass reinforced polyester (F.P.R.) molded with permanent color <u>or</u> 18-8 type 304 stainless steel with smooth exterior surfaces and rounded corners. All fiberglass to be flame retardant per specification ASTM E-162. Body to be 60" long, 28" - 30" wide (top) and available in 34", 35", and 36" heights. Body constructed to accommodate tray rail at heights of 32", 33", and 34". (Bid does not include tray rail.) Body constructed with internal support member fabricated of a minimum of 14 gauge galvaneal channel to securely fasten tray rail support brackets. Provide with six inch stainless steel adjustable legs. Internal framing is to be 4-1/2" wide, galvaneal channel, shall be mounted vertically on front and rear surfaces and across the interior bottom to form a "U" shaped channel frame. "U" frame mounted at leg attachment location. "U" channel to be 3-1/2" – 4-1/2" wide on operators side. Exterior 20 gauge stainless steel channel mounted between bottom of fiberglass body and legs to provide maximum stress relief.		
	(See Attachment A)		
	Top shall be constructed of 14 gauge, Grade 18-8 stainless steel with a number four finish, welded, ground and polished. Top shall have four individual 12" x 20" die stamped openings for individual recessed electrically heated stainless steel hot food wells with drains and four individual controls, each rated at 500 watts at 208 VAC. Wells pre-wired to a circuit breaker mounted in the control panel for overload protection. Dry/moist electric hot food wells to be bottom mounted and have a 12" x 20" die stamped opening with 1/4" raised beaded edge. <u>Provide access panel inside storage base for access to hot food wells from below counter top required.</u> All hot food wells and elements need to be accessed without cutting hole in table. <u>Each drain from hot well shall contain a union to facilitate ease of removal of hot wells.</u> Drains to be 3/4" and prepiped to a common manifold with a 1/4" turn ball valve as shut-off. Shut-off valve to be six inch from operator underneath unit. <u>Full length open under storage constructed of 18 gauge stainless steel with coved vertical and horizontal corners.</u> U.L. Listed for safety. U.L. Sanitation Certified or N.S.F. listed. Warranty: Two year manufacturer's warranty, all parts and labor must be included in the unit price.		
	Approved Brands: Colorpoint Model 5E4-CPA, Delfield KH-4-NU-MB or other brands meeting bid specifications		
	Brand Offered: _____		
	Model Offered: _____		
	Warranty Period: _____		
	Delivery (days ARO): _____		

VENDOR NAME: _____
BNG

The School Board of Broward County, Florida
CAFETERIA EQUIPMENT

SECTION 5, BID SUMMARY SHEET (Continued)

		<u>UNIT PRICE</u>	<u>TOTAL COST</u>
ITEM 31:	<u>(TO BE AWARDED AS A GROUP) – Continued</u>		
C.	40 each	\$ _____	/ea \$ _____
	<p>SAP #6000099 TABLE, ELECTRIC HOT FOOD SERVING, OPEN BASE – 74” Unit to have fiberglass reinforced polyester (F.P.R.) molded with permanent color <u>or</u> 18-8 type 304 stainless steel with smooth exterior surfaces and rounded corners. All fiberglass to be flame retardant per specification ASTM E-162. Body to be 74" long and 30" wide (top) and available in 34", 35", and 36" heights. Body constructed to accommodate tray rail at heights of 32", 33", and 34". (Bid does not include tray rail.) Body constructed with internal support member fabricated of a minimum of 14 gauge galvaneal channel to securely fasten tray rail support brackets. Provide with six inch stainless steel adjustable legs. Internal framing is to be 4-1/2" wide, galvaneal channel, shall be mounted vertically on front and rear surfaces and across the interior bottom to form a "U" shaped channel frame. "U" frame mounted at leg attachment location. "U" channel to be 3-1/2" – 4-1/2" wide on operators side. Exterior 20 gauge stainless steel channel mounted between bottom of fiberglass body and legs to provide maximum stress relief. (See Attachment A) Top shall be constructed of 14 gauge, Grade 18-8 stainless steel with a number four finish, welded, ground and polished. Top shall have five individual 12" x 20" die stamped openings for individual recessed electrically heated stainless steel hot food wells with drains and five individual controls, each rated at 500 watts at 208 VAC. All wells pre-wired to a circuit breaker mounted in the control panel for overload protection. Dry/moist electric hot food wells to be bottom mounted and have a 12" x 20" die stamped opening with 1/4" raised beaded edge. Provide access panel inside storage base for access to hot food wells from below counter top required. All hot food wells and elements need to be accessed without cutting hole in table. Each drain from hot well shall contain a union to facilitate ease of removal of hot well. Drains to be 3/4" and prepiped to a common manifold with a 1/4" turn ball valve as shut-off. Shut-off valve to be six inch from operator underneath unit. Full length open under storage constructed of 18 gauge stainless steel with <u>coved vertical and horizontal corners</u>. U.L. Listed for safety. U.L. Sanitation Certified or N.S.F. listed. Warranty: Two year manufacturer’s warranty, all parts and labor must be included in the unit price. Approved Brands: Colorpoint Model 5E5-CPA, Delfield Model KH-5NU-MB or other brands meeting bid specifications</p> <p>Brand Offered: _____ Model Offered: _____ Warranty Period: _____ Delivery (days ARO): _____</p>		

VENDOR NAME: _____
BNG

The School Board of Broward County, Florida
CAFETERIA EQUIPMENT

SECTION 5, BID SUMMARY SHEET (Continued)

		<u>UNIT PRICE</u>	<u>TOTAL COST</u>
ITEM 31:	<u>(TO BE AWARDED AS A GROUP) – Continued</u>		
D.	10 each	SAP # _____ \$ _____	/ea \$ _____
	<p>TABLE, ELECTRIC HOT FOOD SERVING, OPEN BASE – 84” Unit to have fiberglass reinforced polyester (F.R.P.) molded with permanent color or 18-8 type 304 stainless steel with smooth exterior surfaces and rounded corners. All fiberglass to be flame retardant per specification ASTM E-162. Body to be 84" long and 28" - 30" wide (top) and available in 34", 35", and 36" heights. Body constructed to accommodate tray rail at heights of 32", 33", and 34". (Bid does not include tray rail.) Body constructed with internal support member fabricated of a minimum of 14 gauge galvaneal channel to securely fasten tray rail support brackets. Provide with six inch stainless steel adjustable legs. Internal framing is to be 4-1/2" wide, galvaneal channel, shall be mounted vertically on front and bottom surfaces and across the interior bottom to form a "U" shaped channel frame. "U" frame mounted at leg attachment location. Internal framing "U" channel 3 1/2" – 4-1/2" wide on operators side. Exterior 20 gauge stainless steel channel mounted between bottom of fiberglass body and legs to provide maximum stress relief. (See Attachment A) Top shall be constructed of 14 gauge, Grade 18-8 stainless steel with a number four finish, welded, ground and polished. Top shall have four individual 12" x 20" die stamped openings for individual recessed electrically heated stainless steel hot food wells with four individual controls, each rated at 900-1,000 watts at 208 VAC. Unit to have approximately 24" of flat top space with 30" heat strip centered over flat top area and one hot food well. This space is to serve pizza. Wells pre-wired to a circuit breaker mounted in the control panel for overload protection. Dry/moist electric hot food wells to be bottom mounted and have 12" x 20" die stamped opening with 1/4" raised beaded edge. Provide access panel inside storage base for access to hot food wells from below counter top required. All hot food wells and elements need to be accessed without cutting hole in table. Each drain from hot well shall contain a union to facilitate ease of removal of hot wells. Drains to be 3/4" and pre-piped to a common manifold with a 1/4" turn ball valve as shut-off. Shut-off valve to be 6" from operator underneath unit. <u>Full length open under storage constructed of 18 gauge stainless steel with covered vertical and horizontal corners.</u> U.L. Listed for safety. U.L. Sanitation Certified or N.S.F. listed. Electric: 208Volt, One or Three Phase. Warranty: Two year manufacturer’s warranty, all parts and labor must be included in the unit price. Approved Brand: Colorpoint Model EF5-CPA-84-MOD or Delfield Model KH-5-NU-MB-MOD or other brands meeting bid specifications Brand Offered: _____ Model Offered: _____ Warranty Period: _____ Delivery (days ARO): _____</p>		

VENDOR NAME: _____
BNG

The School Board of Broward County, Florida
CAFETERIA EQUIPMENT

SECTION 5, BID SUMMARY SHEET (Continued)

		<u>UNIT PRICE</u>		<u>TOTAL COST</u>
ITEM 31:	(TO BE AWARDED AS A GROUP) – Continued			
E.	6 each SAP #6001117	\$ _____	/ea	\$ _____
	TABLE, ICE COOLED COLD – OPEN BASE – 30”			
	Body to be seamless mold fiberglass with smooth exterior surfaces and rounded corners <u>or</u> 18-8 type 304 stainless steel with smooth exterior surfaces and rounded corners. All fiberglass to be flame retardant per specifications ASTM E-162. To be 28" - 30" wide x 30" long and available in 34", 35", and 36" heights. Body constructed to accommodate tray rail at heights of 32", 33", and 34". (Bid does not include tray rail.) Top to be fabricated from 14 gauge stainless steel with square turndown on all sides and corners fully welded, ground, and polished with #4 finish. Body constructed with internal support member fabricated of a minimum of 12 gauge galvaneal channel to securely fasten tray rail support brackets. Provide with six inch stainless steel adjustable legs. Internal framing is to be 4-1/2" wide, galvaneal channel, shall be mounted vertically on front and rear surfaces and across the interior bottom to form a "U" shaped channel frame. "U" frame mounted at leg attachment location. "U" channel to be 3-1/2" – 4-1/2" wide on operators side. Exterior 20 gauge stainless steel channel mounted between bottom of fiberglass body and legs to provide maximum stress relief. (See Attachment A)			
	The ice cold pan to be 18 gauge stainless steel and six inch deep. Pan to be welded, watertight and fully insulated with urethane insulation and removable false bottom. To have full perimeter Formica breaker strip to separate the top from the cold pan. To have drain with extension to shut-off valve below base. Open under storage to be lined with 18 gauge stainless steel <u>coved vertical and horizontal corners</u> . With six inch stainless steel adjustable legs. Bid price to include adapter plate for 18" x 26" sheet pan. U.L. Listed and N.S.F. Approved. Warranty: Two year manufacturer’s warranty, all parts and labor must be included in the unit price.			
	Approved Brands: Colorpoint Model 36-CFI Modified to 30” long, Delfield Model KCI-36-NU-MB or other brands meeting bid specifications			

Brand Offered: _____
Model Offered: _____
Warranty Period: _____
Delivery (days ARO): _____

VENDOR NAME: _____
BNG

The School Board of Broward County, Florida
CAFETERIA EQUIPMENT

SECTION 5, BID SUMMARY SHEET (Continued)

		<u>UNIT PRICE</u>	<u>TOTAL COST</u>
ITEM 31:	<u>(TO BE AWARDED AS A GROUP) – Continued</u>		
F.	10 each	\$ _____	/ea \$ _____
	<p>SAP #6001118 TABLE, ICE COOLED COLD – OPEN BASE – 36” Body to be seamless mold fiberglass with smooth exterior surfaces and rounded corners <u>or</u> 18-8 type 304 stainless steel with smooth exterior surfaces and rounded corners. All fiberglass to be flame retardant per specifications ASTM E-162. To be 28" - 30" wide x 36" long and available in 34", 35", and 36" heights. Body constructed to accommodate tray rail at heights of 32", 33", and 34". (Bid does not include tray rail.) Top to be fabricated from 14 gauge stainless steel with square turndown on all sides and corners fully welded, ground, and polished with #4 finish. Cold pan to accommodate two 12" x 20" hotel pans or one 18" x 26" sheet pan. Body constructed with internal support members fabricated of a minimum of 12 gauge galvaneal channel to securely fasten tray rail support brackets. Provide with six inch stainless steel adjustable legs. Internal framing is to be 4-1/2" wide, galvaneal channel, shall be mounted vertically on front and rear surfaces and across the interior bottom to form a "U" shaped channel frame. "U" frame mounted at leg attachment location. "U" channel to be 3-1/2" – 4-1/2" wide on operators side. Exterior 20 gauge stainless steel channel mounted between bottom of fiberglass body and legs to provide maximum stress relief. (See Attachment A)</p> <p>The ice cold pan to be 18 gauge stainless steel and six inch deep. Pan to be welded, watertight and fully insulated with urethane insulation and removable false bottom. To have full perimeter Formica breaker strip to separate the top from the cold pan. To have drain with extension to shut-off valve below base. Open under storage to be lined with 18 gauge stainless steel <u>coved vertical and horizontal corners</u>. With six inch stainless steel adjustable legs. Bid price to include adapter plate for 18" x 26" sheet pan. U.L. Listed and N.S.F. Approved. Warranty: Two year manufacturer’s warranty, all parts and labor must be included in the unit price. Approved Brands: Colorpoint Model 36-CFI Modified, Delfield Model KCI-36-NU-MB or other brands meeting bid specifications</p> <p>Brand Offered: _____ Model Offered: _____ Warranty Period: _____ Delivery (days ARO): _____</p>		

VENDOR NAME: _____
BNG

The School Board of Broward County, Florida
CAFETERIA EQUIPMENT

SECTION 5, BID SUMMARY SHEET (Continued)

		<u>UNIT PRICE</u>	<u>TOTAL COST</u>
ITEM 31:	<u>(TO BE AWARDED AS A GROUP) – Continued</u>		
G.	50 each	\$ _____	/ea \$ _____
	<p>SAP #6000109 TABLE, ICE COOLED COLD – OPEN BASE – 50-51” Body to be constructed of fiberglass panels with vertical and horizontal stainless steel trim <u>or</u> 18-8 type 304 stainless steel with smooth exterior surfaces and rounded corners. All fiberglass to be flame retardant per specifications ASTM E-162. To be 34" wide x 50" - 51" long and available in 34", 35", and 36" heights. Body constructed to accommodate tray rail at heights of 32", 33", and 34". (Bid does not include tray rail.) Top to be fabricated from 14 gauge stainless steel with square turndown on all sides and corners fully welded, ground, and polished with #4 finish. Body constructed with internal support member fabricated of a minimum of 12 gauge galvaneal channel to securely fasten tray rail support brackets. Provide with 6" stainless steel adjustable legs. Internal framing is to be 4-1/2" wide, galvaneal channel, shall be mounted vertically on front and rear surfaces and across the interior bottom to form a "U" shaped channel frame. "U" frame mounted at leg attachment location. "U" channel to be 3-1/2" – 4-1/2" wide on operators side. Exterior 20 gauge stainless steel channel mounted between bottom of fiberglass body and legs to provide maximum stress relief. (See Attachment A)</p> <p>The ice cold pan to be 18 gauge stainless steel and 6" deep. Pan to be welded, watertight and fully insulated with urethane insulation and removable false bottom. To have full perimeter Formica breaker strip to separate the top from the cold pan. To have drain with extension to shut-off valve below base. Open under storage to be lined with 18 gauge stainless steel <u>coved vertical and horizontal corners</u>. With 6" stainless steel adjustable legs. U.L. Listed and N.S.F. Approved. Warranty: Two year manufacturer’s warranty, all parts and labor must be included in the unit price. Approved Brands: Colorpoint Model 50-CFI, Delfield Model KCI-50-NU-MB or other brands meeting bid specifications</p> <p>Brand Offered: _____ Model Offered: _____ Warranty Period: _____ Delivery (days ARO): _____</p>		

VENDOR NAME: _____
BNG

The School Board of Broward County, Florida
CAFETERIA EQUIPMENT

SECTION 5, BID SUMMARY SHEET (Continued)

		<u>UNIT PRICE</u>	<u>TOTAL COST</u>
ITEM 31:	<u>(TO BE AWARDED AS A GROUP) – Continued</u>		
H.	SAP # _____	\$ _____	/ea \$ _____
12	TABLE, ICE COOLED COLD – OPEN BASE – 60-61”		
each	<p>Body to be constructed of fiberglass panels with vertical and horizontal stainless steel trim <u>or</u> 18-8 type 304 stainless steel with smooth exterior surfaces and rounded corners. All fiberglass to be flame retardant per specifications ASTM E-162. To be 30" wide x 60" - 61" long and available in 34", 35", and 36" heights. Body constructed to accommodate tray rail at heights of 32", 33", and 34". (Bid does not include tray rail.) Top to be fabricated from 14 gauge stainless steel with square turndown on all sides and corners fully welded, ground, and polished with #4 finish. Body constructed with internal support member fabricated of a minimum of 12 gauge galvaneal channel to securely fasten tray rail support brackets. Provide with 6" stainless steel adjustable legs. Internal framing is to be 4-1/2" wide, galvaneal channel, shall be mounted vertically on front and rear surfaces and across the interior bottom to form a "U" shaped channel frame. "U" frame mounted at leg attachment location. "U" channel to be 3-1/2" – 4-1/2" wide on operators side. Exterior 20 gauge stainless steel channel mounted between bottom of fiberglass body and legs to provide maximum stress relief. (See Attachment A)</p> <p>The ice cold pan to be 18 gauge stainless steel and 6" deep. Pan to be welded, watertight and fully insulated with urethane insulation and removable false bottom. To have full perimeter Formica breaker strip to separate the top from the cold pan. To have drain with extension to shut-off valve below base. Open under storage to be lined with 18 gauge stainless steel <u>coved vertical and horizontal corners</u>. With 6" stainless steel adjustable legs. U.L. Listed and N.S.F. Approved. Warranty: Two year manufacturer’s warranty, all parts and labor must be included in the unit price. Approved Brands: Colorpoint Model 60-CFI, Delfield Model KCI-60-NU-MB or other brands meeting bid specifications</p> <p>Brand Offered: _____ Model Offered: _____ Warranty Period: _____ Delivery (days ARO): _____</p>		

VENDOR NAME: _____
BNG

The School Board of Broward County, Florida
CAFETERIA EQUIPMENT

SECTION 5, BID SUMMARY SHEET (Continued)

		<u>UNIT PRICE</u>	<u>TOTAL COST</u>
ITEM 31:	<u>(TO BE AWARDED AS A GROUP) – Continued</u>		
I.	12 each	\$ _____	/ea \$ _____
	<p>SAP # _____</p> <p>TABLE, ICE COOLED COLD – OPEN BASE – 66 3/8”</p> <p>Body to be constructed of fiberglass panels with vertical and horizontal stainless steel trim <u>or</u> 18-8 type 304 stainless steel with smooth exterior surfaces and rounded corners. All fiberglass to be flame retardant per specifications ASTM E-162. To be 30" wide x 66" – 67" long and available in 34", 35", and 36" heights. Body constructed to accommodate tray rail at heights of 32", 33", and 34" (Bid does not include tray rail). Top to be fabricated from 14 gauge stainless steel with square turndown on all sides and corners fully welded, ground, and polished with #4 finish. Body constructed with internal support member fabricated of a minimum of 12 gauge galvaneal channel to securely fasten tray rail support brackets. Provide with 6" stainless steel adjustable legs. Internal framing is to be 4-1/2" wide, galvaneal channel, shall be mounted vertically on front and rear surfaces and across the interior bottom to form a "U" shaped channel frame. "U" frame mounted at leg attachment location. "U" channel to be 3-1/2" – 4-1/2" wide on operators side. Exterior 20 gauge stainless steel channel mounted between bottom of fiberglass body and legs to provide maximum stress relief. (See Attachment A)</p> <p>The ice cold pan to be 18 gauge stainless steel and 6" deep. Pan to be welded, watertight and fully insulated with urethane insulation and removable false bottom. To have full perimeter Formica breaker strip to separate the top from the cold pan. To have drain with extension to shut-off valve below base. Storage for 3 each 12" x 20" steamable pans in the cold pan and one 18" x 26" steet pan on the flat top. Open under storage to be lined with 18 gauge stainless steel <u>coved vertical and horizontal corners</u>. With 6" stainless steel adjustable legs. U.L. Listed and N.S.F. Approved.</p> <p>Warranty: Two year manufacturer’s warranty, all parts and labor must be included in the unit price.</p> <p>Approved Brands: Colorpoint Model 66-CFI MOD, Delfield Model KCI-66-NU-MB MOD or other brands meeting bid specifications</p> <p>Brand Offered: _____</p> <p>Model Offered: _____</p> <p>Warranty Period: _____</p> <p>Delivery (days ARO): _____</p>		

VENDOR NAME: _____
BNG

The School Board of Broward County, Florida
CAFETERIA EQUIPMENT

SECTION 5, BID SUMMARY SHEET (Continued)

		<u>UNIT PRICE</u>	<u>TOTAL COST</u>
ITEM 31:	<u>(TO BE AWARDED AS A GROUP) – Continued</u>		
J.	12 each	\$ _____	/ea \$ _____
	<p>SAP # _____</p> <p>TABLE, ICE COOLED COLD – OPEN BASE – 74 3/8”</p> <p>Body to be constructed of fiberglass panels with vertical and horizontal stainless steel trim <u>or</u> 18-8 type 304 stainless steel with smooth exterior surfaces and rounded corners. All fiberglass to be flame retardant per specifications ASTM E-162. To be 30" wide x 74" - 75" long and available in 34", 35", and 36" heights. Body constructed to accommodate tray rail at heights of 32", 33", and 34" (Bid does not include tray rail). Top to be fabricated from 14 gauge stainless steel with square turndown on all sides and corners fully welded, ground, and polished with #4 finish. Body constructed with internal support member fabricated of a minimum of 12 gauge galvaneal channel to securely fasten tray rail support brackets. Provide with 6" stainless steel adjustable legs. Internal framing is to be 4-1/2" wide, galvaneal channel, shall be mounted vertically on front and rear surfaces and across the interior bottom to form a "U" shaped channel frame. "U" frame mounted at leg attachment location. "U" channel to be 3-1/2" – 4-1/2" wide on operators side. Exterior 20 gauge stainless steel channel mounted between bottom of fiberglass body and legs to provide maximum stress relief. (See Attachment A)</p> <p>The ice cold pan to be 18 gauge stainless steel and 6" deep. Pan to be welded, watertight and fully insulated with urethane insulation and removable false bottom. To have full perimeter Formica breaker strip to separate the top from the cold pan. To have drain with extension to shut-off valve below base. Storage for 3 each 12" x 20" steamable pans in the cold pan and one 18" x 26" steet pan on the flat top. Open under storage to be lined with 18 gauge stainless steel <u>coved vertical and horizontal corners</u>. With 6" stainless steel adjustable legs. U.L. Listed and N.S.F. Approved.</p> <p>Warranty: Two year manufacturer’s warranty, all parts and labor must be included in the unit price.</p> <p>Approved Brands: Colorpoint Model 74-CFI MOD, Delfield Model KCI-74-NU-MB MOD or other brands meeting bid specifications</p> <p>Brand Offered: _____</p> <p>Model Offered: _____</p> <p>Warranty Period: _____</p> <p>Delivery (days ARO): _____</p>		

VENDOR NAME: _____
BNG

The School Board of Broward County, Florida
CAFETERIA EQUIPMENT

SECTION 5, BID SUMMARY SHEET (Continued)

		<u>UNIT PRICE</u>		<u>TOTAL COST</u>
ITEM 31:	<u>(TO BE AWARDED AS A GROUP) – Continued</u>			
K.	3 each	\$ _____	/ea	\$ _____
	<p>SAP #6001122 TABLE, SOLID TOP WITH OPEN BASE – 30” (SERVING LINE) Body to be seamless mold fiberglass with smooth exterior surfaces and rounded corners <u>or</u> 18-8 type 304 stainless steel with smooth exterior surfaces and rounded corners. All fiberglass to be flame retardant per specifications ASTM E-162. To be 28" - 30" wide x 30" long and available in 34", 35", and 36" heights. Body constructed to accommodate tray rail at heights of 32", 33", and 34". (Bid does not include tray rail.) Top to be fabricated from 14 gauge stainless steel with square turndown on all sides and corners fully welded, ground, and polished with #4 finish. Provide with six inch stainless steel adjustable legs. Body constructed with internal support member fabricated of a minimum of 12 gauge galvaneal channel to securely fasten tray rail support brackets. Internal framing is to be 4-1/2" wide, galvaneal channel, shall be mounted vertically on front and rear surfaces and across the interior bottom to form a "U" shaped channel frame. "U" frame mounted at leg attachment location. "U" channel to be 3-1/2" – 4-1/2" wide on operators side. Exterior 20 gauge stainless steel channel mounted between bottom of fiberglass body and legs to provide maximum stress relief. (See Attachment A) Open under storage to be lined with 18 gauge stainless steel with <u>coved vertical and horizontal corners</u>. Warranty: Two year manufacturer’s warranty, all parts and labor to be included in the unit price. Approved Brands: Colorpoint Model 28-ST Modified, Delfield Model KC-28-NU-MB or other brands meeting bid specifications.</p> <p>Brand Offered: _____ Model Offered: _____ Warranty Period: _____ Delivery (days ARO): _____</p>			

VENDOR NAME: _____
BNG

The School Board of Broward County, Florida
CAFETERIA EQUIPMENT

SECTION 5, BID SUMMARY SHEET (Continued)

		<u>UNIT PRICE</u>		<u>TOTAL COST</u>
ITEM 31:	<u>(TO BE AWARDED AS A GROUP) – Continued</u>			
L.	3 each	\$ _____	/ea	\$ _____
	<p>SAP #6001119 TABLE, SOLID TOP WITH OPEN BASE – 36” (SERVING LINE) Body to be seamless mold fiberglass with smooth exterior surfaces and rounded corners or 18-8 type 304 stainless steel with smooth exterior surfaces and rounded corners. All fiberglass to be flame retardant per specifications ASTM E-162. To be 28" - 30" wide x 36" long and available in 34", 35", and 36" heights. Body constructed to accommodate tray rail at heights of 32", 33", and 34". (Bid does not include tray rail.) Top to be fabricated from 14 gauge stainless steel with square turndown on all sides and corners fully welded, ground, and polished with #4 finish. Provide with six inch stainless steel adjustable legs. Body constructed with internal support member fabricated of a minimum of 12 gauge galvaneal channel to securely fasten tray rail support brackets. Internal framing is to be 4-1/2" wide, galvaneal channel, shall be mounted vertically on front and rear surfaces and across the interior bottom to form a "U" shaped channel frame. "U" frame mounted at leg attachment location. "U" channel to be 3-1/2" – 4-1/2" wide on operators side. Exterior 20 gauge stainless steel channel mounted between bottom of fiberglass body and legs to provide maximum stress relief. (See Attachment A) Open under storage to be lined with 18 gauge stainless steel with <u>coved vertical and horizontal corners</u>. An intermediate shelf shall have the rear and ends turned up and secured to interior liner. Warranty: Two year manufacturer’s warranty, all parts and labor to be included in the unit price. Approved Brands: Colorpoint Model 36-ST, Delfield Model KC-36-NU-MB or other brands meeting bid specifications</p> <p>Brand Offered: _____ Model Offered: _____ Warranty Period: _____ Delivery (days ARO): _____</p>			

VENDOR NAME: _____
BNG

The School Board of Broward County, Florida
CAFETERIA EQUIPMENT

SECTION 5, BID SUMMARY SHEET (Continued)

		<u>UNIT PRICE</u>	<u>TOTAL COST</u>
ITEM 31:	<u>(TO BE AWARDED AS A GROUP) – Continued</u>		
M.	6 each SAP #6001146	\$ _____	/ea \$ _____
	<p>TABLE, SOLID TOP WITH OPEN BASE – 42” (SERVING LINE) Body to be constructed of fiberglass panels with vertical and horizontal stainless steel trim <u>or</u> 18-8 type 304 stainless steel with smooth exterior surfaces and rounded corners. All fiberglass to be flame retardant per specifications ASTM-162. To be 38" - 30" wide x approx. 42" long. Must accommodate two each 18" x 26" bun pans sitting side by side. Available in 34", 35", and 36" heights. Body constructed to accommodate tray rail at heights of 32", 33", and 34". (Bid does not include tray rail.) Top to be fabricated from 14 gauge stainless steel with square turndown on all sides and corners fully welded, ground, and polished with #4 finish. Provide with six inch stainless steel adjustable legs. Body constructed with internal support member fabricated of a minimum of 12 gauge galvaneal channel to securely fasten tray rail support brackets. Internal framing is to be 4-1/2" wide, galvaneal channel, shall be mounted vertically on front and rear surfaces and across the interior bottom to form a "U" shaped channel frame. "U" frame mounted at leg attachment location. "U" channel to be 3-1/2" – 4-1/2" wide on operators side. Exterior 20 gauge stainless steel channel mounted between bottom of fiberglass body and legs to provide maximum stress relief. (See Attachment A) Open under storage to be lined with 18 gauge stainless steel with <u>coved vertical and horizontal corners</u>. An intermediate shelf shall have the rear and ends turned up and secured to interior liner. Warranty: Two year manufacturer’s warranty, all parts and labor to be included in the unit price. Approved Brands: Colorpoint Model 36ST-MOD, Delfield Model KC-36-NU-MB or other brands meeting bid specifications</p> <p>Brand Offered: _____ Model Offered: _____ Warranty Period: _____ Delivery (days ARO): _____</p>		

VENDOR NAME: _____
BNG

The School Board of Broward County, Florida
CAFETERIA EQUIPMENT

SECTION 5, BID SUMMARY SHEET (Continued)

		<u>UNIT PRICE</u>	<u>TOTAL COST</u>
<u>ITEM 31:</u>			
<u>(TO BE AWARDED AS A GROUP) – Continued</u>			
N.	12 each	\$ _____	/ea \$ _____
	<p>SAP #6000100 TABLE, SOLID TOP WITH OPEN BASE – 50” (SERVING LINE) Body to be seamless mold fiberglass with smooth exterior surfaces and rounded corners <u>or</u> 18-8 type 304 stainless steel with smooth exterior surfaces and rounded corners. All fiberglass to be flame retardant per specifications ASTM E-162. To be 28" - 30" wide x 50" long and available in 34", 35", and 36" heights. Body constructed to accommodate tray rail at heights of 32", 33", and 34". (Bid does not include tray rail.) Top to be fabricated from 14 gauge stainless steel with square turndown on all sides and corners fully welded, ground, and polished with #4 finish. Provide with six inch stainless steel adjustable legs. Body constructed with internal support member fabricated of a minimum of 12 gauge galvaneal channel to securely fasten tray rail support brackets. Internal framing is to be 4-1/2" wide, galvaneal channel, shall be mounted vertically on front and rear surfaces and across the interior bottom to form a "U" shaped channel frame. "U" frame mounted at leg attachment location. "U" channel to be 3-1/2" – 4-1/2" wide on operators side. Exterior 20 gauge stainless steel channel mounted between bottom of fiberglass body and legs to provide maximum stress relief. (See Attachment A) Open under storage to be lined with 18 gauge stainless steel with <u>coved vertical and horizontal corners</u>. An intermediate shelf shall have the rear and ends turned up and secured to interior liner. Warranty: Two year manufacturer’s warranty, all parts and labor must be included in the unit price. Approved Brands: Colorpoint Model 50-ST, Delfield Model KC-50-NU-MB or other brands meeting bid specifications</p> <p>Brand Offered: _____ Model Offered: _____ Warranty Period: _____ Delivery (days ARO): _____</p>		

VENDOR NAME: _____
BNG

The School Board of Broward County, Florida
CAFETERIA EQUIPMENT

SECTION 5, BID SUMMARY SHEET (Continued)

		<u>UNIT PRICE</u>	<u>TOTAL COST</u>
ITEM 31:	<u>(TO BE AWARDED AS A GROUP) – Continued</u>		
O.	20 each	\$ _____	/ea \$ _____
	<p>SAP #6001120</p> <p>TABLE, SOLID TOP WITH OPEN BASE – 60” (SERVING LINE)</p> <p>Body to be seamless mold fiberglass with smooth exterior surfaces and rounded corners <u>or</u> 18-8 type 304 stainless steel with smooth exterior surfaces and rounded corners. All fiberglass to be flame retardant per specifications ASTM E-162. To be 28" - 30" wide x 60" long and available in 34", 35", and 36" heights. Body constructed to accommodate tray rail at heights of 32", 33", and 34". (Bid does not include tray rail.) Top to be fabricated from 14 gauge stainless steel with square turndown on all sides and corners fully welded, ground, and polished with #4 finish. Provide with six inch stainless steel adjustable legs. Body constructed with internal support member fabricated of a minimum of 12 gauge galvaneal channel to securely fasten tray rail support brackets. Internal framing is to be 4-1/2" wide, galvaneal channel, shall be mounted vertically on front and rear surfaces and across the interior bottom to form a "U" shaped channel frame. "U" frame mounted at leg attachment location. "U" channel to be 3-1/2" – 4-1/2" wide on operators side. Exterior 20 gauge stainless steel channel mounted between bottom of fiberglass body and legs to provide maximum stress relief.</p> <p>(See Attachment A)</p> <p>Open under storage to be lined with 18 gauge stainless steel with <u>coved vertical and horizontal corners</u>. An intermediate shelf shall have the rear and ends turned up and secured to interior liner.</p> <p>Warranty: Two year manufacturer’s warranty, all parts and labor must be included in the unit price.</p> <p>Approved Brands: Colorpoint Model 60-ST, Delfield Model KC-60-NU-MB or other brands meeting bid specifications</p> <p>Brand Offered: _____</p> <p>Model Offered: _____</p> <p>Warranty Period: _____</p> <p>Delivery (days ARO): _____</p>		

VENDOR NAME: _____
BNG

The School Board of Broward County, Florida
CAFETERIA EQUIPMENT

SECTION 5, BID SUMMARY SHEET (Continued)

		<u>UNIT PRICE</u>	<u>TOTAL COST</u>
ITEM 31:	<u>(TO BE AWARDED AS A GROUP) – Continued</u>		
P.	10 each	\$ _____	/ea \$ _____
	SAP #6001158		
	TABLE, SOLID TOP WITH OPEN BASE – 66” (SERVING LINE)		
	Body to be seamless mold fiberglass with smooth exterior surfaces and rounded corners <u>or</u> 18-8 type 304 stainless steel with smooth exterior surfaces and rounded corners. All fiberglass to be flame retardant per specifications ASTM E-162. To be 28" - 30" wide x 66" long and available in 34", 35", and 36" heights. Body constructed to accommodate tray rail at heights of 32", 33", and 34". (Bid does not include tray rail.) Top to be fabricated from 14 gauge stainless steel with square turndown on all sides and corners fully welded, ground, and polished with #4 finish. Provide with six inch stainless steel adjustable legs. Body constructed with internal support member fabricated of a minimum of 12 gauge galvaneal channel to securely fasten tray rail support brackets. Internal framing is to be 4-1/2" wide, galvaneal channel, shall be mounted vertically on front and rear surfaces and across the interior bottom to form a "U" shaped channel frame. "U" frame mounted at leg attachment location. "U" channel to be 3-1/2" – 4-1/2" wide on operators side. Exterior 20 gauge stainless steel channel mounted between bottom of fiberglass body and legs to provide maximum stress relief. (See Attachment A)		
	Open under storage to be lined with 18 gauge stainless steel with <u>coved vertical and horizontal corners</u> . An intermediate shelf shall have the rear and ends turned up and secured to interior liner.		
	Warranty: Two year manufacturer’s warranty, all parts and labor must be included in the unit price.		
	Approved Brands: Colorpoint Model 66-ST, Delfield Model KC-60-NU-MB or other brands meeting bid specifications		
	Brand Offered: _____		
	Model Offered: _____		
	Warranty Period: _____		
	Delivery (days ARO): _____		

VENDOR NAME: _____
BNG

The School Board of Broward County, Florida
CAFETERIA EQUIPMENT

SECTION 5, BID SUMMARY SHEET (Continued)

		<u>UNIT PRICE</u>		<u>TOTAL COST</u>
ITEM 31:	<u>(TO BE AWARDED AS A GROUP) – Continued</u>			
Q.	5 each			
	SAP #6001121	\$ _____	/ea	\$ _____
	TABLE, SOLID TOP WITH OPEN BASE – 74” (SERVING LINE)			
	Body to be seamless mold fiberglass with smooth exterior surfaces and rounded corners <u>or</u> 18-8 type 304 stainless steel with smooth exterior surfaces and rounded corners. All fiberglass to be flame retardant per specifications ASTM E-162. To be 28" - 30" wide x 74" long and available in 34", 35", and 36" heights. Body constructed to accommodate tray rail at heights of 32", 33", and 34". (Bid does not include tray rail.) Top to be fabricated from 14 gauge stainless steel with square turndown on all sides and corners fully welded, ground, and polished with #4 finish. Provide with six inch stainless steel adjustable legs. Body constructed with internal support member fabricated of a minimum of 12 gauge galvaneal channel to securely fasten tray rail support brackets. Internal framing is to be 4-1/2" wide, galvaneal channel, shall be mounted vertically on front and rear surfaces and across the interior bottom to form a "U" shaped channel frame. "U" frame mounted at leg attachment location. "U" channel to be 3-1/2" – 4-1/2" wide on operators side. Exterior 20 gauge stainless steel channel mounted between bottom of fiberglass body and legs to provide maximum stress relief. (See Attachment A)			
	Open under storage to be lined with 18 gauge stainless steel with <u>coved vertical and horizontal corners</u> . An intermediate shelf shall have the rear and ends turned up and secured to interior liner.			
	Warranty: Two year manufacturer’s warranty, all parts and labor must be included in the unit price.			
	Approved Brands: Colorpoint Model 74-ST, Delfield Model KC-74-NU-MB or other brands meeting bid specifications			
	Brand Offered: _____			
	Model Offered: _____			
	Warranty Period: _____			
	Delivery (days ARO): _____			

VENDOR NAME: _____
BNG

The School Board of Broward County, Florida
CAFETERIA EQUIPMENT

SECTION 5, BID SUMMARY SHEET (Continued)

		<u>UNIT PRICE</u>	<u>TOTAL COST</u>
ITEM 31:	<u>(TO BE AWARDED AS A GROUP) - Continued</u>		
R.	6 each	\$ _____	/ea \$ _____
	<p>SAP #6000112 SLIDE, SOLID TRAY – 28” 14 Gauge stainless steel with three inverted "V" ridges on surface. Ends and side turned down square with all corners fully welded, ground, and polished. Support brackets to be stainless steel. Tray slide bracket mounted through fiberglass body and secures to vertical section of internal "U" frame. Brackets must have adjustment screw to allow for proper alignment of tray slide front edge to maintain continuity of tray slide system (See Attachment B). Manufacturer's standard warranty will apply. Approved Brands: Colorpoint Model Option A 28”, Delfield Model A-28 or other brands meeting bid specifications</p> <p>Brand Offered: _____ Model Offered: _____ Warranty Period: _____ Delivery (days ARO): _____</p>		
S.	10 each	\$ _____	/ea \$ _____
	<p>SAP #6001157 SLIDE, SOLID TRAY – 30” 14 Gauge stainless steel with three inverted "V" ridges on surface. Ends and side turned down square with all corners fully welded, ground, and polished. Support brackets for tray rail stainless steel. Tray slide bracket mounted through fiberglass body and secures to vertical section of internal "U" frame. Brackets must have adjustment screw to allow for proper alignment of tray slide front edge to maintain continuity of tray slide system. (See Attachment B) Manufacturer's standard warranty will apply. Approved Brands: Colorpoint Model Option A 30”, Delfield Model A-30 or other brands meeting bid specifications</p> <p>Brand Offered: _____ Model Offered: _____ Warranty Period: _____ Delivery (days ARO): _____</p>		

VENDOR NAME: _____
BNG

The School Board of Broward County, Florida
CAFETERIA EQUIPMENT

SECTION 5, BID SUMMARY SHEET (Continued)

		<u>UNIT PRICE</u>	<u>TOTAL COST</u>
ITEM 31: (TO BE AWARDED AS A GROUP) - Continued			
T.	5 each	SAP #6001124 SLIDE, SOLID TRAY – 36” 14 Gauge stainless steel with three inverted "V" ridges on surface. Ends and side turned down square with all corners fully welded, ground, and polished. Support brackets to be stainless steel. Tray slide bracket mounted through fiberglass body and secures to vertical section of internal "U" frame. Brackets must have adjustment screw to allow for proper alignment of tray slide front edge to maintain continuity of tray slide system (See Attachment B). Manufacturer's standard warranty will apply. Approved Brands: Colorpoint Model Option A 36”, Delfield Model A-36 or other brands meeting bid specifications	\$ _____ /ea \$ _____
		Brand Offered: _____	
		Model Offered: _____	
		Warranty Period: _____	
		Delivery (days ARO): _____	
U.	10 each	SAP #6001150 SLIDE, SOLID TRAY – 42” 14 Gauge stainless steel with three inverted "V" ridges on surface. Ends and side turned down square with all corners fully welded, ground, and polished. Support brackets for tray rail stainless steel. Tray slide bracket mounted through fiberglass body and secures to vertical section of internal "U" frame. Brackets must have adjustment screw to allow for proper alignment of tray slide front edge to maintain continuity of tray slide system. (See Attachment B) Manufacturer's standard warranty will apply. Approved Brands: Colorpoint Model Option A 42”, Delfield Model A-42 or other brands meeting bid specifications	\$ _____ /ea \$ _____
		Brand Offered: _____	
		Model Offered: _____	
		Warranty Period: _____	
		Delivery (days ARO): _____	

VENDOR NAME: _____
BNG

The School Board of Broward County, Florida
CAFETERIA EQUIPMENT

SECTION 5, BID SUMMARY SHEET (Continued)

		<u>UNIT PRICE</u>	<u>TOTAL COST</u>	
ITEM 31: (TO BE AWARDED AS A GROUP) - Continued				
V.	20 each	SAP #6000101 SLIDE, SOLID TRAY – 50” 14 Gauge stainless steel with three inverted "V" ridges on surface. Ends and side turned down square with all corners fully welded, ground, and polished. Support brackets to be stainless steel. Tray slide bracket mounted through fiberglass body and secures to vertical section of internal "U" frame. Brackets must have adjustment screw to allow for proper alignment of tray slide front edge to maintain continuity of tray slide system (See Attachment B). Manufacturer's standard warranty will apply. Approved Brands: Colorpoint Model Option A 50”, Delfield Model A-50 or other brands meeting bid specifications	\$ _____	/ea \$ _____
		Brand Offered: _____		
		Model Offered: _____		
		Warranty Period: _____		
		Delivery (days ARO): _____		
W.	20 each	SAP #6000102 SLIDE, SOLID TRAY – 60” 14 Gauge stainless steel with three inverted "V" ridges on surface. Ends and side turned down square with all corners fully welded, ground, and polished. Support brackets for tray rail stainless steel. Tray slide bracket mounted through fiberglass body and secures to vertical section of internal "U" frame. Brackets must have adjustment screw to allow for proper alignment of tray slide front edge to maintain continuity of tray slide system. (See Attachment B) Manufacturer's standard warranty will apply. Approved Brands: Colorpoint Model Option A 60”, Delfield Model A-60 or other brands meeting bid specifications	\$ _____	/ea \$ _____
		Brand Offered: _____		
		Model Offered: _____		
		Warranty Period: _____		
		Delivery (days ARO): _____		

VENDOR NAME: _____
BNG

The School Board of Broward County, Florida
CAFETERIA EQUIPMENT

SECTION 5, BID SUMMARY SHEET (Continued)

		<u>UNIT PRICE</u>	<u>TOTAL COST</u>
ITEM 31: (TO BE AWARDED AS A GROUP) - Continued			
X.	20 each	SAP #6001151 SLIDE, SOLID TRAY – 66” 14 Gauge stainless steel with three inverted "V" ridges on surface. Ends and side turned down square with all corners fully welded, ground, and polished. Support brackets to be stainless steel. Tray slide bracket mounted through fiberglass body and secures to vertical section of internal "U" frame. Brackets must have adjustment screw to allow for proper alignment of tray slide front edge to maintain continuity of tray slide system (See Attachment B). Manufacturer's standard warranty will apply. Approved Brands: Colorpoint Model Option A 66”, Delfield Model A-66 or other brands meeting bid specifications Brand Offered: _____ Model Offered: _____ Warranty Period: _____ Delivery (days ARO): _____	\$ _____ /ea \$ _____
Y.	10 each	SAP #6000102 SLIDE, SOLID TRAY – 74” 14 Gauge stainless steel with three inverted "V" ridges on surface. Ends and side turned down square with all corners fully welded, ground, and polished. Support brackets for tray rail stainless steel. Tray slide bracket mounted through fiberglass body and secures to vertical section of internal "U" frame. Brackets must have adjustment screw to allow for proper alignment of tray slide front edge to maintain continuity of tray slide system. (See Attachment B) Manufacturer's standard warranty will apply. Approved Brands: Colorpoint Model Option A 74”, Delfield Model A-74 or other brands meeting bid specifications Brand Offered: _____ Model Offered: _____ Warranty Period: _____ Delivery (days ARO): _____	\$ _____ /ea \$ _____

VENDOR NAME: _____
BNG

The School Board of Broward County, Florida
CAFETERIA EQUIPMENT

SECTION 5, BID SUMMARY SHEET (Continued)

		<u>UNIT PRICE</u>	<u>TOTAL COST</u>
ITEM 31: (TO BE AWARDED AS A GROUP) - Continued			
Z.	20 each	SAP #6000116	\$ _____ /ea \$ _____
		BOARD, CUTTING – 50” (SERVING LINE)	
		Constructed of 14 gauge stainless steel, eight inch wide with edges turned down square on all corners fully welded, ground, and polished. Complete with stainless steel fold down bracket. Tray slide bracket mounted through fiberglass body and secures to vertical section of internal “U” frame. Brackets must have adjustment screw to allow for proper alignment of tray slide front edge to maintain continuity of tray slide system. (See Attachment B) Manufacturer’s standard warranty will apply.	
		Approved Brands: Colorpoint Model Option D50”, Delfield Model E-50 or other brands meeting bid specifications	
		Brand Offered: _____	
		Model Offered: _____	
		Warranty Period: _____	
		Delivery (days ARO): _____	
AA.	70 each	SAP #6001125	\$ _____ /ea \$ _____
		BOARD, CUTTING – 60” (SERVING LINE)	
		Constructed of 14 gauge stainless steel, eight inch wide with edges turned down square on all corners fully welded, ground, and polished. Complete with stainless steel fold down bracket. Tray slide bracket mounted through fiberglass body and secures to vertical section of internal “U” frame. Brackets must have adjustment screw to allow for proper alignment of tray slide front edge to maintain continuity of tray slide system. (See Attachment B) Manufacturer’s standard warranty will apply.	
		Approved Brands: Colorpoint Model Option D60”, Delfield Model E-60 or other brands meeting bid specifications	
		Brand Offered: _____	
		Model Offered: _____	
		Warranty Period: _____	
		Delivery (days ARO): _____	

VENDOR NAME: _____
BNG

The School Board of Broward County, Florida
CAFETERIA EQUIPMENT

SECTION 5, BID SUMMARY SHEET (Continued)

		<u>UNIT PRICE</u>	<u>TOTAL COST</u>
ITEM 31:	<u>(TO BE AWARDED AS A GROUP) – Continued</u>		
BB.	12 each		
	SAP #6001126	\$ _____	/ea \$ _____
	BOARD, CUTTING – 74” (SERVING LINE)		
	Constructed of 14 gauge stainless steel, eight inch wide with edges turned down square on all corners fully welded, ground, and polished. Complete with stainless steel fold down bracket. Tray slide bracket mounted through fiberglass body and secures to vertical section of internal “U” frame. Brackets must have adjustment screw to allow for proper alignment of tray slide front edge to maintain continuity of tray slide system. (See Attachment B) Manufacturer’s standard warranty will apply.		
	Approved Brands: Colorpoint Model Option D74”, Delfield Model E-74 or other brands meeting bid specifications		
	Brand Offered: _____		
	Model Offered: _____		
	Warranty Period: _____		
	Delivery (days ARO): _____		
CC.	10 each		
	SAP #6001152	\$ _____	/ea \$ _____
	PROTECTOR, SLOPED FRONT FOOD – 50” (SERVING LINE)		
	Shall have an 18 gauge stainless steel top serving shelf with all edges turned down square and all corners fully welded, ground, and polished. Ends sloped front glass to be 1/4" polished plate glass with one inch bottom clearance. All glass to be bound in stainless steel channel to prevent chipping. Manufacturer’s standard warranty will apply.		
	Approved Brands: Colorpoint Option G 50”, Delfield G-50 or other brands meeting bid specifications		
	Brand Offered: _____		
	Model Offered: _____		
	Warranty Period: _____		
	Delivery (days ARO): _____		
DD.	20 each		
	SAP #6001131	\$ _____	/ea \$ _____
	PROTECTOR, SLOPED FRONT FOOD – 60” (SERVING LINE)		
	Shall have an 18 gauge stainless steel top serving shelf with all edges turned down square and all corners fully welded, ground, and polished. Ends sloped front glass to be 1/4" polished plate glass with one inch bottom clearance. All glass to be bound in stainless steel channel to prevent chipping. Manufacturer’s standard warranty will apply.		
	Approved Brands: Colorpoint Option G 60”, Delfield G-60 or other brands meeting bid specifications		
	Brand Offered: _____		
	Model Offered: _____		
	Warranty Period: _____		
	Delivery (days ARO): _____		

VENDOR NAME: _____
BNG

The School Board of Broward County, Florida
CAFETERIA EQUIPMENT

SECTION 5, BID SUMMARY SHEET (Continued)

		<u>UNIT PRICE</u>	<u>TOTAL COST</u>
ITEM 31: (TO BE AWARDED AS A GROUP) - Continued			
EE.	3 each	SAP #6001132	\$ _____ /ea \$ _____
		PROTECTOR, SLOPED FRONT FOOD – 74” (SERVING LINE)	
		Shall have an 18 gauge stainless steel top serving shelf with all edges turned down square and all corners fully welded, ground, and polished. Ends sloped front glass to be 1/4" polished plate glass with one inch bottom clearance. All glass to be bound in stainless steel channel to prevent chipping. Manufacturer’s standard warranty will apply.	
		Approved Brands: Colorpoint Option G 74", Delfield G-74 or other brands meeting bid specifications	
		Brand Offered: _____	
		Model Offered: _____	
		Warranty Period: _____	
		Delivery (days ARO): _____	
FF.	5 each	SAP #6001153	\$ _____ /ea \$ _____
		PROTECTOR, SINGLE SERVICE BUFFET, 30” (SERVING LINE)	
		Shall have a Plexiglas sneeze guard along one side with Plexiglas enclosures. A removable top cap shelf of 16 gauge stainless steel with sides turned down square and all corners fully welded, ground, and polished. Unit to be mounted on one inch stainless steel tubular supports. Shield to have adjustable height from five inch opening to eight inch opening in increments of one inch without the use of tools. Manufacturer’s standard warranty will apply.	
		Approved Brands: Colorpoint Option M 30", Delfield KS-28 or other brands meeting bid specifications	
		Brand Offered: _____	
		Model Offered: _____	
		Warranty Period: _____	
		Delivery (days ARO): _____	
GG.	2 each	SAP #6001154	\$ _____ /ea \$ _____
		PROTECTOR, SINGLE SERVICE BUFFET, 36” (SERVING LINE)	
		Shall have a Plexiglas sneeze guard along one side with Plexiglas enclosures. A removable top cap shelf of 16 gauge stainless steel with sides turned down square and all corners fully welded, ground, and polished. Unit to be mounted on one inch stainless steel tubular supports. Shield to have adjustable height from five inch opening to eight inch opening in increments of one inch without the use of tools. Manufacturer’s standard warranty will apply.	
		Approved Brands: Colorpoint Option M 36", Delfield KS-36 or other brands meeting bid specifications	
		Brand Offered: _____	
		Model Offered: _____	
		Warranty Period: _____	
		Delivery (days ARO): _____	

VENDOR NAME: _____
BNG

The School Board of Broward County, Florida
CAFETERIA EQUIPMENT

SECTION 5, BID SUMMARY SHEET (Continued)

		<u>UNIT PRICE</u>	<u>TOTAL COST</u>
ITEM 31: (TO BE AWARDED AS A GROUP) - Continued			
HH.	5 each	SAP #6001133 PROTECTOR, SINGLE SERVICE BUFFET, 42" (SERVING LINE) Shall have a Plexiglas sneeze guard along one side with Plexiglas enclosures. A removable top cap shelf of 16 gauge stainless steel with sides turned down square and all corners fully welded, ground, and polished. Unit to be mounted on one inch stainless steel tubular supports. Shield to have adjustable height from five inch opening to eight inch opening in increments of one inch without the use of tools. Manufacturer's standard warranty will apply. Approved Brands: Colorpoint Option M 42", Delfield KS-42 or other brands meeting bid specifications Brand Offered: _____ Model Offered: _____ Warranty Period: _____ Delivery (days ARO): _____	\$ _____ /ea \$ _____
II.	15 each	SAP #6001134 PROTECTOR, SINGLE SERVICE BUFFET, 50" (SERVING LINE) Shall have a Plexiglas sneeze guard along one side with Plexiglas enclosures. A removable top cap shelf of 16 gauge stainless steel with sides turned down square and all corners fully welded, ground, and polished. Unit to be mounted on one inch stainless steel tubular supports. Shield to have adjustable height from five inch opening to eight inch opening in increments of one inch without the use of tools. Manufacturer's standard warranty will apply. Approved Brands: Colorpoint Option M 50", Delfield KS-50 or other brands meeting bid specifications Brand Offered: _____ Model Offered: _____ Warranty Period: _____ Delivery (days ARO): _____	\$ _____ /ea \$ _____
JJ.	20 each	SAP #6001135 PROTECTOR, SINGLE SERVICE BUFFET, 60" (SERVING LINE) Shall have a Plexiglas sneeze guard along one side with Plexiglas enclosures. A removable top cap shelf of 16 gauge stainless steel with sides turned down square and all corners fully welded, ground, and polished. Unit to be mounted on one inch stainless steel tubular supports. Shield to have adjustable height from five inch opening to eight inch opening in increments of one inch without the use of tools. Manufacturer's standard warranty will apply. Approved Brands: Colorpoint Option M 36", Delfield KS-60 or other brands meeting bid specifications Brand Offered: _____ Model Offered: _____ Warranty Period: _____ Delivery (days ARO): _____	\$ _____ /ea \$ _____

VENDOR NAME: _____
BNG

The School Board of Broward County, Florida
CAFETERIA EQUIPMENT

SECTION 5, BID SUMMARY SHEET (Continued)

		<u>UNIT PRICE</u>	<u>TOTAL COST</u>
ITEM 31: (TO BE AWARDED AS A GROUP) - Continued			
KK.	10 each	SAP #6001155 PROTECTOR, SINGLE SERVICE BUFFET, 66" (SERVING LINE) Shall have a Plexiglas sneeze guard along one side with Plexiglas enclosures. A removable top cap shelf of 16 gauge stainless steel with sides turned down square and all corners fully welded, ground, and polished. Unit to be mounted on one inch stainless steel tubular supports. Shield to have adjustable height from five inch opening to eight inch opening in increments of one inch without the use of tools. Manufacturer's standard warranty will apply. Approved Brands: Colorpoint Option M 66", Delfield KS-66 or other brands meeting bid specifications Brand Offered: _____ Model Offered: _____ Warranty Period: _____ Delivery (days ARO): _____	\$ _____ /ea \$ _____
LL.	5 each	SAP #6001136 PROTECTOR, SINGLE SERVICE BUFFET, 74" (SERVING LINE) Shall have a Plexiglas sneeze guard along one side with Plexiglas enclosures. A removable top cap shelf of 16 gauge stainless steel with sides turned down square and all corners fully welded, ground, and polished. Unit to be mounted on one inch stainless steel tubular supports. Shield to have adjustable height from five inch opening to eight inch opening in increments of one inch without the use of tools. Manufacturer's standard warranty will apply. Approved Brands: Colorpoint Option M74 ", Delfield KS-74 or other brands meeting bid specifications Brand Offered: _____ Model Offered: _____ Warranty Period: _____ Delivery (days ARO): _____	\$ _____ /ea \$ _____
MM.	10 each	SAP #6001156 DISPLAY, TWO TIER – 30" (SERVING LINE) With sloped front stand shall have 1-1/4" square stainless steel tubing with stainless steel cap and base. Shelves to be 1/4" polished plate glass resting on a horizontal stainless steel framework welded to the uprights. The display sneeze guard to be mounted on adjustable stainless steel brackets. Manufacturer's standard warranty will apply. Approved Brands: Colorpoint Option I 30", Delfield H-28 or other brands meeting bid specifications Brand Offered: _____ Model Offered: _____ Warranty Period: _____ Delivery (days ARO): _____	\$ _____ /ea \$ _____

VENDOR NAME: _____
BNG

The School Board of Broward County, Florida
CAFETERIA EQUIPMENT

SECTION 5, BID SUMMARY SHEET (Continued)

		<u>UNIT PRICE</u>	<u>TOTAL COST</u>
ITEM 31: (TO BE AWARDED AS A GROUP) - Continued			
NN.	15 each	SAP #6001127	\$ _____ /ea \$ _____
		DISPLAY, TWO TIER – 36" (SERVING LINE)	
		With sloped front stand shall have 1-1/4" square stainless steel tubing with stainless steel cap and base. Shelves to be 1/4" polished plate glass resting on a horizontal stainless steel framework welded to the uprights. The display sneeze guard to be mounted on adjustable stainless steel brackets. Manufacturer's standard warranty will apply.	
		Approved Brands: Colorpoint Option I 36", Delfield H-36 or other brands meeting bid specifications	
		Brand Offered: _____	
		Model Offered: _____	
		Warranty Period: _____	
		Delivery (days ARO): _____	
OO.	5 each	SAP #6001147	\$ _____ /ea \$ _____
		DISPLAY, TWO TIER – 42" (SERVING LINE)	
		With sloped front stand shall have 1-1/4" square stainless steel tubing with stainless steel cap and base. Shelves to be 1/4" polished plate glass resting on a horizontal stainless steel framework welded to the uprights. The display sneeze guard to be mounted on adjustable stainless steel brackets. Manufacturer's standard warranty will apply.	
		Approved Brands: Colorpoint Option I 42", Delfield H-42 or other brands meeting bid specifications	
		Brand Offered: _____	
		Model Offered: _____	
		Warranty Period: _____	
		Delivery (days ARO): _____	
PP.	20 each	SAP #6000104	\$ _____ /ea \$ _____
		DISPLAY, TWO TIER – 50" (SERVING LINE)	
		With sloped front stand shall have 1-1/4" square stainless steel tubing with stainless steel cap and base. Shelves to be 1/4" polished plate glass resting on a horizontal stainless steel framework welded to the uprights. The display sneeze guard to be mounted on adjustable stainless steel brackets. Manufacturer's standard warranty will apply.	
		Approved Brands: Colorpoint Option I 50", Delfield H-50 or other brands meeting bid specifications	
		Brand Offered: _____	
		Model Offered: _____	
		Warranty Period: _____	
		Delivery (days ARO): _____	

VENDOR NAME: _____
BNG

The School Board of Broward County, Florida
CAFETERIA EQUIPMENT

SECTION 5, BID SUMMARY SHEET (Continued)

		<u>UNIT PRICE</u>	<u>TOTAL COST</u>
ITEM 31:	<u>(TO BE AWARDED AS A GROUP) - Continued</u>		
QQ. 20 each	SAP #6000105 DISPLAY, TWO TIER – 60" (SERVING LINE) With sloped front stand shall have 1-1/4" square stainless steel tubing with stainless steel cap and base. Shelves to be 1/4" polished plate glass resting on a horizontal stainless steel framework welded to the uprights. The display sneeze guard to be mounted on adjustable stainless steel brackets. Manufacturer's standard warranty will apply. Approved Brands: Colorpoint Option I 60", Delfield H-60 or other brands meeting bid specifications Brand Offered: _____ Model Offered: _____ Warranty Period: _____ Delivery (days ARO): _____	\$ _____	/ea \$ _____
RR. 10 each	SAP #6001159 DISPLAY, TWO TIER – 66" (SERVING LINE) With sloped front stand shall have 1-1/4" square stainless steel tubing with stainless steel cap and base. Shelves to be 1/4" polished plate glass resting on a horizontal stainless steel framework welded to the uprights. The display sneeze guard to be mounted on adjustable stainless steel brackets. Manufacturer's standard warranty will apply. Approved Brands: Colorpoint Option I 66", Delfield H-60 MOD or other brands meeting bid specifications Brand Offered: _____ Model Offered: _____ Warranty Period: _____ Delivery (days ARO): _____	\$ _____	/ea \$ _____
SS. 15 each	SAP #6000106 DISPLAY, TWO TIER – 74" (SERVING LINE) With sloped front stand shall have 1-1/4" square stainless steel tubing with stainless steel cap and base. Shelves to be 1/4" polished plate glass resting on a horizontal stainless steel framework welded to the uprights. The display sneeze guard to be mounted on adjustable stainless steel brackets. Manufacturer's standard warranty will apply. Approved Brands: Colorpoint Option I 74", Delfield H-74 or other brands meeting bid specifications Brand Offered: _____ Model Offered: _____ Warranty Period: _____ Delivery (days ARO): _____	\$ _____	/ea \$ _____

VENDOR NAME: _____
BNG

The School Board of Broward County, Florida
CAFETERIA EQUIPMENT

SECTION 5, BID SUMMARY SHEET (Continued)

		<u>UNIT PRICE</u>	<u>TOTAL COST</u>
ITEM 31:	<u>(TO BE AWARDED AS A GROUP) - Continued</u>		
TT. 3 each	SAP #6001164 STAND, THREE TIER DISPLAY 28-30" (SERVING LINE) With sloped front stand shall have 1-1/4" square stainless steel tubing with stainless steel cap and base. Shelves to be 1/4" polished plate glass resting on a horizontal stainless steel framework welded to the uprights. The display sneeze guard to be mounted on adjustable stainless steel brackets. Manufacturer's standard warranty will apply. Approved Brands: Colorpoint Option K 30", Delfield Model I-28 or other brands meeting bid specifications Brand Offered: _____ Model Offered: _____ Warranty Period: _____ Delivery (days ARO): _____	\$ _____	/ea \$ _____
UU. 2 each	SAP #6001137 STAND, THREE TIER DISPLAY 36" (SERVING LINE) With sloped front stand shall have 1-1/4" square stainless steel tubing with stainless steel cap and base. Shelves to be 1/4" polished plate glass resting on a horizontal stainless steel framework welded to the uprights. The display sneeze guard to be mounted on adjustable stainless steel brackets. Manufacturer's standard warranty will apply. Approved Brands: Colorpoint Option K 36", Delfield Model I-36 or other brands meeting bid specifications Brand Offered: _____ Model Offered: _____ Warranty Period: _____ Delivery (days ARO): _____	\$ _____	/ea \$ _____
VV. 2 each	SAP #6001160 STAND, THREE TIER DISPLAY 42" (SERVING LINE) With sloped front stand shall have 1-1/4" square stainless steel tubing with stainless steel cap and base. Shelves to be 1/4" polished plate glass resting on a horizontal stainless steel framework welded to the uprights. The display sneeze guard to be mounted on adjustable stainless steel brackets. Manufacturer's standard warranty will apply. Approved Brands: Colorpoint Option K 42", Delfield Model I-42 or other brands meeting bid specifications Brand Offered: _____ Model Offered: _____ Warranty Period: _____ Delivery (days ARO): _____	\$ _____	/ea \$ _____

VENDOR NAME: _____
BNG

The School Board of Broward County, Florida
CAFETERIA EQUIPMENT

SECTION 5, BID SUMMARY SHEET (Continued)

		<u>UNIT PRICE</u>		<u>TOTAL COST</u>
ITEM 31:	<u>(TO BE AWARDED AS A GROUP) - Continued</u>			
WW. 3 each	SAP #6001138 STAND, THREE TIER DISPLAY 50" (SERVING LINE) With sloped front stand shall have 1-1/4" square stainless steel tubing with stainless steel cap and base. Shelves to be 1/4" polished plate glass resting on a horizontal stainless steel framework welded to the uprights. The display sneeze guard to be mounted on adjustable stainless steel brackets. Manufacturer's standard warranty will apply. Approved Brands: Colorpoint Option K 50", Delfield Model I-50 or other brands meeting bid specifications Brand Offered: _____ Model Offered: _____ Warranty Period: _____ Delivery (days ARO): _____	\$ _____	/ea	\$ _____
XX. 5 each	SAP #6001139 STAND, THREE TIER DISPLAY 60" (SERVING LINE) With sloped front stand shall have 1-1/4" square stainless steel tubing with stainless steel cap and base. Shelves to be 1/4" polished plate glass resting on a horizontal stainless steel framework welded to the uprights. The display sneeze guard to be mounted on adjustable stainless steel brackets. Manufacturer's standard warranty will apply. Approved Brands: Colorpoint Option K 60", Delfield Model I-60 or other brands meeting bid specifications Brand Offered: _____ Model Offered: _____ Warranty Period: _____ Delivery (days ARO): _____	\$ _____	/ea	\$ _____
YY. 2 each	SAP #6001161 STAND, THREE TIER DISPLAY 66" (SERVING LINE) With sloped front stand shall have 1-1/4" square stainless steel tubing with stainless steel cap and base. Shelves to be 1/4" polished plate glass resting on a horizontal stainless steel framework welded to the uprights. The display sneeze guard to be mounted on adjustable stainless steel brackets. Manufacturer's standard warranty will apply. Approved Brands: Colorpoint Option K 66", Delfield Model I-66-MOD or other brands meeting bid specifications Brand Offered: _____ Model Offered: _____ Warranty Period: _____ Delivery (days ARO): _____	\$ _____	/ea	\$ _____

VENDOR NAME: _____
BNG

The School Board of Broward County, Florida
CAFETERIA EQUIPMENT

SECTION 5, BID SUMMARY SHEET (Continued)

		<u>UNIT PRICE</u>	<u>TOTAL COST</u>
ITEM 31: (TO BE AWARDED AS A GROUP) - Continued			
ZZ.	3 each	SAP #6001140	\$ _____ /ea \$ _____
STAND, THREE TIER DISPLAY 74" (SERVING LINE) With sloped front stand shall have 1-1/4" square stainless steel tubing with stainless steel cap and base. Shelves to be 1/4" polished plate glass resting on a horizontal stainless steel framework welded to the uprights. The display sneeze guard to be mounted on adjustable stainless steel brackets. Manufacturer's standard warranty will apply. Approved Brands: Colorpoint Option K 74", Delfield Model I-74 or other brands meeting bid specifications			
Brand Offered: _____ Model Offered: _____ Warranty Period: _____ Delivery (days ARO): _____			
AAA.	50 each	SAP #6000108	\$ _____ /ea \$ _____
LOCKS, LINE UP – SERVING LINE To be barrel bolt and key slot design with cam locking action. Locks to be placed on opposing corners for maximum versatility. Manufacturer's standard warranty will apply. Approved Brands: Colorpoint Option AA, Delfield "F" or other brands meeting bid specifications			
Brand Offered: _____ Model Offered: _____ Warranty Period: _____ Delivery (days ARO): _____			
BBB.	2 each	SAP #6001129	\$ _____ /ea \$ _____
OUTLET, CONVENIENCE – SERVING LINE Flush mount type, to be 120 VAC prewired and fused as required. Receptacle to be recessed in stainless steel housing on a body surface. Manufacturer's standard warranty will apply. Approved Brands: Colorpoint Option, Delfield "Q" or other brands meeting bid specifications			
Brand Offered: _____ Model Offered: _____ Warranty Period: _____ Delivery (days ARO): _____			

VENDOR NAME: _____
BNG

The School Board of Broward County, Florida
CAFETERIA EQUIPMENT

SECTION 5, BID SUMMARY SHEET (Continued)

		<u>UNIT PRICE</u>		<u>TOTAL COST</u>
ITEM 31:	<u>(TO BE AWARDED AS A GROUP) - Continued</u>			
CCC. 3 each	SAP #6001130 SHELF, END DROP – SERVING LINE To be 16 gauge stainless steel 30" x 12" wide with edges turned down square and all corners fully welded, ground, and polished. Support brackets to be stainless steel. Manufacturer's standard warranty will apply. Approved Brands: Colorpoint Option FF, Delfield "U" or other brands meeting bid specifications Brand Offered: _____ Model Offered: _____ Warranty Period: _____ Delivery (days ARO): _____	\$ _____	/ea	\$ _____
DDD. 5 each	SAP #6001128 STRIP, HEAT LAMP – 60" (SERVING LINE) With lights shall have food safe incandescent lamps built into the heat lamp housing and wired to a separate ON/OFF switch as required. This heat lamp is to be mounted to the top tier of Option I. Lamp and light to be Hatco #GRAL or other brands meeting bid specifications. Manufacturer's standard warranty will apply. Approved Brands: Colorpoint Option U 60", Delfield M-60 or other brands meeting bid specifications Brand Offered: _____ Model Offered: _____ Warranty Period: _____ Delivery (days ARO): _____	\$ _____	/ea	\$ _____
EEE. 20 each	SAP #6000107 STRIP, HEAT LAMP – 74" (SERVING LINE) With lights shall have food safe incandescent lamps built into the heat lamp housing and wired to a separate ON/OFF switch as required. This heat lamp is to be mounted to the top tier of Option I. Lamp and light to be Hatco #GRAL or other brands meeting bid specifications. Manufacturer's standard warranty will apply. Approved Brands: Colorpoint Option U 74", Delfield M-74 or other brands meeting bid specifications Brand Offered: _____ Model Offered: _____ Warranty Period: _____ Delivery (days ARO): _____	\$ _____	/ea	\$ _____

VENDOR NAME: _____
BNG

The School Board of Broward County, Florida
CAFETERIA EQUIPMENT

SECTION 5, BID SUMMARY SHEET (Continued)

		<u>UNIT PRICE</u>	<u>TOTAL COST</u>
ITEM 31:	<u>(TO BE AWARDED AS A GROUP) - Continued</u>		
FFF. 3 each	SAP #6001162 BULB, HEAT LAMP – 60” (SERVING LINE) Food safe bullet type to be secured to the underside of the top cap of buffet shields. Bulb holder to have porcelain socket and stainless steel conical bulb protector. Each lamp is individually wired to ON/OFF switch. Complete with four each 40 watt incandescent bulbs. Manufacturer’s standard warranty will apply. Approved Brands: Colorpoint Option T 60”, Delfield MB-4 or other brands meeting bid specifications Brand Offered: _____ Model Offered: _____ Warranty Period: _____ Delivery (days ARO): _____	\$ _____	/ea \$ _____
GGG. 5 each	SAP #6001163 BULB, HEAT LAMP – 74” (SERVING LINE) Food safe bullet type to be secured to the underside of the top cap of buffet shields. Bulb holder to have porcelain socket and stainless steel conical bulb protector. Each lamp is individually wired to ON/OFF switch. Complete with four each 40 watt incandescent bulbs. Manufacturer’s standard warranty will apply. Approved Brands: Colorpoint Option T 74”, Delfield MB-5 or other brands meeting bid specifications Brand Offered: _____ Model Offered: _____ Warranty Period: _____ Delivery (days ARO): _____	\$ _____	/ea \$ _____
HHH. 15 each	SAP #6000118 COLOR, CUSTOM UPGRADE – SERVING LINE Manufacturer’s standard warranty will apply. Approved Brands: Colorpoint Model CC-0001, Delfield Model “Custom Color” or other brands meeting bid specifications Brand Offered: _____ Model Offered: _____ Warranty Period: _____ Delivery (days ARO): _____	\$ _____	/ea \$ _____

VENDOR NAME: _____
BNG

The School Board of Broward County, Florida
CAFETERIA EQUIPMENT

SECTION 5, BID SUMMARY SHEET (Continued)

		<u>UNIT PRICE</u>		<u>TOTAL COST</u>
ITEM 31:	<u>(TO BE AWARDED AS A GROUP) - Continued</u>			
III.	5 each	SAP #6001142	\$ _____	/ea \$ _____
		FRONT, FALSE – 64” (SERVING LINE) Top to be 14 gauge stainless steel with square turndown on all sides and corners fully welded, ground and polished. Top surface to have #4 finish and all edges to have #7 hi-lite finish. The exterior body form shall consist of 14 gauge stainless steel vertical and horizontal angle with all joints fully welded ground and polished making body frame one integral unit. Front panel shall be smooth fiberglass reinforced polyester (F.R.P.). Fiberglass to be flame retardant per ASTM specification E-162 having a flame spread of 25 or less. Rear exterior panel to be 18 gauge stainless steel formed to include end panels. False panel to include line up locks and flanged, adjustable bullet feet. Manufacturer’s standard warranty will apply. Approved Brands: Colorpoint 64" False Front, Delfield 64" False Front or other brands meeting bid specifications		
		Brand Offered: _____ Model Offered: _____ Warranty Period: _____ Delivery (days ARO): _____		

VENDOR NAME: _____
BNG

The School Board of Broward County, Florida
CAFETERIA EQUIPMENT

SECTION 5, BID SUMMARY SHEET (Continued)

		<u>UNIT PRICE</u>		<u>TOTAL COST</u>
ITEM 31:	<u>(TO BE AWARDED AS A GROUP) - Continued</u>			
JJJ. 25 each	SAP #6000110	\$ _____	/ea	\$ _____
	STAND, CASHIER – SERVING LINE			
	Body to be seamless mold fiberglass reinforced polyester (F.R.P.) with smooth exterior surfaces and rounded corners. All fiberglass to be flame retardant per specifications ASTM E-162. To be 28" - 30" wide x 28" long. Top to be fabricated from 14 gauge stainless steel with square turndown on all sides and corners fully welded, ground, and polished with #4 finish. Complete with optional locking cash drawer. Internal framing is to be 4-1/2" wide, galvanneal channel, shall be mounted vertically on front and rear surfaces and across the interior bottom to form a "U" shaped channel frame. "U" frame mounted at leg attachment location. "U" channel to be 3-1/2" – 4-1/2" wide on operators side. Exterior 20 gauge stainless steel channel mounted between bottom of fiberglass body and legs to provide maximum stress relief. (See Attachment A)			
	Unit to have 4" diameter, ball bearing, swivel type casters to be non-marking and with brakes on two of four wheels. Casters mounted with exterior and interior bracing for maximum stress relief. NSF and UL listed.			
	Warranty: Two year warranty, all parts and labor must be included in the unit price.			
	Approved Brands: Colorpoint Model K-28-CSE, Delfield Model KCS-30 or other brands meeting bid specifications			
	Brand Offered: _____			
	Model Offered: _____			
	Warranty Period: _____			
	Delivery (days ARO): _____			

VENDOR NAME: _____
BNG

The School Board of Broward County, Florida
CAFETERIA EQUIPMENT

SECTION 5, BID SUMMARY SHEET (Continued)

		<u>UNIT PRICE</u>		<u>TOTAL COST</u>
ITEM 31:	<u>(TO BE AWARDED AS A GROUP) - Continued</u>			
KKK. 25 each	SAP # _____	\$ _____	/ea	\$ _____
<p>STAND, CASHIER – SERVING LINE Body to be seamless mold fiberglass reinforced polyester (F.R.P.) with smooth exterior surfaces and rounded corners. All fiberglass to be flame retardant per specifications ASTM E-162. To be 28" - 30" wide x 36" long. Top to be fabricated from 14 gauge stainless steel with square turndown on all sides and corners fully welded, ground, and polished with #4 finish. Complete with optional locking cash drawer. Internal framing is to be 4-1/2" wide, galvanneal channel, shall be mounted vertically on front and rear surfaces and across the interior bottom to form a "U" shaped channel frame. "U" frame mounted at leg attachment location. "U" channel to be 3-1/2" – 4-1/2" wide on operators side. Exterior 20 gauge stainless steel channel mounted between bottom of fiberglass body and legs to provide maximum stress relief. (See Attachment A) Unit to have 4" diameter, ball bearing, swivel type casters to be non-marking and with brakes on two of four wheels. Casters mounted with exterior and interior bracing for maximum stress relief. NSF and UL listed. Warranty: Two year warranty, all parts and labor must be included in the unit price. Approved Brands: Colorpoint Model K-36-CSE, Delfield Model KCS-36 or other brands meeting bid specifications</p> <p>Brand Offered: _____ Model Offered: _____ Warranty Period: _____ Delivery (days ARO): _____</p>				

VENDOR NAME: _____
BNG

The School Board of Broward County, Florida
CAFETERIA EQUIPMENT

SECTION 5, BID SUMMARY SHEET (Continued)

		<u>UNIT PRICE</u>		<u>TOTAL COST</u>
ITEM 31:	<u>(TO BE AWARDED AS A GROUP) - Continued</u>			
LLL. 25 each	SAP # _____	\$ _____	/ea	\$ _____
	STAND, CASHIER – SERVING LINE			
	Body to be seamless mold fiberglass reinforced polyester (F.R.P.) with smooth exterior surfaces and rounded corners. All fiberglass to be flame retardant per specifications ASTM E-162. To be 28" - 30" wide x 42" long. Top to be fabricated from 14 gauge stainless steel with square turndown on all sides and corners fully welded, ground, and polished with #4 finish. Complete with optional locking cash drawer. Internal framing is to be 4-1/2" wide, galvanneal channel, shall be mounted vertically on front and rear surfaces and across the interior bottom to form a "U" shaped channel frame. "U" frame mounted at leg attachment location. "U" channel to be 3-1/2" – 4-1/2" wide on operators side. Exterior 20 gauge stainless steel channel mounted between bottom of fiberglass body and legs to provide maximum stress relief. (See Attachment A)			
	Unit to have 4" diameter, ball bearing, swivel type casters to be non-marking and with brakes on two of four wheels. Casters mounted with exterior and interior bracing for maximum stress relief. NSF and UL listed.			
	Warranty: Two year warranty, all parts and labor must be included in the unit price.			
	Approved Brands: Colorpoint Model K-42-CSE, Delfield Model KCS-42 or other brands meeting bid specifications			
	Brand Offered: _____			
	Model Offered: _____			
	Warranty Period: _____			
	Delivery (days ARO): _____			

VENDOR NAME: _____
BNG

The School Board of Broward County, Florida
CAFETERIA EQUIPMENT

SECTION 5, BID SUMMARY SHEET (Continued)

		<u>UNIT PRICE</u>	<u>TOTAL COST</u>
ITEM 31:	<u>(TO BE AWARDED AS A GROUP) - Continued</u>		
MMM. 12 each	SAP # _____ REFRIGERATED COLD TABLE – OPEN BASE – 50-51” Body to be constructed of fiberglass panels with vertical and horizontal stainless steel trim or 18-8 type 304 stainless steel with smooth exterior surfaces and rounded corners. All fiberglass to be flame retardant per specifications ASTM E-162. To be 34" wide x 50" - 51" long and available in 34", 35", and 36" heights. Body constructed to accommodate tray rail at heights of 32", 33", and 34". (Bid does not include tray rail.) Top to be fabricated from 14 gauge stainless steel with square turndown on all sides and corners fully welded, ground, and polished with #4 finish. Body constructed with internal support member fabricated of a minimum of 12 gauge galvaneal channel to securely fasten tray rail support brackets. Provide with 6" stainless steel adjustable legs. Internal framing is to be 4-1/2" wide, galvaneal channel, shall be mounted vertically on front and rear surfaces and across the interior bottom to form a "U" shaped channel frame. "U" frame mounted at leg attachment location. "U" channel to be 3-1/2" – 4-1/2" wide on operators side. Exterior 20 gauge stainless steel channel mounted between bottom of fiberglass body and legs to provide maximum stress relief. (See Attachment A) Mechanical cold pan to be 18 gauge stainless steel fully welded construction with 1/4" coved corners. The cold pan shall be pitched to a 1" drain which is extended to a valve below the base. All cold pans shall be furnished with urethane insulation on bottom and all four sides of pan. The pan shall be fully separated from the counter top by a full perimeter breaker strip. To accommodate a 6" deep full size pan. Temperature is maintained by a static air system utilizing 1/2" copper coils attached to the liner bottom and sides to a level 1" above food pans. To have a fully hermetic condensing unit operating on R-134A refrigerant. Food pans shall be supported by full length removable brackets located 3" below top. To have drain with extension to shut-off valve below base. Open under storage to be lined with 18 gauge stainless steel <u>coved vertical and horizontal corners</u> . With 6" stainless steel adjustable legs. U.L. Listed and N.S.F. Approved. Warranty: Two year manufacturer’s warranty, all parts and labor must be included in the unit price. Approved Brands: Colorpoint Model 50-CFMX, Delfield Model KCSC-50B or other brands meeting bid specifications Brand Offered: _____ Model Offered: _____ Warranty Period: _____ Delivery (days ARO): _____	\$ _____	/ea \$ _____

VENDOR NAME: _____
BNG

The School Board of Broward County, Florida
CAFETERIA EQUIPMENT

SECTION 5, BID SUMMARY SHEET (Continued)

	<u>UNIT PRICE</u>	<u>TOTAL COST</u>
ITEM 31:		
<u>(TO BE AWARDED AS A GROUP) - Continued</u>		
NNN. 12 each	\$ _____	/ea \$ _____
<p>SAP # _____</p> <p>REFRIGERATED COLD TABLE – OPEN BASE – 60-61”</p> <p>Body to be constructed of fiberglass panels with vertical and horizontal stainless steel trim or 18-8 type 304 stainless steel with smooth exterior surfaces and rounded corners. All fiberglass to be flame retardant per specifications ASTM E-162. To be 34" wide x 50" - 51" long and available in 34", 35", and 36" heights. Body constructed to accommodate tray rail at heights of 32", 33", and 34". (Bid does not include tray rail.) Top to be fabricated from 14 gauge stainless steel with square turndown on all sides and corners fully welded, ground, and polished with #4 finish. Body constructed with internal support member fabricated of a minimum of 12 gauge galvaneal channel to securely fasten tray rail support brackets. Provide with 6" stainless steel adjustable legs. Internal framing is to be 4-1/2" wide, galvaneal channel, shall be mounted vertically on front and rear surfaces and across the interior bottom to form a "U" shaped channel frame. "U" frame mounted at leg attachment location. "U" channel to be 3-1/2" – 4-1/2" wide on operators side. Exterior 20 gauge stainless steel channel mounted between bottom of fiberglass body and legs to provide maximum stress relief. (See Attachment A)</p> <p>Mechanical cold pan to be 18 gauge stainless steel fully welded construction with 1/4" coved corners. The cold pan shall be pitched to a 1" drain which is extended to a valve below the base. All cold pans shall be furnished with urethane insulation on bottom and all four sides of pan. The pan shall be fully separated from the counter top by a full perimeter breaker strip. To accommodate a 6" deep full size pan. Temperature is maintained by a static air system utilizing 1/2" copper coils attached to the liner bottom and sides to a level 1" above food pans. To have a fully hermetic condensing unit operating on R-134A refrigerant. Food pans shall be supported by full length removable brackets located 3" below top. To have drain with extension to shut-off valve below base. Open under storage to be lined with 18 gauge stainless steel <u>coved vertical and horizontal corners</u>. With 6" stainless steel adjustable legs. U.L. Listed and N.S.F. Approved. Warranty: Two year manufacturer's warranty, all parts and labor must be included in the unit price.</p> <p>Approved Brands: Colorpoint Model 60-CFMX, Delfield Model KCSC-60 or other brands meeting bid specifications</p> <p>Brand Offered: _____</p> <p>Model Offered: _____</p> <p>Warranty Period: _____</p> <p>Delivery (days ARO): _____</p>		
TOTAL BID ITEM 31 (A – NNN inclusive).....		\$ _____

VENDOR NAME: _____
BNG

The School Board of Broward County, Florida
CAFETERIA EQUIPMENT

SECTION 5, BID SUMMARY SHEET (Continued)

		<u>UNIT PRICE</u>	<u>TOTAL COST</u>
ITEM 32: (TO BE AWARDED AS A GROUP)			
A.	50 each	SAP #6000815	\$ _____ /ea \$ _____
		SCALE, DIGITAL DOUGH – HEAVY DUTY SUBMERSIBLE 10# CAPACITY	
		Self-calibrating, all stainless steel body. NSF approved. Operates on batteries or UL/CE approved AC power supply. Power cord included. With Platform. Water-tight battery compartment. Approx. 6” x 6-3/4” one piece platform with corrosion protection. Weighs in pounds and ounces up to 10 lbs. and oz. increments of .1 oz. to 1/8 oz. Adjustable leveling feet. Warranty: One year, all parts and labor to be included in the unit price.	
		Approved Brand: Edlund “Poseidon” Model WSC-10 with platform or other brands meeting bid specifications	
		Brand Offered: _____	
		Model Offered: _____	
		Warranty Period: _____	
		Delivery (days ARO): _____	
B.	75 each	SAP #6004408	\$ _____ /ea \$ _____
		SCALE, DIGITAL DOUGH – HEAVY DUTY SUBMERSIBLE 20# CAPACITY	
		Self-calibrating, all stainless steel body. NSF approved. Operates on batteries or UL/CE approved AC power supply. Power cord included. To include platform. Water-tight battery compartment. Approx. 7” x 8-3/4” one piece platform with corrosion protection. Weighs in pounds and ounces up to 20 lbs. and oz. increments of .1 oz. to 1/8 oz. Adjustable leveling feet. Warranty: One year, all parts and labor to be included in the unit price.	
		Approved Brand: Edlund “Poseidon” Model WSC-20OP or other brands meeting bid specifications	
		Brand Offered: _____	
		Model Offered: _____	
		Warranty Period: _____	
		Delivery (days ARO): _____	
		TOTAL BID ITEM 32 (A – B inclusive).....	\$ _____

VENDOR NAME: _____
BNG

The School Board of Broward County, Florida
CAFETERIA EQUIPMENT

SECTION 5, BID SUMMARY SHEET (Continued)

		<u>UNIT PRICE</u>	<u>TOTAL COST</u>
ITEM 33:	15 each		
	SAP #6000818		
	SCALE, 25 POUND PORTION	\$ _____	/ea \$ _____
	Constructed of heavy duty stainless steel inside and out to resist rusting. Measures up to 25 pounds in two ounce increments and larger one pound increments (metric not acceptable). Scale must be able to provide fast and accurate readings, and scale must show measurements in both ounces and pounds. Large fixed dial must be recessed with removable lexan face plate, and dial must contain large black numbers on a white surface with colored pointer. Diameter of dial to be approximately 8-1/2". Large stainless steel minimum 7" x 8-3/4" platform. Must have easy-to-turn adjusting but to calibrate scale. Warranty: One year warranty, all parts and labor to be included in the unit price.		
	Approved Brand: Edlund Model RM-25 or other brands meeting bid specifications		

Brand Offered: _____

Model Offered: _____

Warranty Period: _____

Delivery (days ARO): _____

VENDOR NAME: _____

BNG

The School Board of Broward County, Florida
CAFETERIA EQUIPMENT

SECTION 5, BID SUMMARY SHEET (Continued)

		<u>UNIT PRICE</u>	<u>TOTAL COST</u>
<u>ITEM 34:</u>	8 each		
	SAP #6000130		
	SLICER, TWO SPEED AUTOMATIC 12"-13"	\$ _____	/ea \$ _____
	<p>½ HP motor, stainless steel knife. Unit to have completely smooth surface with no cracks or crevices that could harbor food products and no exposed bolt gears or screws. Unit must be NSF approved, U.L. or ETL listed. Microban antimicrobial additive built into the external plastic components to inhibit growth of bacteria and mold. Motor has permanently lubricated ball bearings and is totally enclosed, integral with slicer. Switch shall be moisture protected toggle or touch pad type. Easy to clean, two to four removable parts. Carriage slide rod must be designed to resist rusting and withstand high humidity; electroless nickel coating or equivalent. Stainless steel carriage system tilting and removable without need for tools. Non-removable stainless steel knife ring guard to protect knife during cleaning and operation. No volt interlock release. Top mounted Barazon (or equivalent) knife sharpener that is removable and washable with lifetime guarantee. Knife speed 350-400 RPM. Poly V-Belt or gear driven system, no computers or electronic boards. Electrical 115-120/60/1, maximum 7 amps. Minimum 6 foot, three wire power supply cord and plug. Bid price must include two-year manufacturer's warranty, parts and labor from date of installation. Price to also include: Uncrate, set-in-place and demonstration for each order.</p> <p>Approved Brands: Globe Model 3850N, Hobart Model HS7N or other brands meeting bid specifications</p> <p>Brand Offered: _____</p> <p>Model Offered: _____</p> <p>Warranty Period: _____</p> <p>Delivery (days ARO): _____</p>		

VENDOR NAME: _____
BNG

The School Board of Broward County, Florida
CAFETERIA EQUIPMENT

SECTION 5, BID SUMMARY SHEET (Continued)

		<u>UNIT PRICE</u>	<u>TOTAL COST</u>
ITEM 35: (TO BE AWARDED AS A GROUP)			
A.	2 each	\$ _____	/ea \$ _____
	SAP #6001100 MIXER, 20 QUART 1/2 H.P. minimum motor. Electrical 115/60/1 with three-wire ground cord and a six-foot cord with plug and thermal overload protection. Three positive speed gear driven transmission or variable speed belt drive (low, intermediate and high). Table model to be equipped with a 15 minute (minimum) timed mixing control which automatically shuts off machine in any speed after set time has elapsed. Unit to be standard metallic gray finish, polyurethane enamel or powder coat, corrosion resistant primer. Standard equipment: (1) 20-quart stainless steel bowl, (1) "B" flat beater, (1) "D" wire whip, stainless steel bowl guard or stainless steel screen, cord and plug must be shipped with order. NSF and U.L. Approved/Listed. Warranty: Two year manufacturer's warranty, all parts and labor, must be included in the unit price. Inside delivery and set-up required Approved Brands: Hobart Model HL2000, Varimixer Model W20JNH with optional 15 minute timer and bowl guard, Globe Model SP20 ONLY. Brand Offered: _____ Model Offered: _____ Warranty Period: _____ Delivery (days ARO): _____		
B.	2 each	\$ _____	/ea \$ _____
	SAP #6001101 BOWL, STAINLESS STEEL FOR 20 QUART MIXER Must be compatible and be the same brand as Item 35A. Approved Brands: Hobart, Varimixer, Globe ONLY. Brand Offered: _____ Model Offered: _____ Warranty Period: _____ Delivery (days ARO): _____		
C.	2 each	\$ _____	/ea \$ _____
	SAP #6001102 BEATER, FLAT "B" FOR 20 QUART MIXER Must be compatible and be the same brand as Item 35A. Approved Brands: Hobart, Varimixer, Globe ONLY. Brand Offered: _____ Model Offered: _____ Warranty Period: _____ Delivery (days ARO): _____		

VENDOR NAME: _____
BNG

The School Board of Broward County, Florida
CAFETERIA EQUIPMENT

SECTION 5, BID SUMMARY SHEET (Continued)

		<u>UNIT PRICE</u>	<u>TOTAL COST</u>
<u>ITEM 35: (TO BE AWARDED AS A GROUP)</u>			
D.	2 each	SAP #6001103	\$ _____ /ea \$ _____
		HOOK, DOUGH FOR 20 QUART MIXER	
		Must be compatible and be the same brand as Item 35A.	
		Approved Brands: Hobart, Varimixer, Globe ONLY.	
		Brand Offered: _____	
		Model Offered: _____	
		Warranty Period: _____	
		Delivery (days ARO): _____	
E.	2 each	SAP #6001104	\$ _____ /ea \$ _____
		WHIP, "D" WIRE LOOP FOR 20 QUART MIXER	
		Must be compatible and be the same brand as Item 35A.	
		Approved Brands: Hobart, Varimixer, Globe ONLY.	
		Brand Offered: _____	
		Model Offered: _____	
		Warranty Period: _____	
		Delivery (days ARO): _____	
TOTAL BID ITEM 35 (A – E inclusive)			\$ _____

VENDOR NAME: _____
BNG

The School Board of Broward County, Florida
CAFETERIA EQUIPMENT

SECTION 5, BID SUMMARY SHEET (Continued)

		<u>UNIT PRICE</u>	<u>TOTAL COST</u>
ITEM 36: (TO BE AWARDED AS A GROUP)			
A.	2 each	\$ _____	/ea \$ _____
	<p>SAP #6001082 MIXER, 30 QUART 3/4 H. P. (minimum), electrical 115/60/1 with three wire ground cord and a six foot cord with plug and thermal overload protection. AMP Draw not to exceed 12.0 for 15 AMP Circuit (must not exceed 12 AMPS with cord and NEMA 5-15P). Transmission for unit to be gear driven, constant mesh and internally ventilated or variable speed belt drive. Three fixed speeds; low, intermediate and high. Motor to have permanently lubricated ball bearings and totally enclosed. Bowl-lift to be spring-balanced that locks automatically at top or bottom, adjustable to assure proper clearance between bowl and beater. Unit to be gray powder coat on top of corrosion resistant primer. Floor model, three speed or variable speed, to be equipped with a 15 minute (minimum) timed mixing control which automatically shuts off machine in any speed after set time has elapsed. Stainless steel wire bowl guard. Marked on and off switch. Smooth finish - no hard to clean projections or crevices. Non-Slip rubber or stainless steel feet pads installed to prevent rust. Required Equipment: (1) 30-quart stainless steel bowl, (1) "B" flat beater, (1) "D" wire whip and stainless steel bowl guard or stainless steel screen, cord and plug must be shipped with order and included into the unit price. NSF and U.L. Approved/Listed. Warranty: Two year manufacturer's warranty, all parts and labor, must be included in the unit price. Inside delivery and set-up required Approved Brands: Hobart Model HL300, Globe Model SP30 Varimixer W30A ONLY Brand Offered: _____ Model Offered: _____ Warranty Period: _____ Delivery (days ARO): _____</p>		
B.	2 each	\$ _____	/ea \$ _____
	<p>SAP #6001083 BOWL, STAINLESS STEEL FOR 30 QUART MIXER Must be compatible and be the same brand as Item 36A. Approved Brands: Hobart, Globe Varimixer ONLY Brand Offered: _____ Model Offered: _____ Warranty Period: _____ Delivery (days ARO): _____</p>		

VENDOR NAME: _____
BNG

The School Board of Broward County, Florida
CAFETERIA EQUIPMENT

SECTION 5, BID SUMMARY SHEET – (Continued)

		UNIT PRICE	TOTAL COST
ITEM 36: (TO BE AWARDED AS A GROUP)			
C.	2 each	SAP #6001084 BEATER, FLAT “B” FOR 30 QUART MIXER Must be compatible and be the same brand as Item 36A. Approved Brands: Hobart, Globe, Varimixer ONLY Brand Offered: _____ Model Offered: _____ Warranty Period: _____ Delivery (days ARO): _____	\$ _____ /ea \$ _____
D.	2 each	SAP #6001085 HOOK, DOUGH FOR 30 QUART MIXER Must be compatible and be the same brand as Item 36A. Approved Brands: Hobart, Globe, Varimixer ONLY Brand Offered: _____ Model Offered: _____ Warranty Period: _____ Delivery (days ARO): _____	\$ _____ /ea \$ _____
E.	2 each	SAP #6001086 WHIP, “D” WIRE LOOP FOR 30 QUART MIXER Must be compatible and be the same brand as Item 36A. Approved Brands: Hobart, Globe, Varimixer ONLY Brand Offered: _____ Model Offered: _____ Warranty Period: _____ Delivery (days ARO): _____	\$ _____ /ea \$ _____
F.	2 each	SAP #6001087 DOLLY, BOWL TRUCK FOR 30 QUART MIXER Must be compatible and be the same brand as Item 36A. Assists in moving bowls from mixer stand. <u>Unit price must include demonstration at school and two year warranty on parts and labor from date of installation at school.</u> Approved Brands: Hobart, Globe, Varimixer ONLY Brand Offered: _____ Model Offered: _____ Warranty Period: _____ Delivery (days ARO): _____	\$ _____ /ea \$ _____
TOTAL BID ITEM 36 (A – F inclusive)			\$ _____

VENDOR NAME: _____
BNG

The School Board of Broward County, Florida
CAFETERIA EQUIPMENT

SECTION 5, BID SUMMARY SHEET (Continued)

		<u>UNIT PRICE</u>	<u>TOTAL COST</u>
ITEM 37: (TO BE AWARDED AS A GROUP)			
A.	5 each	\$ _____	/ea \$ _____
	<p>SAP #6001088 MIXER, 40 QUART 1-1/2 H.P. or 2 H.P. (minimum), electrical 208/60/1, single phase or 3-phase floor model, three-speed mixer or variable speed with thermal overload protection. Bowl-lift hand operated, self-locking in up or down position with bowl height sensing. Three positive speeds; low, intermediate and high. Gear driven constant mesh transmission or variable speed belt drive. Motor to have permanently lubricated anti-friction ball bearings. Unit to be gray polyurethane enamel or powder coat on top of corrosion resistant primer. To be equipped with a 15 minute (minimum) timed mixing control which automatically shuts off machine in any speed after set time has elapsed. Stainless steel wire bowl guard. Guard lifts or swings to disengage motor. "Start - Stop" push buttons. Smooth finish, no hard to clean projections or crevices. <u>Stainless steel feet or PVC feet pads installed to prevent rust.</u> Required Equipment: <u>(1) 40-quart stainless steel bowl, (1) "B" flat beater, (1) "D" wire whip, (1) stainless steel dough hook and stainless steel bowl guard or stainless steel screen, cord and plug must be shipped with order and included into the unit price.</u> NSF and U.L. listed. Warranty: Two year manufacturer's warranty, all parts and labor, must be included in the unit price. Inside delivery and set-up required Approved Brands: Hobart Model HL400, Varimixer Model W40A, Globe Model SP40 ONLY.</p> <p>Brand Offered: _____ Model Offered: _____ Warranty Period: _____ Delivery (days ARO): _____</p>		
B.	5 each	\$ _____	/ea \$ _____
	<p>SAP #6001083 BOWL, STAINLESS STEEL FOR 40 QUART MIXER Must be compatible and be the same brand as Item 37A. Approved Brands: Hobart, Varimixer, Globe ONLY. Brand Offered: _____ Model Offered: _____ Warranty Period: _____ Delivery (days ARO): _____</p>		

VENDOR NAME: _____
BNG

The School Board of Broward County, Florida
CAFETERIA EQUIPMENT

SECTION 5, BID SUMMARY SHEET (Continued)

		UNIT PRICE	TOTAL COST
ITEM 37: (TO BE AWARDED AS A GROUP)			
C.	5 each	SAP #6001090 BEATER, FLAT "B" FOR 40 QUART MIXER Must be compatible and be the same brand as Item 37A. Approved Brands: Hobart, Varimixer, Globe ONLY. Brand Offered: _____ Model Offered: _____ Warranty Period: _____ Delivery (days ARO): _____	\$ _____ /ea \$ _____
D.	5 each	SAP #6001092 HOOK, DOUGH FOR 40 QUART MIXER Must be compatible and be the same brand as Item 37A. Approved Brands: Hobart, Varimixer, Globe ONLY. Brand Offered: _____ Model Offered: _____ Warranty Period: _____ Delivery (days ARO): _____	\$ _____ /ea \$ _____
E.	5 each	SAP #6001091 WHIP, "D" WIRE LOOP FOR 40 QUART MIXER Must be compatible and be the same brand as Item 37A. Approved Brands: Hobart, Varimixer, Globe ONLY. Brand Offered: _____ Model Offered: _____ Warranty Period: _____ Delivery (days ARO): _____	\$ _____ /ea \$ _____
F.	5 each	SAP #6004630 DOLLY, BOWL TRUCK FOR 40 QUART MIXER Must be compatible and be the same brand as Item 37A. Assists in moving bowls from mixer stand. <u>Unit price must include demonstration at school and two year warranty on parts and labor from date of installation at school.</u> Approved Brands: Hobart, Varimixer, Globe ONLY. Brand Offered: _____ Model Offered: _____ Warranty Period: _____ Delivery (days ARO): _____	\$ _____ /ea \$ _____
TOTAL BID ITEM 37 (A – F inclusive)			\$ _____

VENDOR NAME: _____
BNG

The School Board of Broward County, Florida
CAFETERIA EQUIPMENT

SECTION 5, BID SUMMARY SHEET (Continued)

		<u>UNIT PRICE</u>	<u>TOTAL COST</u>
ITEM 38: (TO BE AWARDED AS A GROUP)			
A.	2 each	\$ _____	/ea \$ _____
	<p>SAP #6001094 MIXER, 60 QUART 2.7 H.P. (minimum), electrical (208/60/3 or 1) single phase or three phase, floor model, three to four speed mixer, or variable speed mixer with thermal overload protection. Transmission for unit to be gear driven, constant mesh or variable speed belt drive. Motor to have permanently lubricated ball bearings and totally enclosed motor. Stainless steel wire bowl guard. Guard disengages motor to lift or swing open. Unit to be gray polyurethane enamel on top of corrosion resistant primer. To be equipped with a 15 minute (minimum) timed mixing control which automatically shuts off machine in any speed after set time has elapsed. "Start - Stop" push buttons. <u>Stainless steel feet or PVC feet pads installed to prevent rust.</u> Smooth finish, no hard to clean projections or crevices. <u>Standard Accessory Package: (1) 60-quart stainless steel bowl, (1) "B" flat beater, (1) "D" wire whip, (1) stainless steel dough hook and stainless steel bowl guard or stainless steel screen, cord and plug must be shipped with order and be included into the unit price.</u> NSF and U.L. Approved/Listed. Warranty: Two year manufacturer's warranty, all parts and labor, must be included in the unit price. Inside delivery and set-up required Approved Brands: Hobart Model HL-600, Varimixer Model W60A, Globe Model SP60 ONLY.</p> <p>Brand Offered: _____ Model Offered: _____ Warranty Period: _____ Delivery (days ARO): _____</p>		
B.	2 each	\$ _____	/ea \$ _____
	<p>SAP #6001095 BOWL, STAINLESS STEEL FOR 60 QUART MIXER Must be compatible and be the same brand as Item 38A. Approved Brands: Hobart, Varimixer, Globe ONLY. Brand Offered: _____ Model Offered: _____ Warranty Period: _____ Delivery (days ARO): _____</p>		

VENDOR NAME: _____
BNG

The School Board of Broward County, Florida
CAFETERIA EQUIPMENT

SECTION 5, BID SUMMARY SHEET (Continued)

		UNIT PRICE	TOTAL COST
<u>ITEM 38: (TO BE AWARDED AS A GROUP)</u>			
C.	2 each SAP #6001096 BEATER, FLAT "B" FOR 60 QUART MIXER Must be compatible and be the same brand as Item 38A. Approved Brands: Hobart, Varimixer, Globe ONLY. Brand Offered: _____ Model Offered: _____ Warranty Period: _____ Delivery (days ARO): _____	\$ _____	/ea \$ _____
D.	2 each SAP #6001097 HOOK, DOUGH FOR 60 QUART MIXER Must be compatible and be the same brand as Item 38A. Approved Brands: Hobart, Varimixer, Globe ONLY. Brand Offered: _____ Model Offered: _____ Warranty Period: _____ Delivery (days ARO): _____	\$ _____	/ea \$ _____
E.	2 each SAP #6001098 WHIP, "D" WIRE LOOP FOR 60 QUART MIXER Must be compatible and be the same brand as Item 38A. Approved Brands: Hobart, Varimixer, Globe ONLY. Brand Offered: _____ Model Offered: _____ Warranty Period: _____ Delivery (days ARO): _____	\$ _____	/ea \$ _____
F.	2 each SAP #6001099 DOLLY, BOWL TRUCK FOR 60 QUART MIXER Must be compatible and be the same brand as Item 38A. Assists in moving bowls from mixer stand. <u>Unit price must include demonstration at school and two year warranty on parts and labor from date of installation at school.</u> Approved Brands: Hobart, Varimixer, Globe ONLY. Brand Offered: _____ Model Offered: _____ Warranty Period: _____ Delivery (days ARO): _____	\$ _____	/ea \$ _____
TOTAL BID ITEM 38 (A – F inclusive)			\$ _____

VENDOR NAME: _____
BNG

The School Board of Broward County, Florida
CAFETERIA EQUIPMENT

SECTION 5, BID SUMMARY SHEET (Continued)

		<u>UNIT PRICE</u>	<u>TOTAL COST</u>
<u>ITEM 39:</u>	20 each	SAP #6002181 CABINET, NARROW WARMING – DOUBLE COMPARTMENT Heavy-duty construction with 22 gauge stainless steel exterior casing and two (2) 22 gauge stainless steel doors. Each compartment is separately controlled with their own on/off adjustable thermostats, indicator lights and temperature gauges for inside temperature readings. Approx. dimensions 22”w x 32”d x 75”h. <u>Width not to exceed 24”</u> . Include 5” heavy-duty neoprene casters, two swivel, two with brakes. Stainless steel slide racks with capacity for minimum of eight (8) each 18” x 26” sheet pans per cavity. Pan slides to support sheet pan from underside. Maximum amp draw not to exceed 10 amps at 208 Volts, single phase. Total capacity of sixteen (16) 18” x 13” sheet pans per unit (3” spacing). Warranty: Two year manufacturer’s warranty, all parts and labor must be included in the unit price. Price must include inside delivery and complete operational set-up and demonstration. Approved Brand: Alto-Sham Model 1000-UP or other brands meeting bid specifications.	\$ _____ /ea \$ _____

Brand Offered: _____
Model Offered: _____
Warranty Period: _____
Delivery (days ARO): _____

VENDOR NAME: _____
BNG

The School Board of Broward County, Florida
CAFETERIA EQUIPMENT

SECTION 5, BID SUMMARY SHEET (Continued)

		<u>UNIT PRICE</u>	<u>TOTAL COST</u>
<u>ITEM 40:</u>	30 each SAP # _____	\$ _____	/ea \$ _____
<p>HEATED HOLDING & HUMIDIFIED CABINET – DUTCH DOORS</p> <p>Fully insulated and welded base frame construction with two doors. 20 gauge stainless steel polished exterior and 22 gauge interior with easy-to-clean coved corners. Welded tubular base frame shall be 1" square, heavy gauge stainless steel tubing, with 10-gauge stainless steel reinforcing stress plate at corners. Insulation to be UG-26 High gauge density fiberglass throughout or fiberglass insulation of .23 K-factor at 75 degrees Fahrenheit. Flush mounted stainless steel insulated doors. High temperature gasket sealed gasket. Each door shall have two heavy-duty edgemounted die cast hinges. Magnetic door latch and positive closing. High and latch mountings reinforced with stainless steel backing plates. Maintenance free tire casters, two rigid and two swivel with brake. Caster plate secured to a 10 gauge stainless steel reinforcing steel plate via welded in place stainless steel studs. Built in humidified holding system to include two separate long life nickel-chromium alloy heating elements per cavity; separate adjustable controls for each function. One control for the interior air temperature and one to control interior air moisture. 12" x 20" stainless steel reservoir shall be removable for ease of cleaning/sanitation. Hi-temp self-lubricated protected fan-cooled blower motor for moist air distribution. Controls shall be up-front recessed and eye-level. Thermostat from 90 to 190 degrees. Welded stainless steel tray slides fully adjustable and removable designed for bottom tray support. Provide 16 pairs of tray/pan slides on 3" spacing. 120 volts single phase. Nema 5-15P 3 wire grounded 10 foot long power cord and plug, side mounted. Amp draw not to exceed 16.0. Front and recessed control panel with separate set, air moisture, and air temperature controls. Maximum dimensions 29" W x 32" D x 73" H. Include 5" heavy-duty neoprene casters, two swivel, two with brakes. Stainless steel wire universal angle racks to support sheet pans or steam table pans from underside with capacity for minimum of eight (8) each 18" x 26" sheet pans per cavity. Built-in humidity system with removable humidity pan. Total capacity of sixteen (16) 18" x 26" sheet pans per unit (3" spacing). Warranty: Two year manufacturer's warranty, all parts and labor must be included in the unit price. Price must include inside delivery and complete operational set-up and demonstration. Energy Star Approved.</p> <p>Approved Brand: FWE MTU-12 with Dutch doors or other brands meeting bid specifications.</p> <p>Brand Offered: _____</p> <p>Model Offered: _____</p> <p>Warranty Period: _____</p> <p>Delivery (days ARO): _____</p>			

VENDOR NAME: _____
BNG

The School Board of Broward County, Florida
CAFETERIA EQUIPMENT

SECTION 5, BID SUMMARY SHEET (Continued)

	<u>UNIT PRICE</u>	<u>TOTAL COST</u>
<p>ITEM 41: 5 each SAP #6002181 COMBITHERM, CTP7-20E, ELECTRIC Alto-Shaam Combitherm® CT PROformance™ counter-top model CTP7-20E electric Combi-Oven with self-contained boiler, designed with EcoSmart® technology for reduced energy and water consumption. Includes operational modes for steam, convection, a combination of steam and convection heat, and retherm. Oven is to be constructed of 18 gauge stainless steel interior cavity. Oven includes an attached retractable hand shower spray hose with safety shutoff interlock system and a backflow preventer. PROtouch™ control features includes a cool-down function, automatic cleaning function, recipe programming, two power levels, 0- 100% humidity levels, auto-reversing fan with five (5) fan speeds, multi-shelf timers, and sleep mode. Oven includes USB port, HACCP data access, and four (4) adjustable stainless steel legs. Each oven is to accommodate up to seven (7) full-size sheet pans or fourteen (14) full-size hotel pans (GN 1/1), include standard right-hand door hinging, seven (7) non-tilt support rails, and four (4) stainless steel shelves. <u>Interior Dimensions:</u> (HxWxD) 23-1/4" x 24-1/4" x 32-3/4" (590mm x 616mm x 832mm); <u>Exterior Dimensions:</u> (HxWxD) 37-13/16" x 43-3/4" x 46- 3/16" (961mm x 1111mm x 1173mm) <u>Water Requirements:</u> ONE (1) TREATED WATER INLET: 3/4" NPT* ONE (1) UNTREATED WATER INLET: 3/4" NPT* LINE PRESSURE: 30 to 90 psi 2.1 to 6.3 bar <u>Water Drain:</u> 1-1/2" (40mm) CONNECTION WITH A 2" (51mm) MINIMUM AIR GAP INSTALLED AS CLOSE TO THE OVEN AS POSSIBLE. MATERIALS MUST WITHSTAND TEMPERATURES UP TO 200°F (93°C). Can Manifold off of one 3/4" line. <u>Filter:</u> Complete with Everpure Klean Steam II Twin Filter System *Order 2 ea. 4FC5 (EV9693-21) in lieu of 2 ea. 7CB5 (EV9618-16) <u>Electrical Requirements:</u> (NO CORD, NO PLUG, DEDICATED CIRCUIT REQUIRED) DO NOT CONNECT TO A G.F.I. OUTLET: 208-240V/50/60/3-ph, 45.7-52.7 amps, 16.5-21.9kw, 4-3 AWG Warranty: One year manufacturer's warranty, all parts and labor must be included in the unit price. Price must include inside delivery and complete operational set-up and demonstration. Approved Brand: Alto-Sham Model CTP7-20E or other brands meeting bid specifications. Brand Offered: _____ Model Offered: _____ Warranty Period: _____ Delivery (days ARO): _____</p>	<p>\$ _____</p>	<p>/ea \$ _____</p>

VENDOR NAME: _____
BNG

The School Board of Broward County, Florida
CAFETERIA EQUIPMENT

SECTION 5, BID SUMMARY SHEET (Continued)

<u>ITEM 42:</u>	<u>UNIT PRICE</u>	<u>TOTAL COST</u>
15 each SAP #6002181 COMBITHERM, CTP10-20E, ELECTRIC Alto-Shaam Combitherm® CT PROformance™ counter-top model CTP10-20E electric Combi-Oven with self-contained boiler, designed with EcoSmart® technology for reduced energy and water consumption. Includes operational modes for steam, convection, a combination of steam and convection heat, and retherm. Oven is to be constructed of 18 gauge stainless steel interior cavity. Oven includes an attached retractable hand shower spray hose with safety shutoff interlock system and a backflow preventer. PROtouch™ control features includes a cool-down function, automatic cleaning function, recipe programming, two power levels, 0-100% humidity levels, auto-reversing fan with five (5) fan speeds, multi-shelf timers, and sleep mode. Oven includes USB port, HACCP data access, and four (4) adjustable stainless steel legs. Each oven is to accommodate up to ten (10) full-size sheet pans or twenty (20) full-size hotel pans (GN 1/1), include standard right-hand door hinging, ten (10) non-tilt support rails, and five (5) stainless steel shelves. <u>Interior Dimensions:</u> (HxWxD) 31-1/2" x 24-1/4" x 32-3/4" (800mm x 616mm x 832mm); <u>Exterior Dimensions:</u> (HxWxD) 45-11/16" x 43-3/4" x 46-3/16" (1160mm x 1111mm x 1173mm) <u>Water Requirements:</u> ONE (1) TREATED WATER INLET: 3/4" NPT* ONE (1) UNTREATED WATER INLET: 3/4" NPT* LINE PRESSURE: 30 to 90 psi 2.1 to 6.3 bar <u>Water Drain:</u> 1-1/2" (40mm) CONNECTION WITH A 2" (51mm) MINIMUM AIR GAP INSTALLED AS CLOSE TO THE OVEN AS POSSIBLE. MATERIALS MUST WITHSTAND TEMPERATURES UP TO 200°F (93°C). Can Manifold off of one 3/4" line. <u>Filter:</u> Complete with Everpure Klean Steam II Twin Filter System *Order 2 ea. 4FC5 (EV9693-21) in lieu of 2 ea. 7CB5 (EV9618-16) <u>Electrical Requirements:</u> (NO CORD, NO PLUG, DEDICATED CIRCUIT REQUIRED) DO NOT CONNECT TO A G.F.I. OUTLET: 208-240V/50/60/3-ph, 68.8-79.4 amps, 24.8-33kw, 2-1AWG Warranty: One year manufacturer's warranty, all parts and labor must be included in the unit price. Price must include inside delivery and complete operational set-up and demonstration . Approved Brand: Alto-Sham Model CTP10-20E or other brands meeting bid specifications. Brand Offered: _____ Model Offered: _____ Warranty Period: _____ Delivery (days ARO): _____	\$ _____	/ea \$ _____

VENDOR NAME: _____
 BNG

The School Board of Broward County, Florida
CAFETERIA EQUIPMENT

SECTION 5, BID SUMMARY SHEET (Continued)

	<u>UNIT PRICE</u>	<u>TOTAL COST</u>
<p>ITEM 43: 2 each SAP #6002181 COMBITHERM, CTP7-20G, Gas Alto-Shaam Combitherm® CT PROformance™ counter-top model CTP7-20G Gas CombiOven designed with EcoSmart® technology for reduced energy and water consumption. Includes operational modes for steam, convection, a combination of steam and convection heat, and retherm. Oven is to be constructed of 18 gauge stainless steel interior cavity. Oven includes an attached retractable hand shower spray hose with safety shutoff interlock system and a backflow preventer. PROtouch™ control features includes a cool-down function, automatic cleaning function, recipe programming, two power levels, 0-100% humidity levels, auto-reversing fan with five (5) fan speeds, multi-shelf timers, and sleep mode. Oven includes USB port, HACCP data access, and four (4) adjustable stainless steel legs. Each oven is to accommodate up to seven (7) full-size sheet pans or fourteen (14) full-size hotel pans (GN 1/1), include standard right-hand door hinging, seven (7) non-tilt support rails, and four (4) stainless steel shelves. <u>Interior Dimensions:</u> (HxWxD) 23-1/4" x 24-1/4" x 32-3/4" (590mm x 616mm x 832mm); <u>Exterior Dimensions:</u> (HxWxD) 37-13/16" x 43-3/4" x 46-3/16" (961mm x 1111mm x 1173mm) <u>Water Requirements:</u> ONE (1) TREATED WATER INLET: 3/4" NPT* ONE (1) UNTREATED WATER INLET: 3/4" NPT* LINE PRESSURE: 30 to 90 psi 2.1 to 6.3 bar <u>Water Drain:</u> 1-1/2" (40mm) CONNECTION WITH A 2" (51mm) MINIMUM AIR GAP INSTALLED AS CLOSE TO THE OVEN AS POSSIBLE. MATERIALS MUST WITHSTAND TEMPERATURES UP TO 200°F (93°C). Can Manifold off of one 3/4" line. <u>Filter:</u> Complete with Everpure DI-Filter System 1ea. Claris EV4339-14 <u>Electrical Requirements:</u> Dedicated circuit required DO NOT CONNECT TO A G.F.I. OUTLET: 120/60/1 6.8 amps, .84kw, 14AWG Nema 5-20p Cord and plug provided Warranty: One year manufacturer's warranty, all parts and labor must be included in the unit price. Price must include inside delivery and complete operational set-up and demonstration. Approved Brand: Alto-Sham Model CTP7-20G or other brands meeting bid specifications. Brand Offered: _____ Model Offered: _____ Warranty Period: _____ Delivery (days ARO): _____</p>	<p>\$ _____</p>	<p>/ea \$ _____</p>

VENDOR NAME: _____
BNG

The School Board of Broward County, Florida
CAFETERIA EQUIPMENT

SECTION 5, BID SUMMARY SHEET (Continued)

		<u>UNIT PRICE</u>	<u>TOTAL COST</u>	
<u>ITEM 44:</u>	10 each	SAP #6002181 COMBITHERM, CTP10-20G, Gas Alto-Shaam Combitherm® CT PROformance™ counter-top model CTP10-20G Gas CombiOven designed with EcoSmart® technology for reduced energy and water consumption. Includes operational modes for steam, convection, a combination of steam and convection heat, and retherm. Oven is to be constructed of 18 gauge stainless steel interior cavity. Oven includes an attached retractable hand shower spray hose with safety shutoff interlock system and a backflow preventer. PROtouch™ control features includes a cool-down function, automatic cleaning function, recipe programming, two power levels, 0-100% humidity levels, auto-reversing fan with five (5) fan speeds, multi-shelf timers, and sleep mode. Oven includes USB port, HACCP data access, and four (4) adjustable stainless steel legs. Each oven is to accommodate up to ten (10) full-size sheet pans or twenty (20) full-size hotel pans (GN 1/1), include standard right-hand door hinging, ten (10) non-tilt support rails, and five (5) stainless steel shelves. <u>Interior Dimensions:</u> (HxWxD) 31-1/2" x 24-1/4" x 32-3/4" (800mm x 616mm x 832mm); <u>Exterior Dimensions:</u> (HxWxD) 45-11/16" x 43-3/4" x 46-3/16" (1160mm x 1111mm x 1173mm) <u>Water Requirements:</u> ONE (1) TREATED WATER INLET: 3/4" NPT* ONE (1) UNTREATED WATER INLET: 3/4" NPT* LINE PRESSURE: 30 to 90 psi 2.1 to 6.3 bar <u>Water Drain:</u> 1-1/2" (40mm) CONNECTION WITH A 2" (51mm) MINIMUM AIR GAP INSTALLED AS CLOSE TO THE OVEN AS POSSIBLE. MATERIALS MUST WITHSTAND TEMPERATURES UP TO 200°F (93°C). Can Manifold off of one 3/4" line. <u>Filter:</u> Complete with Everpure DI-Filter System 1ea. Claris EV4339-14 <u>Electrical Requirements:</u> Dedicated circuit required DO NOT CONNECT TO A G.F.I. OUTLET: 120/60/1 6.8 amps, .84kw, 14AWG Nema 5-20p Cord and plug provided Warranty: One year manufacturer's warranty, all parts and labor must be included in the unit price. Price must include inside delivery and complete operational set-up and demonstration. Approved Brand: Alto-Sham Model CTP10-20G or other brands meeting bid specifications. Brand Offered: _____ Model Offered: _____ Warranty Period: _____ Delivery (days ARO): _____	\$ _____	/ea \$ _____

VENDOR NAME: _____
BNG

The School Board of Broward County, Florida
CAFETERIA EQUIPMENT

SECTION 5, BID SUMMARY SHEET (Continued)

		<u>UNIT PRICE</u>	<u>TOTAL COST</u>
ITEM 45: (TO BE AWARDED AS A GROUP)			
A.	15 each		
	SAP # _____		
	BOILERLESS COMBI OVER STEAMER - ELECTRIC	\$ _____	/ea \$ _____
	<p>All stainless steel exterior & interior, also top and sides. Unit fully insulated. Precision Humidity Control automatically adjusts after setting temperature. One control knob to control temperature and humidity. Multiple cooking capabilities including baking, steaming, rethermalization, and defrost. Visual recall display of actual temperature and humidity. No pre-programming required. Flashing door lights and audible alarm system to alert user when cooking cycle is finished. Auto-reversing fan with electrical braking system on fan motor. Halogen lighting built into the door. Cool to touch and energy efficient heat reflective tempered glass door. Large LED displays for temperature, time and humidity controls. Standard rack guides with five (5) stainless steel wire racks. Capacity for (7) racks for a total of (7) 18" x 26" pans if needed. Unit to be securely bolted to stainless steel stand w/stainless steel legs.</p> <p>Unit to include Hallow Carbon Filter system CB30K-System Electric requirements: Total amp draw not to exceed 55 at 208 v., 3 phase. UL Listed. Minimum two (2) year parts and labor warranty. Price to include freight, inside delivery, set in place, Level, remove packing materials, parts manual, factory start-up, factory demonstration.</p> <p>Approved Brands: Vulcan ABC7E-208 or other brands meeting bid specifications</p> Brand Offered: _____ Model Offered: _____ Warranty Period: _____ Delivery (days ARO): _____		
B.	15 each		
	SAP # _____		
	BOILERLESS COMBI OVEN STEAMER – ELECTRIC	\$ _____	/ea \$ _____
	<p>Same as above except 480 v., 3 phase.</p> Brand Offered: _____ Model Offered: _____ Warranty Period: _____ Delivery (days ARO): _____		

TOTAL BID ITEM 45 (A – B inclusive).....\$ _____

VENDOR NAME: _____
BNG

The School Board of Broward County, Florida
CAFETERIA EQUIPMENT

SECTION 5, BID SUMMARY SHEET (Continued)

ITEM 46:

(TO BE AWARDED AS A GROUP)

A. 30 each SAP #6000808
AUTOMATIC ICE MAKING MACHINE \$ _____ /ea \$ _____
 Modular air cooled ice maker, ARI standard minimum of 249 lbs. at 90 degrees air and 70 degrees water. Medium ice cube size – 7/8" x 7/8" x 7/8". Corrosion-resistant stainless steel exterior. No air filter or front located air filter. 115/60/1 electric requirements only. Max. fuse size 15 amps. Unit to be 22" wide. Air cooled. Complete with factory approved water filter.
WARRANTY: 3 year parts and labor on all components; 5-7 year parts & labor on evaporator; 5 year parts on compressor, condenser.
Note: Unit price shall include installation, set up, placement, shipping, free warranty service calls while machine under warranty, start-up, parts manual. SBBC shall supply existing water line, electric outlets, and drainage.
Approved Brands: Scotsman C0332SA-1A, Manitowac ID-0322A, Ice-O-Matic ICE0320A, Hoshisaki KM-320MAH ONLY.
 Brand Offered: _____
 Model Offered: _____
 Warranty Period: _____
 Delivery (days ARO): _____

B. 30 each SAP #6000805
BIN \$ _____ /ea \$ _____
 Holds minimum 360 lbs. To be compatible with Item A. To have minimum storage capacity of 360 lbs. Front door and sides of bin to be stainless steel or polyethylene exterior. 6" adjustable legs. Foamed-in-place polyurethane insulation. Non-corosive polyliner. **NSF and UL listed.**
WARRANTY: 3 year parts and labor.
Approved Brands, Scotsman B322S, Ice-O-Matic B42, Hoshisaki B-300SF, Manitowac B-320 ONLY
 Brand Offered: _____
 Model Offered: _____
 Warranty Period: _____
 Delivery (days ARO): _____

TOTAL BID ITEM 46 (A – B inclusive).....\$_____

VENDOR NAME: _____
BNG

The School Board of Broward County, Florida
CAFETERIA EQUIPMENT

SECTION 5, BID SUMMARY SHEET (Continued)

ITEM 47:

(TO BE AWARDED AS A GROUP)

- A. 30 each SAP #6000803
AUTOMATIC ICE MAKING MACHINE \$ _____ /ea \$ _____
 (330 lbs.) Modular air cooled ice maker, ARI standard minimum of 368 lbs. at 90 degrees air and 70 degrees water. Medium ice cube size – 7/8" x 7/8" x 7/8". Corrosion-resistant stainless steel exterior. No air filter or front located air filter. 115/60/1 electric requirements only. 30" wide. Air cooled. Complete with factory approved water filter.
WARRANTY: 3 year parts and labor on all components; 5-7 year parts & labor on evaporator; 5 year parts on compressor, condenser.
Note: Unit price shall include installation, set up, placement, shipping, free warranty service calls while machine under warranty, start-up, parts manual. SBBC shall supply existing water line, electric outlets, and drainage.
Approved Brands: Scotsman C0530SA-1A, Manitowac ID052 02-A, Ice-O-Matic ICE0400A ONLY.
 Brand Offered: _____
 Model Offered: _____
 Warranty Period: _____
 Delivery (days ARO): _____
- B. 30 each SAP #6000804
BIN \$ _____ /ea \$ _____
 To be compatible with Item A. Holds minimum 500 lbs. Front door and sides of bin to be stainless steel or polyethylene exterior. 6" adjustable legs. Foamed-in-place polyurethane insulation. Non-corrosive polyliner. NSF and UL listed.
WARRANTY: 3 year parts and labor.
Approved Brands: Scotsman B530P, Ice-O-Matic B42, Hoshisaki B-300SF, Manitowac B-570 ONLY
 Brand Offered: _____
 Model Offered: _____
 Warranty Period: _____
 Delivery (days ARO): _____

TOTAL BID ITEM 46 (A – B inclusive).....\$ _____

VENDOR NAME: _____
BNG

The School Board of Broward County, Florida
CAFETERIA EQUIPMENT

SECTION 5, BID SUMMARY SHEET (Continued)

		<u>UNIT PRICE</u>	<u>TOTAL COST</u>
<u>ITEM 48:</u>	<u>(TO BE AWARDED AS A GROUP)</u>		
A.	20 each	\$ _____	/ea \$ _____
	SAP #6 _____ HOT WELL 60" x 34" x 35" unit. To include; four (4) individually controlled wells, counter protector with stainless steel top, 14 gauge stainless steel server work board, flat tray slide, modified counter and tray slide height per plan. Construction to be one piece of die-formed 14 gauge stainless steel with 1 1/2", 900 nosing on all sides. 12" x 20" top openings with raised die-stamped perimeters. Body frame to be all welded construction of steel with exposed corners to be 1 1/4" stainless steel. All corners welded and polished. Body ends and panels to be plastic laminate with galvanized steel backing (specify laminate color). Body ends and panels to be removable to allow the changing of colors. Unit to be equipped with 4 adjustable legs that are recessed inside of toe area. Unit shipped with 8'- cord & plug installed. Unit comes standard with thermostatic controls. Each controls has a lighted on/off switch that allows turning off of each well. Controls and elements mounted behind removable front panel for easy access to changing elements, element boxes or controls through easy to remove access panel. Individual food wells wired to common junction box(es). Each unit supplied with UL listed power cord. Concealed locking mechanism with easy to use spring-activated catch. 208/240/60/1 22amps. Approved Brands: Randell Model # RAN HTD-4S ONLY Brand Offered: _____ Model Offered: _____ Warranty Period: _____ Delivery (days ARO): _____		

VENDOR NAME: _____
 BNG

The School Board of Broward County, Florida
CAFETERIA EQUIPMENT

SECTION 5, BID SUMMARY SHEET (Continued)

		<u>UNIT PRICE</u>	<u>TOTAL COST</u>
<u>ITEM 48:</u>	<u>(TO BE AWARDED AS A GROUP)</u>		
B.	20 each	\$ _____	/ea \$ _____
	SAP #6 _____ UTILITY COUNTER 72" x 34" x 31" unit. To include; 1ea. single tier deck mounted overshelf 18"deep with 36" heat lamp mounted as shown on plan, adjustable food guard, flat tray slide, modified counter and tray slide height per plan. Construction; top to be one piece of die-formed 14 gauge stainless steel with 1 1/2", 900 nosing on all sides. Body frame to be all welded construction of steel with exposed corners to be 1 1/2" stainless steel. All corners welded and polished. Body ends and panels to be plastic laminated with galvanized steel backing (specify laminate color). Body ends and panels to be removable to allow the changing of colors. Unit provided with a stainless steel work surface. Unit to be equipped with 4 adjustable legs that are recessed inside of toe area. Concealed locking mechanism with easy to use spring-activated catch. Approved Brands: Randell Model # RAN ST-6S ONLY Brand Offered: _____ Model Offered: _____ Warranty Period: _____ Delivery (days ARO): _____		

VENDOR NAME: _____
BNG

The School Board of Broward County, Florida
CAFETERIA EQUIPMENT

SECTION 5, BID SUMMARY SHEET (Continued)

<u>ITEM 48:</u>	<u>(TO BE AWARDED AS A GROUP)</u>	<u>UNIT PRICE</u>	<u>TOTAL COST</u>
C.	20 each		
	SAP #6	\$ _____	/ea \$ _____
	ICE COLD PAN		
	<p>60" x 34" x 31" unit. To include; 1ea. double tier deck mounted overshelf 18" deep with adjustable food guards, flat tray slide, perforated pan insert, modified cold pan depth per plan, modified counter and tray slide height per plan. Construction; top to be one piece of die-formed 14 gauge stainless steel with 1 1/2", 900 nosing on all sides. Unit fitted with 6" deep, ice cooled display cold pan. Interior of pan to be one piece, continuously welded construction of 18 gauge stainless steel. Interior fitted with 1" drain at one end. Drain nipple supplied with ball valve and lever extension to cabinet exterior on enclosed base units- drain lines run to accessible area. 1" high perforated, stainless steel bottom strainer plates provided. Body frame to be all welded construction of steel with exposed corners to be 1 1/2" stainless steel. All corners welded and polished. Body ends and panels to be plastic laminate with galvanized steel backing (specify laminate color). Body ends and panels to be removable to allow the changing of colors. Cold pan insulated with high density (CFC free) polyurethane, foamed in place. Unit to be equipped with 4 adjustable legs that are recessed inside of toe area. Concealed locking mechanism with easy to use spring-activated catch.</p> <p>Approved Brands: Randell Model # RAN IC-4S ONLY</p> <p>Brand Offered: _____</p> <p>Model Offered: _____</p> <p>Warranty Period: _____</p> <p>Delivery (days ARO): _____</p>		

VENDOR NAME: _____
BNG

The School Board of Broward County, Florida
CAFETERIA EQUIPMENT

SECTION 5, BID SUMMARY SHEET (Continued)

		<u>UNIT PRICE</u>	<u>TOTAL COST</u>
ITEM 48:	<u>(TO BE AWARDED AS A GROUP)</u>		
D.	5 each	\$ _____	/ea \$ _____
	SAP #6 _____ CASHIER STAND 48" x 34" x 35" unit. To include; flat tray slide, ferruled utility drop dimension per plan, modified counter and tray slide height per plan. Construction; top to be one piece of die-formed 14 gauge stainless steel with 1 1/2", 900 nosing on all sides. Body frame to be all welded construction of steel with exposed corners to be 1 1/2" stainless steel. All corners welded and polished. Body ends and panels to be plastic laminate with galvanized steel backing (specify laminate color). Body ends and panels to be removable to allow the changing of colors. Unit provided with a stainless steel work surface. Unit to be equipped with 4 adjustable legs that are recessed inside of toe area. Concealed locking mechanism with easy to use spring-activated catch Approved Brands: Randell Model # RAN CA ONLY Brand Offered: _____ Model Offered: _____ Warranty Period: _____ Delivery (days ARO): _____		
E.	15 each	\$ _____	/ea \$ _____
	SAP #6 _____ CASHIER STAND 40" x 34" x 35" unit. To include; flat tray slide, ferruled utility drop dimension per plan, modified counter and tray slide height per plan. Construction; top to be one piece of die-formed 14 gauge stainless steel with 1 1/2", 900 nosing on all sides. Body frame to be all welded construction of steel with exposed corners to be 1 1/2" stainless steel. All corners welded and polished. Body ends and panels to be plastic laminate with galvanized steel backing (specify laminate color). Body ends and panels to be removable to allow the changing of colors. Unit provided with a stainless steel work surface. Unit to be equipped with 4 adjustable legs that are recessed inside of toe area. Concealed locking mechanism with easy to use spring-activated catch. Approved Brands: Randell Model # RAN CA ONLY Brand Offered: _____ Model Offered: _____ Warranty Period: _____ Delivery (days ARO): _____		
TOTAL BID ITEM 48 (A – E inclusive).....		\$ _____	

VENDOR NAME: _____
BNG

The School Board of Broward County, Florida
CAFETERIA EQUIPMENT

SECTION 5, BID SUMMARY SHEET (Continued)

		<u>UNIT PRICE</u>	<u>TOTAL COST</u>
ITEM 49:	<u>(TO BE AWARDED AS A GROUP)</u>		
A.	20 each		
	SAP #6		
	5' COOK'S TABLE w/POT RACK	\$ _____	/ea \$ _____
	<p><u>Note: For all custom made cook's tables, a complete drawing, illustrating the following information, but not limited to dimensions, sizes, types of materials, and accessories, must be furnished for evaluation purposes. Failure to furnish complete drawing will result in disqualification of bid item. To be 60" long x 30" wide x 36" high. To be constructed of 14 gauge series 300 stainless steel, under shelf to be 10" off floor and constructed of 16 gauge series 300 stainless steel. Top and undershelf to have rounded corners; no backsplash. Stainless steel tubular legs with adjustable flanges bullet feet. Complete with stainless steel drawer and stainless steel pan rack. Drawer 20"-22" x 20" x 5", removable, set into stainless steel frame with roller ball bearing slides. Pot rack circular design approx.. 66" long, furnished with 1-5/8" diameter 12 gauge tubular stainless steel supports extending through overshelf and tabletop and fastened securely to undershelf. Top of ran rack to be four (4) feet above table. Pan rack must include a minimum of eighteen pothooks and an overshelf constructed of 15- gauge stainless steel approximately 18" above tabletop and 24" below top of pan rack. Overshelf to be 60" long x 12" wide with stainless steel support extending through it. Also furnish pan rack with stainless steel crossbar approximately 10" below the top with a minimum of twelve pot hooks. Unit price to include freight, inside delivery, complete assembly & set in place at school.</u></p> <p>Approved Brands: Duke, Universal Stainless, Gamanza, SPG International, or other brands meeting bid specifications</p> <p>Brand Offered: _____</p> <p>Model Offered: _____</p> <p>Warranty Period: _____</p> <p>Delivery (days ARO): _____</p>		

VENDOR NAME: _____
BNG

The School Board of Broward County, Florida
CAFETERIA EQUIPMENT

SECTION 5, BID SUMMARY SHEET (Continued)

<u>ITEM 49:</u>	<u>(TO BE AWARDED AS A GROUP)</u>	<u>UNIT PRICE</u>	<u>TOTAL COST</u>
B.	25 each		
	SAP #6		
	6' COOK'S TABLE w/POT RACK	\$ _____	/ea \$ _____
	<p><u>Note: For all custom made cook's tables, a complete drawing, illustrating the following information, but not limited to dimensions, sizes, types of materials, and accessories, must be furnished for evaluation purposes. Failure to furnish complete drawing will result in disqualification of bid item. To be 72" long x 30" wide x 36" high. To be constructed of 14 gauge series 300 stainless steel, undershelf to be 10" off floor and constructed of 16 gauge series 300 stainless steel. Top and undershelf to have rounded corners; no backsplash. Stainless steel tubular with adjustable flanges bullet feet. Complete with stainless steel drawer and stainless steel pan rack. Drawer 20"-22" x 20" x 5", removable, set into stainless steel frame with roller ball bearing slides. Pot rack circular design approx.. 66" long, furnished with 1-5/8" diameter 12 gauge tubular stainless steel supports extending through overshelf and tabletop and fastened securely to undershelf. Top of ran rack to be four (4) feet above table. Pan rack must include a minimum of eighteen pothooks and an overshelf constructed of 15- gauge stainless steel approximately 18" above tabletop and 24" below top of pan rack. Overshelf to be 72" long x 12" wide with stainless steel support extending through it. Also furnish pan rack with stainless steel crossbar approximately 10" below the top with a minimum of twelve pot hooks. Unit price to include freight, inside delivery, complete assembly & set in place at school.</u></p> <p>Approved Brands: Duke, Universal Stainless, SPG International, or other brands meeting bid specifications</p> <p>Brand Offered: _____</p> <p>Model Offered: _____</p> <p>Warranty Period: _____</p> <p>Delivery (days ARO): _____</p>		

TOTAL BID ITEM 49 (A – B inclusive).....\$ _____

VENDOR NAME: _____
BNG

The School Board of Broward County, Florida
CAFETERIA EQUIPMENT

SECTION 5, BID SUMMARY SHEET (Continued)

REQUIRED ADDITIONAL INFORMATION

COMPANY REPRESENTATIVE: (See Special Condition 10)

Company Name

Company Representative

Street Address

City, State and Zip

Phone Number

Fax Number

Local/Toll-Free Phone Number

E-Mail Address

LOCAL SERVICE CENTER: (See Special Condition 10)

Service Center Name

Street Address

City, State and Zip

NOTE TO BIDDER: Review General Condition 49 prior to completing and mailing this bid.

Bidder's M/WBE Certification Number: _____

Agency Issuing This Number: _____

VENDOR NAME: _____

BNG

The School Board of Broward County, Florida
CAFETERIA EQUIPMENT

SECTION 6, ILLUSTRATIONS

BID ITEM 6A/6B

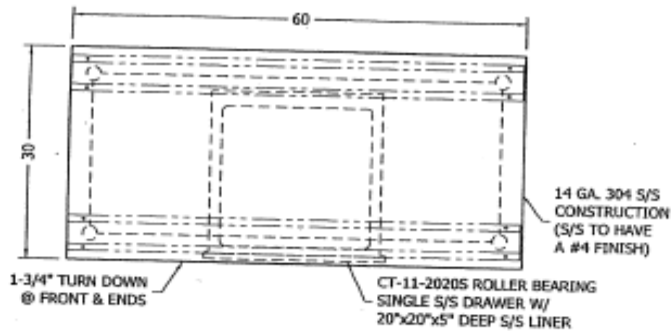

- NOTE:
 1. ALL VISIBLE WELDS TO BE GROUND SMOOTH & POLISHED TO A MATCHING FINISH.
 2. ALL NON-VISIBLE WELDS TO BE GROUND SMOOTH & PAINTED
 3. ALL EDGES TO BE SMOOTH & FREE FROM BURRS

Item A

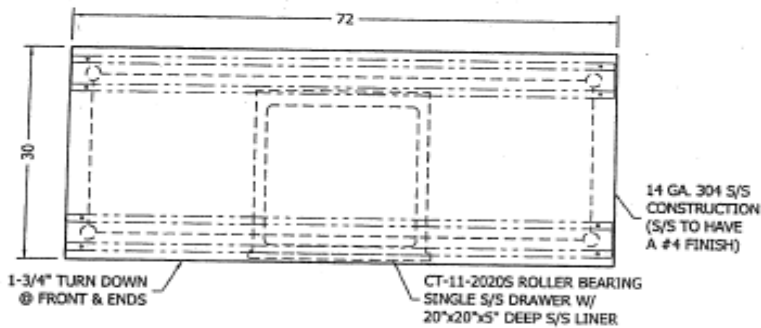
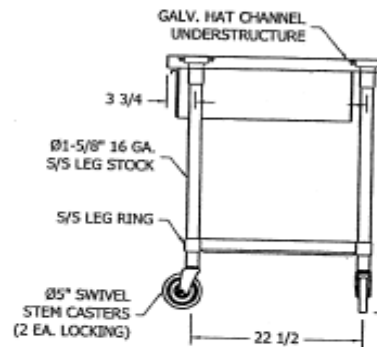
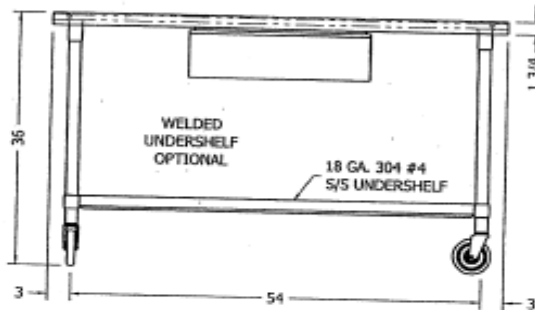

- NOTE:
 1. ALL VISIBLE WELDS TO BE GROUND SMOOTH & POLISHED TO A MATCHING FINISH.
 2. ALL NON-VISIBLE WELDS TO BE GROUND SMOOTH & PAINTED
 3. ALL EDGES TO BE SMOOTH & FREE FROM BURRS

Item B

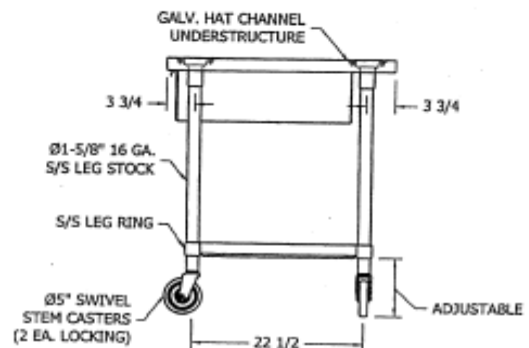
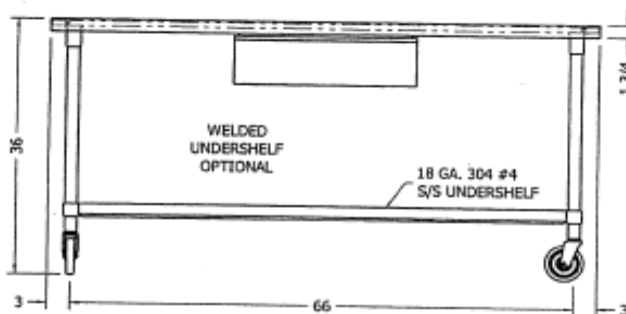

VENDOR NAME: _____
 BNG

The School Board of Broward County, Florida
CAFETERIA EQUIPMENT

SECTION 6, ILLUSTRATIONS

BID ITEM 7A

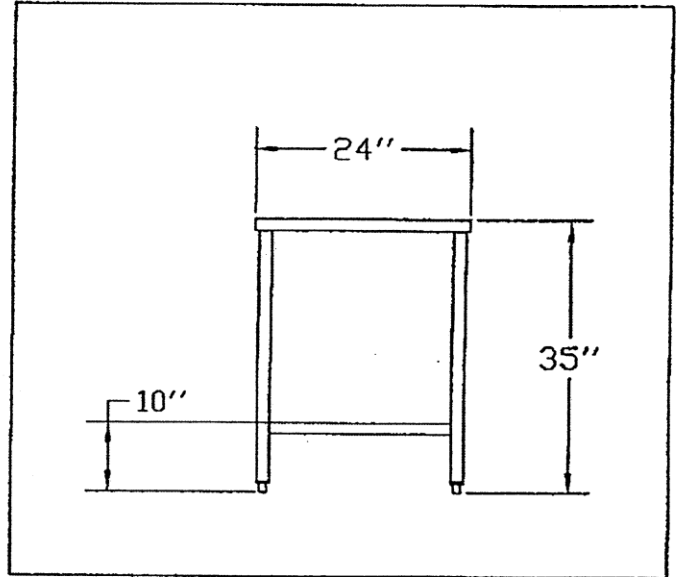
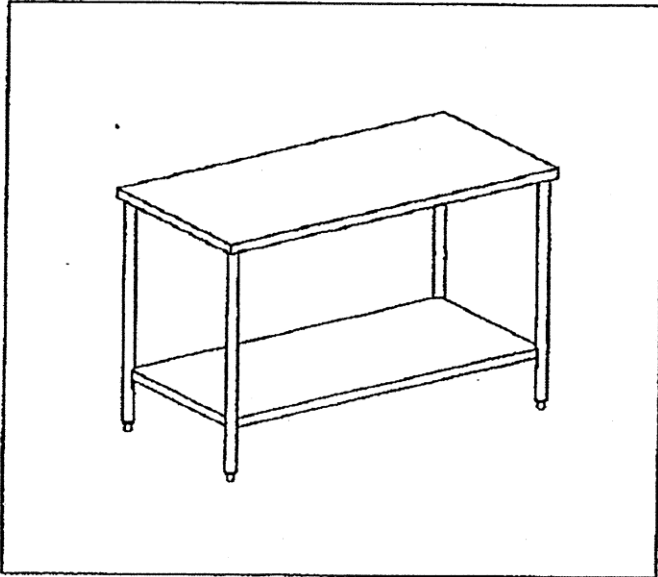

*All stainless steel construction 304 Top 14 ga undershelf 18 ga
no casters no Drawers.*

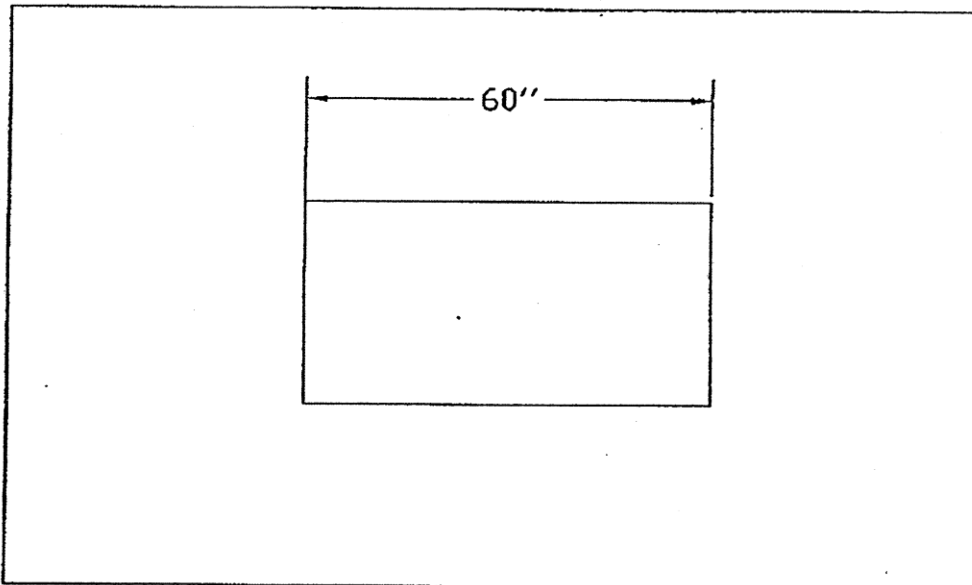

VENDOR NAME: _____

BNG

The School Board of Broward County, Florida
CAFETERIA EQUIPMENT

SECTION 6, ILLUSTRATIONS – (Continued)

BID ITEM 7B

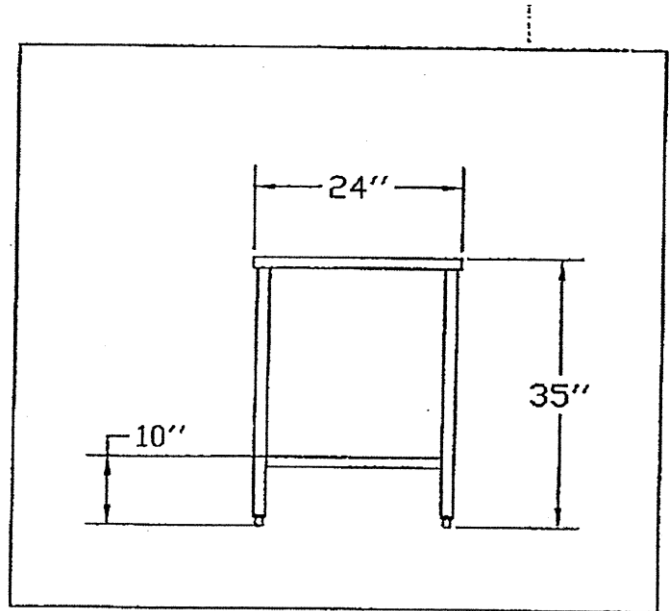
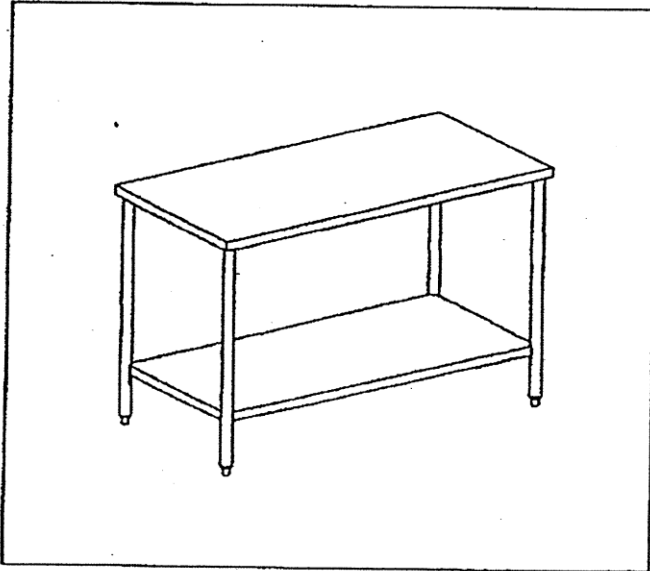

*All stainless steel construction 304 Top 14 ga undershelf 18 ga
no casters no Drawers.*

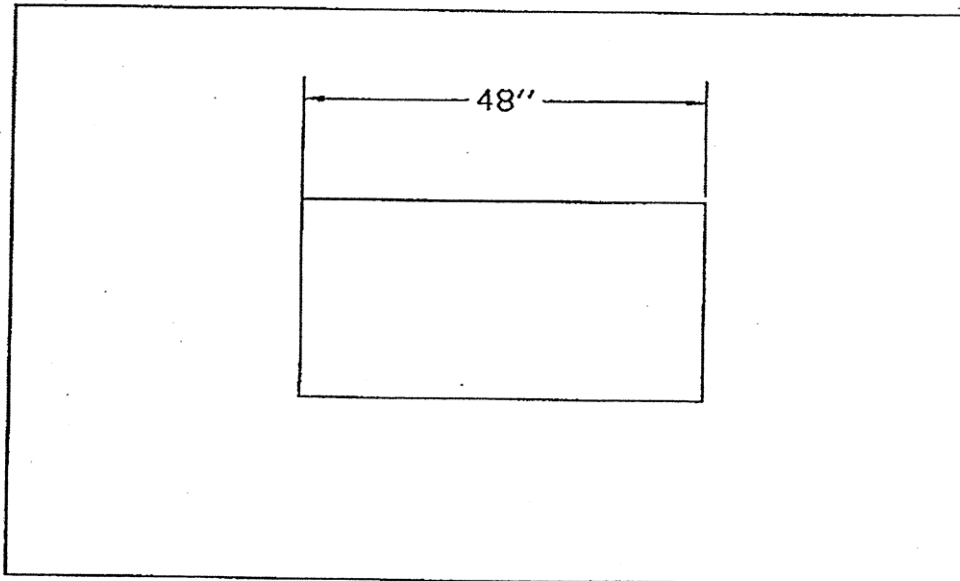

VENDOR NAME: _____
BNG

The School Board of Broward County, Florida
CAFETERIA EQUIPMENT

SECTION 6, ILLUSTRATIONS – (Continued)

BID ITEM 7C

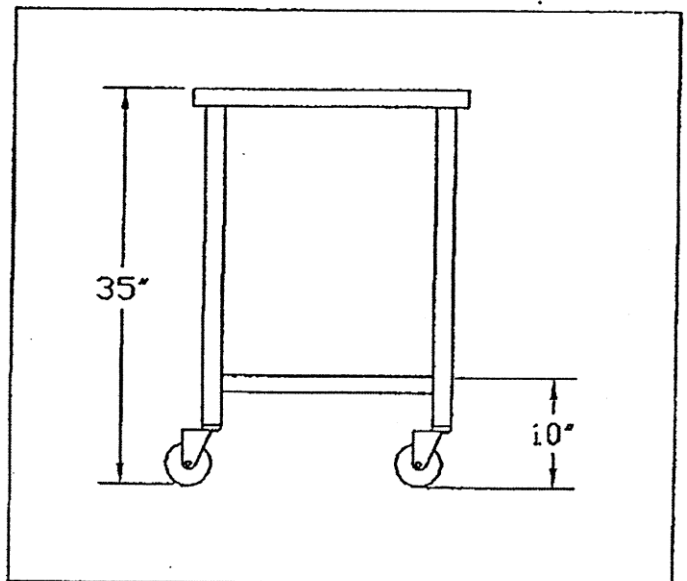
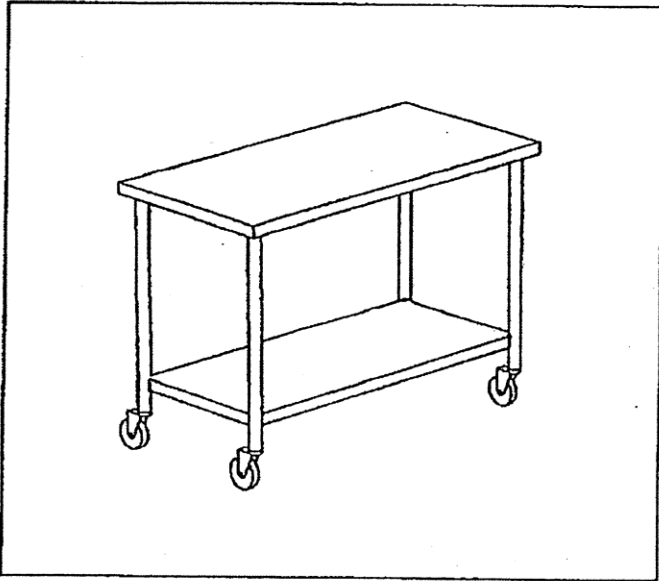

*All stainless steel construction 304 14 Ga top 18 Ga shelf
With casters*

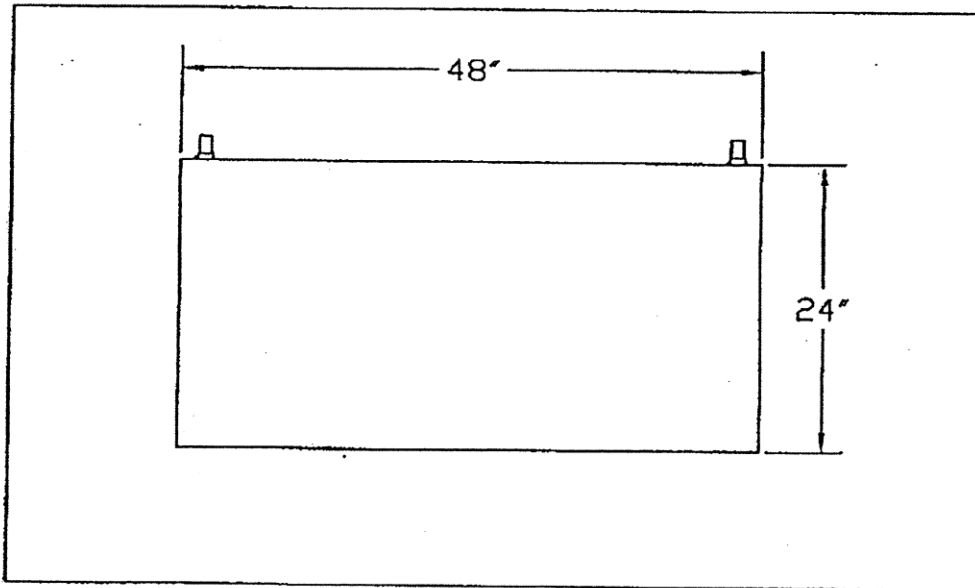

VENDOR NAME: _____
BNG

The School Board of Broward County, Florida
CAFETERIA EQUIPMENT

SECTION 6, ILLUSTRATIONS – (Continued)

BID ITEM 7D

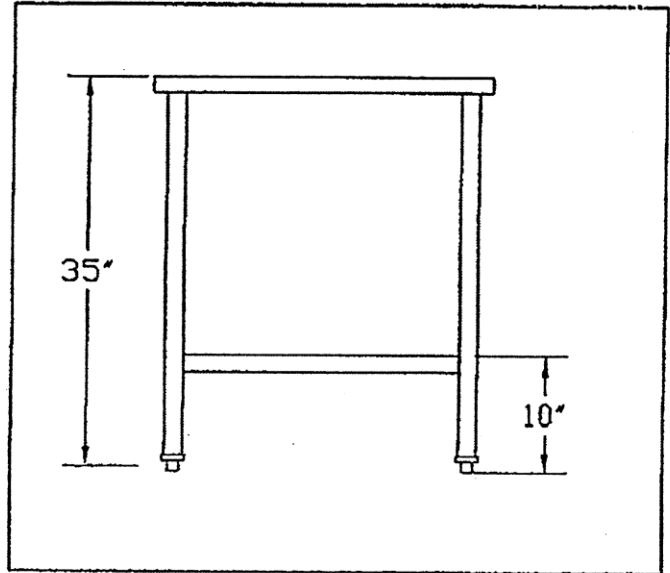
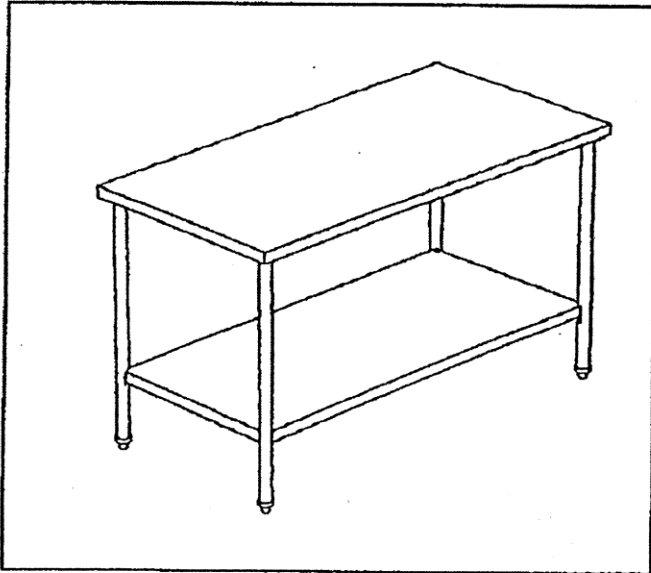

*All stainless steel construction 304 14 Ga top 18 Ga shelf
With casters*

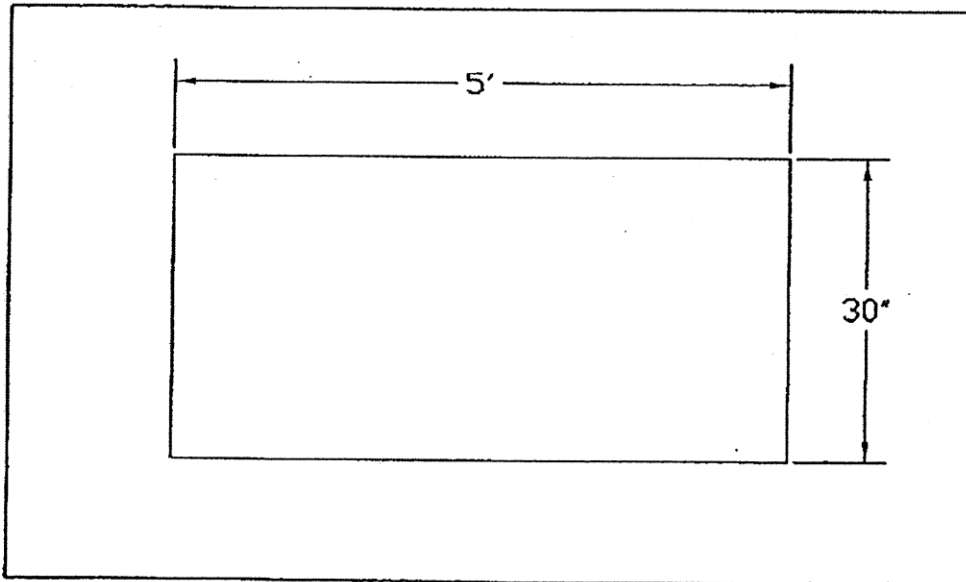

VENDOR NAME: _____
BNG

The School Board of Broward County, Florida
CAFETERIA EQUIPMENT

SECTION 6, ILLUSTRATIONS – (Continued)

BID ITEM 7E

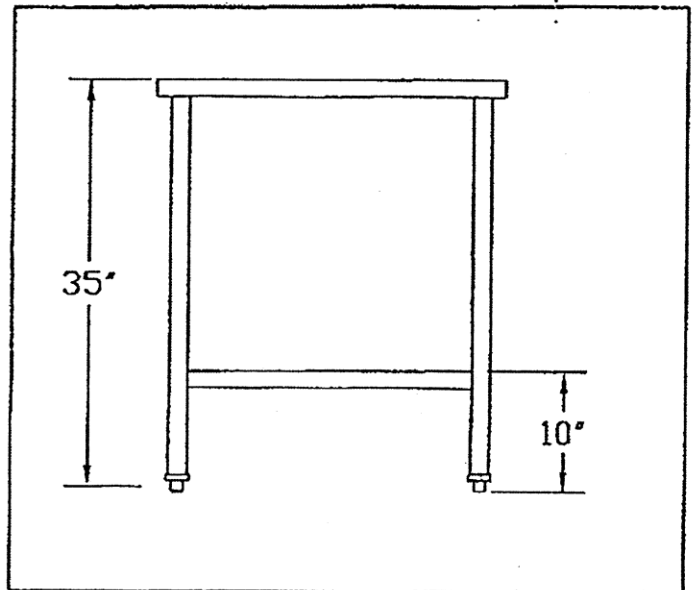
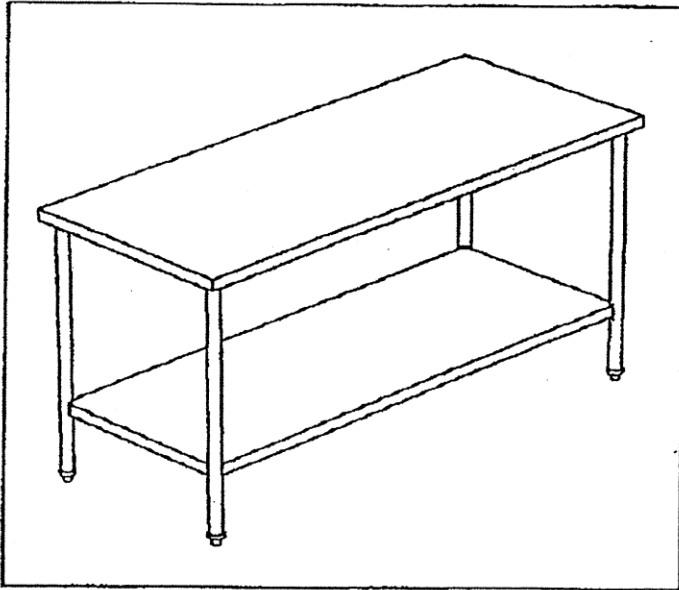

*All stainless steel construction 304 14 Ga top 18 Ga shelf
With casters*

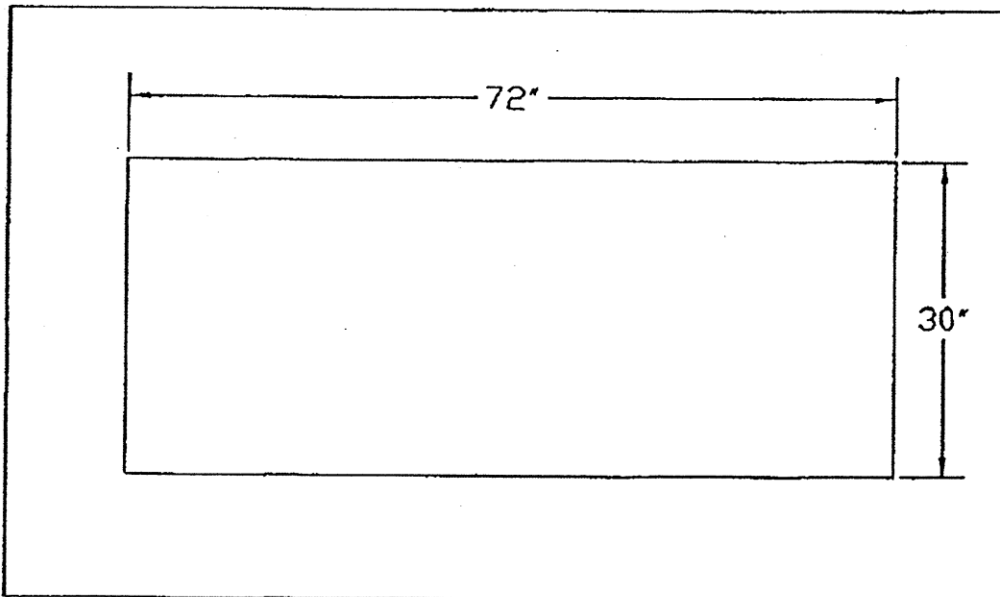

VENDOR NAME: _____
BNG

The School Board of Broward County, Florida
CAFETERIA EQUIPMENT

SECTION 6, ILLUSTRATIONS (Continued)

BID ITEM 7F

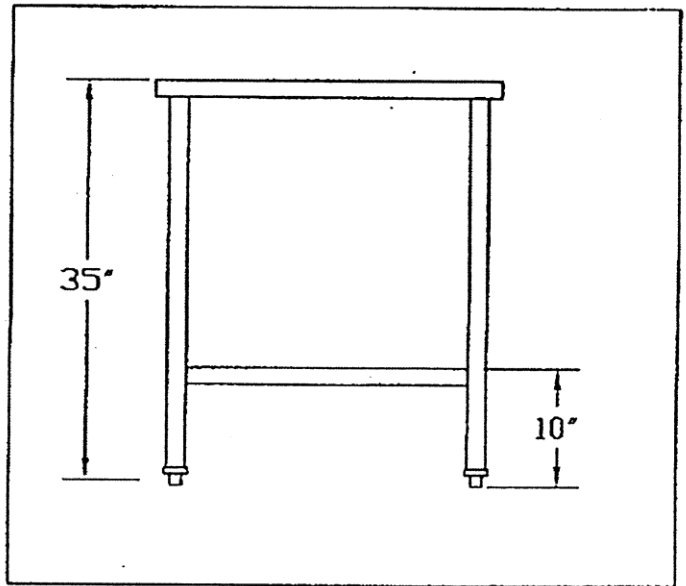
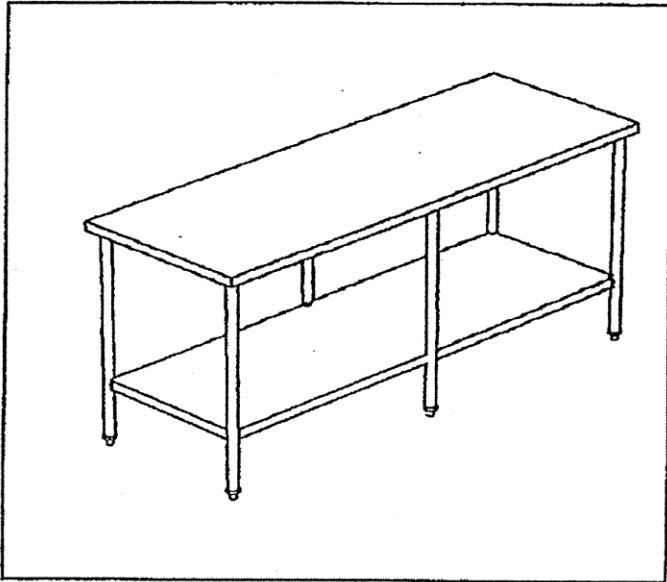

*All stainless steel construction 304 14 Ga top 18 Ga shelf
With casters*

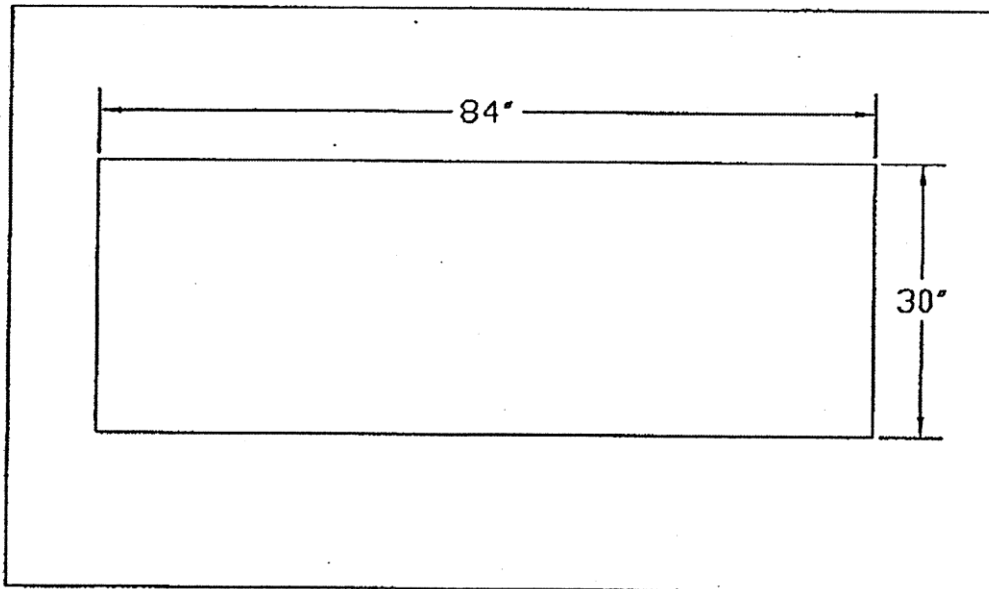

VENDOR NAME: _____
BNG

The School Board of Broward County, Florida
CAFETERIA EQUIPMENT

SECTION 6, ILLUSTRATIONS – (Continued)

BID ITEM 8

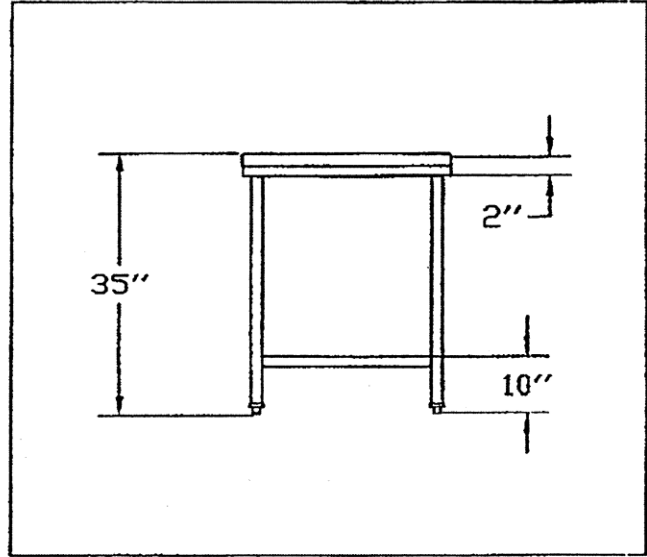
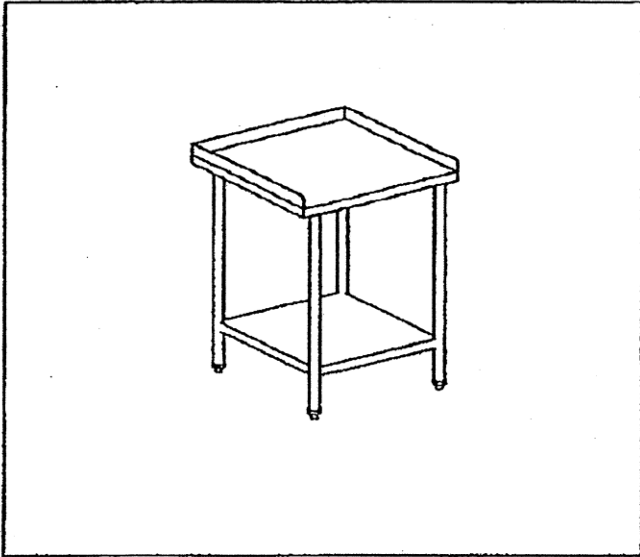

*All stainless steel construction 304 Top 14 ga undershelf 18 ga
no casters no Drawers.*

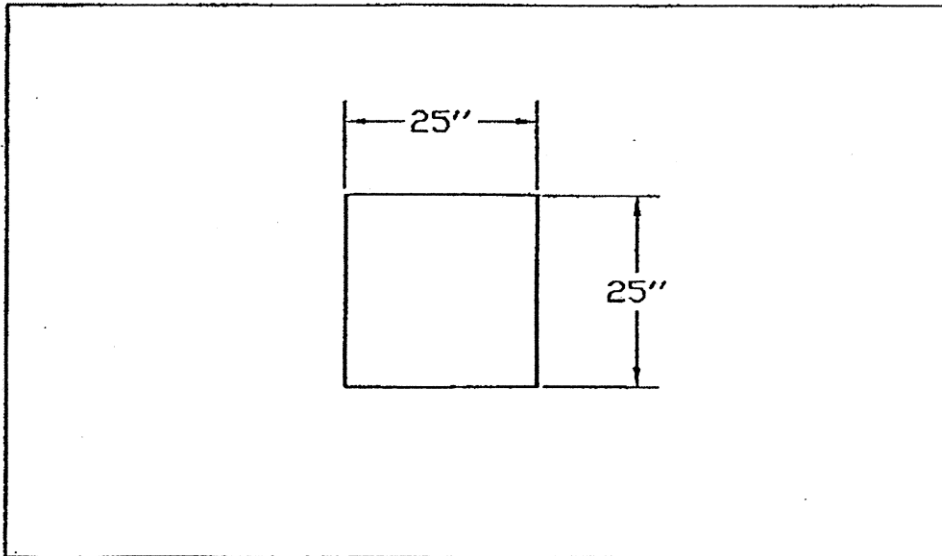

VENDOR NAME: _____
BNG

The School Board of Broward County, Florida
CAFETERIA EQUIPMENT

SECTION 6, ILLUSTRATIONS – (Continued)

BID ITEM 31

ATTACHMENT "A"

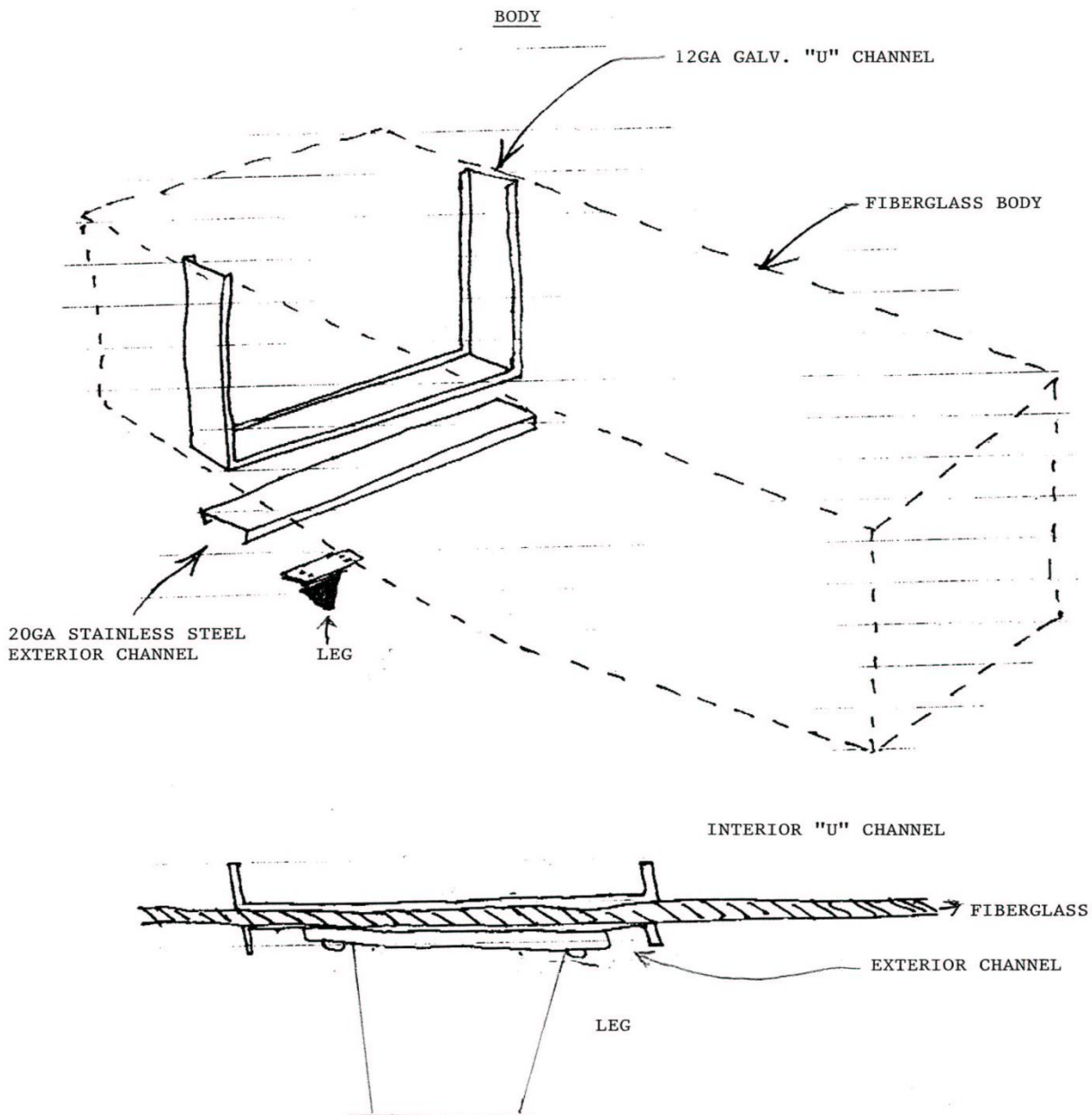

VENDOR NAME: _____
BNG

The School Board of Broward County, Florida
CAFETERIA EQUIPMENT

SECTION 6, ILLUSTRATIONS – (Continued)

BID ITEM 31

ATTACHMENT "B"

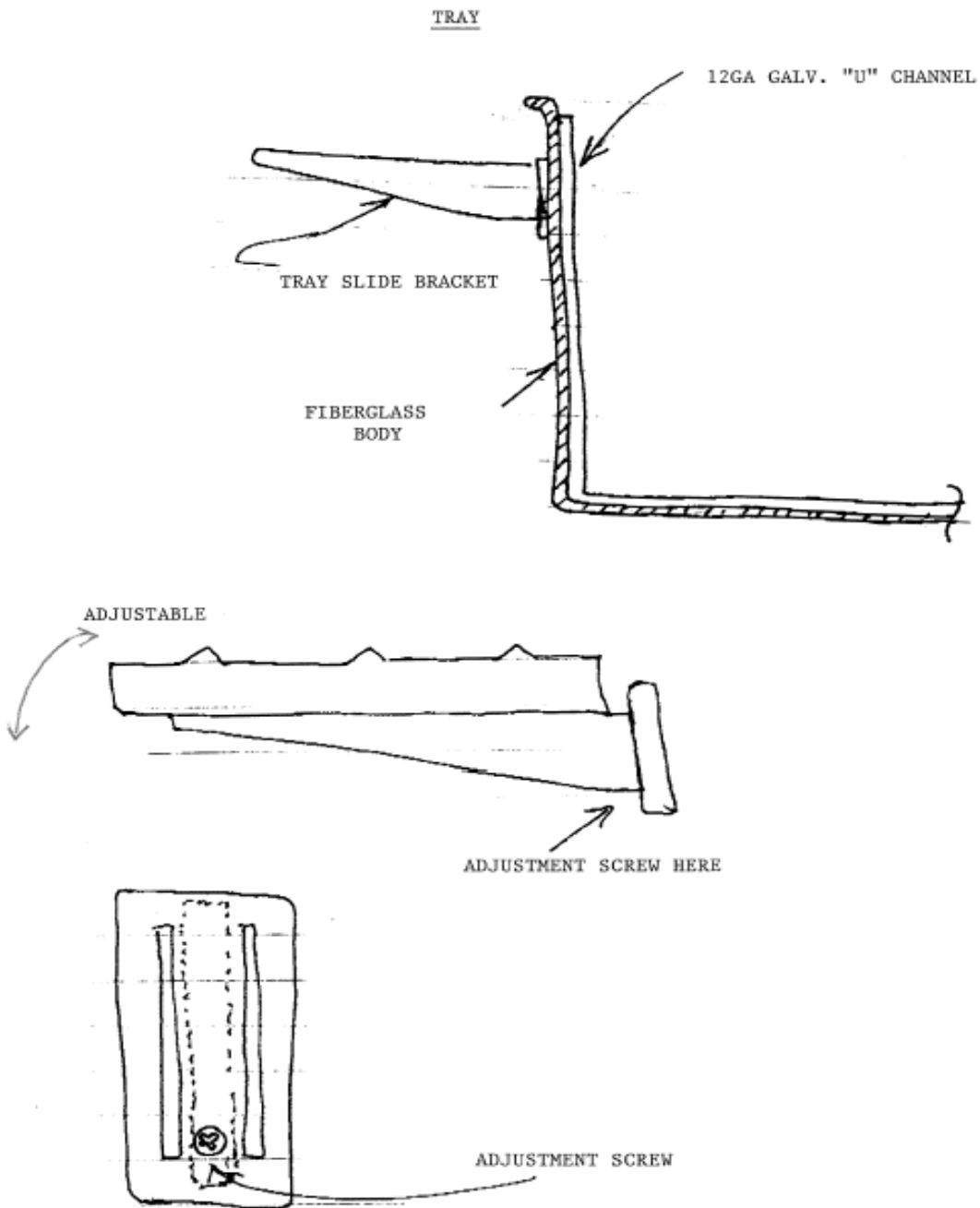

VENDOR NAME: _____
BNG

The School Board of Broward County, Florida
CAFETERIA EQUIPMENT

SECTION 6. ILLUSTRATIONS (Continued)

BID ITEM 49

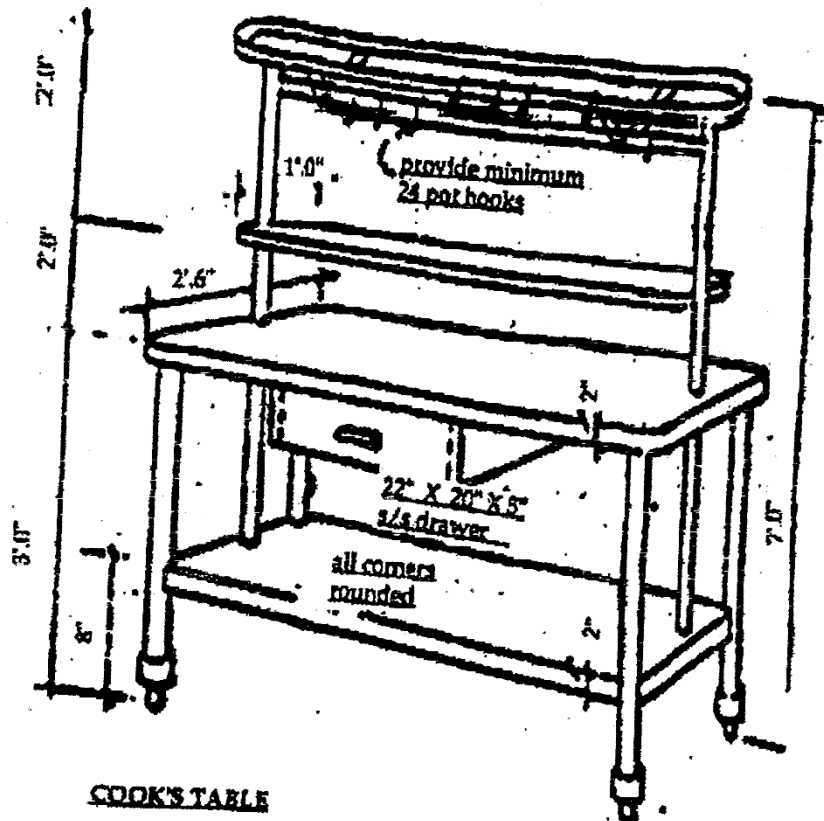

COOK'S TABLE

Table: 26" wide x 5" long
Legs & Shelf Supports: 1-t/8" O.D. s/s
with adjustable bullet feet.
Shelves & Top: 14 ga. s/s 18/8 type 304 s/s
on 1-1/2" x 1-1/2" 1/4" galv. iron frame.
N.S.F. Approved.
Drawer: In center, 15" x 20" x 5", s/s,
on ball bearing slides.

VENDOR NAME: _____
BNG

The School Board of Broward County, Florida
CAFETERIA EQUIPMENT

SECTION 7, ATTACHMENT 1

U. S. DEPARTMENT OF AGRICULTURE

Certification Regarding Debarment, Suspension,
Ineligibility and Voluntary Exclusion - Lower Tier Covered Transactions

This certification is required by the regulations implementing Executive Order 12549, Debarment and Suspension, 7 CFR Part 3017, Section 3017.510, as currently enacted or as amended from time to time, Participants responsibilities. The regulations were published as Part IV of the January 30, 1989, Federal Register (pages 4722-4733). Copies of the regulations may be obtained by contacting the Department of Agriculture agency with which this transaction originated.

(BEFORE COMPLETING CERTIFICATION, READ INSTRUCTIONS ON NEXT PAGE)

- (1) The prospective lower tier participant certifies, by submission of this proposal, that neither it nor its principals is presently debarred, suspended, proposed for debarment, declared ineligible, or voluntarily excluded from participation in this transaction by any Federal department or agency.
- (2) Where the prospective lower tier participant is unable to certify to any of the statements in this certification, such prospective participant shall attach an explanation to this proposal.

Organization Name

16-033B

PR/Award Number or Project Name

Name(s) and Title(s) of Authorized Representative(s)

Signature(s)

Date

Form AD - 1048 (1/92)

VENDOR NAME: _____
BNG

Instructions for Certification

1. By signing and submitting this form, the prospective lower tier participant is providing the certification set out on the reverse side in accordance with these instructions.
2. The certification in this clause is a material representation of fact upon which reliance was placed when this transaction was entered into. If it is later determined that the prospective lower tier participant knowingly rendered an erroneous certification, in addition to other remedies available to the Federal Government, the department or agency with which this transaction originated may pursue available remedies, including suspension and/or debarment.
3. The prospective lower tier participant shall provide immediate written notice to the person to which this proposal is submitted if at any time the prospective lower tier participant learns that its certification was erroneous when submitted or has become erroneous by reason of changed circumstances.
4. The terms “covered transaction,” “debarred,” “suspended,” “ineligible,” “lower tier covered transaction,” “participant,” “person,” “primary covered transaction,” “principal,” “proposal,” “voluntarily excluded,” as used in this clause, have the meanings set out in the Definitions and Coverage sections of rules implementing Executive Order 12549. You may contact the person to which this proposal is submitted for assistance in obtaining a copy of those regulations.
5. The prospective lower tier participant agrees by submitting this form that, should the proposed covered transaction be entered into, it shall not knowingly enter into any lower tier covered transaction with a person who is debarred, suspended, declared ineligible, or voluntarily excluded from participation in this covered transaction, unless authorized by the department or agency with which this transaction originated.
6. The prospective lower tier participant further agrees by submitting this form that it will include this clause titled “Certification Regarding Debarment, Suspension, Ineligibility and voluntary Exclusion - Lower Tier Covered Transactions,” without modification, in all lower tier covered transactions and in all solicitations for lower tier covered transactions.
7. A participant in a covered transaction may rely upon a certification of a prospective participant in a lower tier covered transaction that it is not debarred, suspended, ineligible, or voluntarily excluded from the covered transaction, unless it knows that the certification is erroneous. A participant may decide the method and frequency by which it determines the eligibility of its principals. Each participant may, but is not required to, check the Non procurement List.
8. Nothing contained in the foregoing shall be construed to require establishment of a system of records in order to render in good faith the certification required by this clause. The knowledge and information of a participant is not required to exceed that which is normally possessed by a prudent person in the ordinary course of business dealings.
9. Except for transactions authorized under paragraph 5 of these instructions, if a participant in a covered transaction knowingly enters into a lower tier covered transaction with a person who is suspended, debarred, ineligible, or voluntarily excluded from participation in this transaction, in addition to other remedies available to the Federal Government, the department or agency with which this transaction originated may pursue available remedies, including suspension and/or debarment.

Form AD - 1048 (1/92)

VENDOR NAME: _____

BNG

The School Board of Broward County, Florida
CAFETERIA EQUIPMENT

SECTION 7, ATTACHMENT 2
DISCLOSURE OF POTENTIAL CONFLICT OF INTEREST AND CONFLICTING EMPLOYMENT OR
CONTRACTUAL RELATIONSHIP

In accordance with General Condition 11, each Bidder must disclose in its Bid, the names of any employees who are employed by Bidder who are also an employees of SBBC. Persons identified below may have obligations and restrictions applicable to them under Chapter 112, Florida Statutes.

Name of Bidder's Employee	SBBC Title or Position of Bidder's Employee	SBBC Department/ School of Bidder's Employee
_____	_____	_____
_____	_____	_____
_____	_____	_____
_____	_____	_____
_____	_____	_____
_____	_____	_____

Check one of the following and sign:

- I hereby affirm that there are no known persons employed by Bidder who are also an employee of SBBC.
- I hereby affirm that all known persons who are employed by Bidder who are also an employee of SBBC have been identified above.

Signature

Company Name

03/28/13

VENDOR NAME: _____
BNG

**SECTION 7, ATTACHMENT 3
THE SCHOOL BOARD OF BROWARD COUNTY, FLORIDA**

SWORN STATEMENT PURSUANT TO SECTION 287.087, FLORIDA STATUTES, AS CURRENTLY ENACTED OR AS AMENDED FROM TIME TO TIME, ON PREFERENCE TO BUSINESSES WITH DRUG-FREE WORKPLACE PROGRAMS.

THIS FORM MUST BE SIGNED AND SWORN TO IN THE PRESENCE OF A NOTARY PUBLIC OR OTHER OFFICIAL AUTHORIZED TO ADMINISTER OATHS.

This sworn statement is submitted to The School Board of Broward County, Florida,

by _____
(Print individual's name and title)

for _____
(Print name of entity submitting sworn statement)

whose business address is _____

and (if applicable) its Federal Employer Identification Number (FEIN) is _____
(If the entity has no FEIN, include the Social Security Number of the individual signing this sworn statement: _____.)

I certify that I have established a drug-free workplace program and have complied with the following:

1. Published a statement notifying employees that the unlawful manufacture, distribution, dispensing, possession, or use of a controlled substance is prohibited in the workplace and specifying the actions that will be taken against employees for violations of such prohibition.
2. Informed employees about the dangers of drug abuse in the workplace, the business' policy of maintaining a drug-free workplace, any available drug counseling, rehabilitation and employee assistance programs, and the penalties that may be imposed upon employees for drug abuse violations.
3. Given each employee engaged in providing the commodities or contractual services that are under bid a copy of the statement specified in subsection (1).
4. In the statement specified in subsection (1), notified the employees that, as a condition of working on the commodities or contractual services that are under bid, the employee will abide by the terms of the statement and will notify the employer of any conviction of, or plea of guilty or nolo contendere to, any violation of chapter 893 or of any controlled substance law of the United States or any state, for a violation occurring in the workplace no later than five days after such conviction.
5. Will impose a sanction on, or require the satisfactory participation in a drug abuse assistance or rehabilitation program if such is available in the employee's community by, any employee who is so convicted.
6. Am making a good faith effort to continue to maintain a drug free workplace through implementation of this section.

(Signature)

Sworn to and subscribed before me this _____ day of _____, 20____.

Personally Known _____

OR Produced identification _____ Notary Public - State of _____

_____ My commission expires _____

(Type of identification)

(Printed, typed or stamped commissioned name of notary public)

The School Board of Broward County, Florida
CAFETERIA EQUIPMENT

SECTION 7, ATTACHMENT 4

INSURANCE REQUIREMENTS

MINIMUM LIMITS OF INSURANCE

GENERAL LIABILITY: Limits not less than \$1,000,000 per occurrence for Bodily Injury/ Property Damage; \$1,000,000 General Aggregate.

Limits not less than \$1,000,000 for Products/Completed Operations Aggregate.

WORKER'S COMPENSATION: Florida Statutory limits in accordance with Chapter 440; Employer's Liability limits not less than \$100,000/\$100,000/\$500,000 (each accident/disease-each employee/disease-policy limit).

AUTO LIABILITY: Owned, Non-Owned and Hired Auto Liability with Bodily Injury and Property Damage limits of not less than \$1,000,000 Combined Single Limit.

If Awardee does not own any vehicles, hired and non-owned automobile liability coverage in the amount of \$1,000,000 will be accepted. In addition, an affidavit signed by the Awardee must be furnished to SBBC indicating the following:

_____ (Awardee Name) does not own any vehicles. In the event insured acquires any vehicles throughout the term of this agreement, insured agrees to provide proof of "Any Auto" coverage effective the date of acquisition. (Fax affidavit with Certificate of Insurance to SBBC Risk Management at 866-897-0424.)

ACCEPTABILITY OF INSURANCE CARRIERS: The insurance policies shall be issued by companies qualified to do business in the State of Florida. The insurance companies must be rated at least A- VI by AM Best or Aa3 by Moody's Investor Service.

VERIFICATION OF COVERAGE: Proof of the required insurance must be furnished by an Awardee to SBBC Risk Management Department by Certificate of Insurance within 15 days of notification of award. All certificates (and any required documents) must be received and approved by SBBC before any work commences to permit Awardee time to remedy any deficiencies. **FAX CERTIFICATES OF INSURANCE TO SBBC RISK MANAGEMENT AT 866-897-0424.**

REQUIRED CONDITIONS: Liability policies must contain the following provisions. In addition, the following wording must be included on the Certificate of Insurance:

The School Board of Broward County, FL, its members, officers, employees and agents are added as additional insured. The endorsement # is: _____.

All liability policies are primary of all other valid and collectable coverage maintained by the School Board of Broward County, Florida.

(**Please include the Contract # and Title on the Certificate of Insurance.)

(Certificate Holder: School Board of Broward County, 600 Southeast Third Avenue, Fort Lauderdale, Florida 33301.)

CANCELLATION OF INSURANCE: Vendors are prohibited from providing services under this contract with SBBC without the minimum required insurance coverage and must notify SBBC within two business days if required insurance is cancelled.

Any questions as to the intent or meaning of any part of the above required coverage should be submitted in writing and in accordance with General Condition 5. See also General Conditions 12 and 20.

VENDOR NAME: _____

BNG

The School Board of Broward County, Florida
CAFETERIA EQUIPMENT

SECTION 7, ATTACHMENT 5 (See Special Condition 7)

LEGAL OPINION OF BIDDER'S PREFERENCE

MUST BE COMPLETED BY ALL BIDDERS.

Section 1 must be completed by the Attorney for an Out-of-State Bidder

Section 2 must be completed and signed by Florida Bidder

NOTICE: The State of Florida provides a Bidder's preference for Bidders whose principal place of business is within the State of Florida for the purchase of personal property. The local preference is five (5) percent. Bidders whose principal place of business is outside the State of Florida must have an Attorney, licensed to practice law in the out-of-state jurisdiction, as required by Florida Statute 287.084(2), execute the "Opinion of Out-of-State Bidder's Attorney on Bidding Preferences" form, Section 7, Attachment 5, and must submit this form with submitted bid. Such opinion should permit SBBC's reliance on such attorney's opinion for purposes of complying with Florida Statute 287.084. Florida Bidders are not required to have an Attorney render an opinion but the Florida Bidder must complete its portion of this form. Failure to submit and execute this form, with bid, shall result in bid being considered "non-responsive" and bid rejected.

SECTION 1

LEGAL OPINION ABOUT OUT-OF-STATE BIDDING PREFERENCES

(Must Select One)

_____ The Bidder's principal place of business is in the State of _____ and it is my legal opinion that the laws of that state **do not grant a preference** in the letting of any or all public contracts to business entities whose principal places of business are in that state.

_____ The Bidder's principal place of business is in the State of _____ and it is my legal opinion that the laws of that state **grant the following preference(s)** in the letting of any or all public contracts to business entities whose principal places of business are in that state: [Please describe applicable preference(s) and identify applicable state law(s)]:

The undersigned attorney submits the foregoing opinions with the intention that they be relied upon by The School Board of Broward County, Florida in the letting of public contracts

Signature of out-of-state Bidder's attorney:

Printed name of out-of-state Bidder's attorney:

Address of out-of-state Bidder's attorney:

Telephone Number of out-of-state Bidder's attorney: (____) ____ - _____

Email address of out-of-state Bidder's attorney: _____

Attorney's state(s) of bar admission: _____

SECTION 2

LEGAL OPINION ABOUT POLITICAL SUBDIVISION BIDDING PREFERENCES FOR A FLORIDA BIDDER ONLY
ATTORNEY'S OPINION AND SIGNATURE NOT REQUIRED FOR FLORIDA BIDDERS

(Must Select One)

_____ The Bidder's principal place of business is in the political subdivision of Broward County, Florida.

_____ The Bidder's principal place of business is in the political subdivision of _____ and it is my legal opinion that the laws of that political subdivision **do not grant a preference** in the letting of any or all public contracts to business entities whose principal places of business are in that political division.

_____ The Bidder's principal place of business is in the political subdivision of _____ and it is my legal opinion that the laws of that political subdivision **grant the following preference(s)** in the letting of any or all public contracts to business entities whose principal places of business are in that political subdivision: [Please describe applicable preference(s) and identify applicable authority granting the preference(s)]:

VENDOR NAME: _____

BNG

The School Board of Broward County, Florida
CAFETERIA EQUIPMENT

SECTION 7, ATTACHMENT 6

Form W-9 (Rev. August 2013) Department of the Treasury Internal Revenue Service	Request for Taxpayer Identification Number and Certification	Give Form to the requester. Do not send to the IRS.
Print or type See Specific Instructions on page 2.	Name (as shown on your income tax return)	
	Business name/disregarded entity name, if different from above	
	Check appropriate box for federal tax classification: <input type="checkbox"/> Individual/sole proprietor <input type="checkbox"/> C Corporation <input type="checkbox"/> S Corporation <input type="checkbox"/> Partnership <input type="checkbox"/> Trust/estate <input type="checkbox"/> Limited liability company. Enter the tax classification (C=C corporation, S=S corporation, P=partnership) ▶ _____ <input type="checkbox"/> Other (see instructions) ▶ _____	Exemptions (see instructions): Exempt payee code (if any) _____ Exemption from FATCA reporting code (if any) _____
	Address (number, street, and apt. or suite no.)	Requester's name and address (optional)
City, state, and ZIP code		
List account number(s) here (optional)		

Part I Taxpayer Identification Number (TIN)

Enter your TIN in the appropriate box. The TIN provided must match the name given on the "Name" line to avoid backup withholding. For individuals, this is your social security number (SSN). However, for a resident alien, sole proprietor, or disregarded entity, see the Part I instructions on page 3. For other entities, it is your employer identification number (EIN). If you do not have a number, see *How to get a TIN* on page 3.

Note. If the account is in more than one name, see the chart on page 4 for guidelines on whose number to enter.

Social security number
[] [] [] - [] [] [] - [] [] [] [] [] []
Employer identification number
[] [] [] [] - [] [] [] [] [] [] [] []

Part II Certification

Under penalties of perjury, I certify that:

- The number shown on this form is my correct taxpayer identification number (or I am waiting for a number to be issued to me), and
- I am not subject to backup withholding because: (a) I am exempt from backup withholding, or (b) I have not been notified by the Internal Revenue Service (IRS) that I am subject to backup withholding as a result of a failure to report all interest or dividends, or (c) the IRS has notified me that I am no longer subject to backup withholding, and
- I am a U.S. citizen or other U.S. person (defined below), and
- The FATCA code(s) entered on this form (if any) indicating that I am exempt from FATCA reporting is correct.

Certification instructions. You must cross out item 2 above if you have been notified by the IRS that you are currently subject to backup withholding because you have failed to report all interest and dividends on your tax return. For real estate transactions, item 2 does not apply. For mortgage interest paid, acquisition or abandonment of secured property, cancellation of debt, contributions to an individual retirement arrangement (IRA), and generally, payments other than interest and dividends, you are not required to sign the certification, but you must provide your correct TIN. See the instructions on page 3.

Sign Here	Signature of U.S. person ▶	Date ▶
------------------	----------------------------	--------

General Instructions

Section references are to the Internal Revenue Code unless otherwise noted.
Future developments. The IRS has created a page on IRS.gov for information about Form W-9, at www.irs.gov/w9. Information about any future developments affecting Form W-9 (such as legislation enacted after we release it) will be posted on that page.

Purpose of Form

A person who is required to file an information return with the IRS must obtain your correct taxpayer identification number (TIN) to report, for example, income paid to you, payments made to you in settlement of payment card and third party network transactions, real estate transactions, mortgage interest you paid, acquisition or abandonment of secured property, cancellation of debt, or contributions you made to an IRA.

Use Form W-9 only if you are a U.S. person (including a resident alien), to provide your correct TIN to the person requesting it (the requester) and, when applicable, to:

- Certify that the TIN you are giving is correct (or you are waiting for a number to be issued),
- Certify that you are not subject to backup withholding, or
- Claim exemption from backup withholding if you are a U.S. exempt payee. If applicable, you are also certifying that as a U.S. person, your allocable share of any partnership income from a U.S. trade or business is not subject to the

withholding tax on foreign partners' share of effectively connected income, and
 4. Certify that FATCA code(s) entered on this form (if any) indicating that you are exempt from the FATCA reporting, is correct.

Note. If you are a U.S. person and a requester gives you a form other than Form W-9 to request your TIN, you must use the requester's form if it is substantially similar to this Form W-9.

Definition of a U.S. person. For federal tax purposes, you are considered a U.S. person if you are:

- An individual who is a U.S. citizen or U.S. resident alien,
- A partnership, corporation, company, or association created or organized in the United States or under the laws of the United States,
- An estate (other than a foreign estate), or
- A domestic trust (as defined in Regulations section 301.7701-7).

Special rules for partnerships. Partnerships that conduct a trade or business in the United States are generally required to pay a withholding tax under section 1446 on any foreign partners' share of effectively connected taxable income from such business. Further, in certain cases where a Form W-9 has not been received, the rules under section 1446 require a partnership to presume that a partner is a foreign person, and pay the section 1446 withholding tax. Therefore, if you are a U.S. person that is a partner in a partnership conducting a trade or business in the United States, provide Form W-9 to the partnership to establish your U.S. status and avoid section 1446 withholding on your share of partnership income.

VENDOR NAME: _____
BNG

In the cases below, the following person must give Form W-9 to the partnership for purposes of establishing its U.S. status and avoiding withholding on its allocable share of net income from the partnership conducting a trade or business in the United States:

- In the case of a disregarded entity with a U.S. owner, the U.S. owner of the disregarded entity and not the entity.
- In the case of a grantor trust with a U.S. grantor or other U.S. owner, generally, the U.S. grantor or other U.S. owner of the grantor trust and not the trust, and
- In the case of a U.S. trust (other than a grantor trust), the U.S. trust (other than a grantor trust) and not the beneficiaries of the trust.

Foreign person. If you are a foreign person or the U.S. branch of a foreign bank that has elected to be treated as a U.S. person, do not use Form W-9. Instead, use the appropriate Form W-8 or Form 8233 (see Publication 515, Withholding of Tax on Nonresident Aliens and Foreign Entities).

Nonresident alien who becomes a resident alien. Generally, only a nonresident alien individual may use the terms of a tax treaty to reduce or eliminate U.S. tax on certain types of income. However, most tax treaties contain a provision known as a "saving clause." Exceptions specified in the saving clause may permit an exemption from tax to continue for certain types of income even after the payee has otherwise become a U.S. resident alien for tax purposes.

If you are a U.S. resident alien who is relying on an exception contained in the saving clause of a tax treaty to claim an exemption from U.S. tax on certain types of income, you must attach a statement to Form W-9 that specifies the following five items:

1. The treaty country. Generally, this must be the same treaty under which you claimed exemption from tax as a nonresident alien.
2. The treaty article addressing the income.
3. The article number (or location) in the tax treaty that contains the saving clause and its exceptions.
4. The type and amount of income that qualifies for the exemption from tax.
5. Sufficient facts to justify the exemption from tax under the terms of the treaty article.

Example. Article 20 of the U.S.-China income tax treaty allows an exemption from tax for scholarship income received by a Chinese student temporarily present in the United States. Under U.S. law, this student will become a resident alien for tax purposes if his or her stay in the United States exceeds 5 calendar years. However, paragraph 2 of the first Protocol to the U.S.-China treaty (dated April 30, 1984) allows the provisions of Article 20 to continue to apply even after the Chinese student becomes a resident alien of the United States. A Chinese student who qualifies for this exception (under paragraph 2 of the first protocol) and is relying on this exception to claim an exemption from tax on his or her scholarship or fellowship income would attach to Form W-9 a statement that includes the information described above to support that exemption.

If you are a nonresident alien or a foreign entity, give the requester the appropriate completed Form W-8 or Form 8233.

What is backup withholding? Persons making certain payments to you must under certain conditions withhold and pay to the IRS a percentage of such payments. This is called "backup withholding." Payments that may be subject to backup withholding include interest, tax-exempt interest, dividends, broker and barter exchange transactions, rents, royalties, nonemployee pay, payments made in settlement of payment card and third party network transactions, and certain payments from fishing boat operators. Real estate transactions are not subject to backup withholding.

You will not be subject to backup withholding on payments you receive if you give the requester your correct TIN, make the proper certifications, and report all your taxable interest and dividends on your tax return.

Payments you receive will be subject to backup withholding if:

1. You do not furnish your TIN to the requester,
2. You do not certify your TIN when required (see the Part II Instructions on page 3 for details),
3. The IRS tells the requester that you furnished an incorrect TIN,
4. The IRS tells you that you are subject to backup withholding because you did not report all your interest and dividends on your tax return (for reportable interest and dividends only), or
5. You do not certify to the requester that you are not subject to backup withholding under 4 above (for reportable interest and dividend accounts opened after 1983 only).

Certain payees and payments are exempt from backup withholding. See Exempt payee code on page 3 and the separate Instructions for the Requester of Form W-9 for more information.

Also see Special rules for partnerships on page 1.

What is FATCA reporting? The Foreign Account Tax Compliance Act (FATCA) requires a participating foreign financial institution to report all United States account holders that are specified United States persons. Certain payees are exempt from FATCA reporting. See Exemption from FATCA reporting code on page 3 and the Instructions for the Requester of Form W-9 for more information.

Updating Your Information

You must provide updated information to any person to whom you claimed to be an exempt payee if you are no longer an exempt payee and anticipate receiving reportable payments in the future from this person. For example, you may need to provide updated information if you are a C corporation that elects to be an S corporation, or if you no longer are tax exempt. In addition, you must furnish a new Form W-9 if the name or TIN changes for the account, for example, if the grantor of a grantor trust dies.

Penalties

Failure to furnish TIN. If you fail to furnish your correct TIN to a requester, you are subject to a penalty of \$50 for each such failure unless your failure is due to reasonable cause and not to willful neglect.

Civil penalty for false information with respect to withholding. If you make a false statement with no reasonable basis that results in no backup withholding, you are subject to a \$500 penalty.

Criminal penalty for falsifying information. Willfully falsifying certifications or affirmations may subject you to criminal penalties including fines and/or imprisonment.

Misuse of TINs. If the requester discloses or uses TINs in violation of federal law, the requester may be subject to civil and criminal penalties.

Specific Instructions

Name

If you are an individual, you must generally enter the name shown on your income tax return. However, if you have changed your last name, for instance, due to marriage without informing the Social Security Administration of the name change, enter your first name, the last name shown on your social security card, and your new last name.

If the account is in joint names, list first, and then circle, the name of the person or entity whose number you entered in Part I of the form.

Sole proprietor. Enter your individual name as shown on your income tax return on the "Name" line. You may enter your business, trade, or "doing business as (DBA)" name on the "Business name/disregarded entity name" line.

Partnership, C Corporation, or S Corporation. Enter the entity's name on the "Name" line and any business, trade, or "doing business as (DBA) name" on the "Business name/disregarded entity name" line.

Disregarded entity. For U.S. federal tax purposes, an entity that is disregarded as an entity separate from its owner is treated as a "disregarded entity." See Regulation section 301.7701-2(c)(2)(ii). Enter the owner's name on the "Name" line. The name of the entity entered on the "Name" line should never be a disregarded entity. The name on the "Name" line must be the name shown on the income tax return on which the income should be reported. For example, if a foreign LLC that is treated as a disregarded entity for U.S. federal tax purposes has a single owner that is a U.S. person, the U.S. owner's name is required to be provided on the "Name" line. If the direct owner of the entity is also a disregarded entity, enter the first owner that is not disregarded for federal tax purposes. Enter the disregarded entity's name on the "Business name/disregarded entity name" line. If the owner of the disregarded entity is a foreign person, the owner must complete an appropriate Form W-8 instead of a Form W-9. This is the case even if the foreign person has a U.S. TIN.

Note. Check the appropriate box for the U.S. federal tax classification of the person whose name is entered on the "Name" line (Individual/sole proprietor, Partnership, C Corporation, S Corporation, Trust/estate).

Limited Liability Company (LLC). If the person identified on the "Name" line is an LLC, check the "limited liability company" box only and enter the appropriate code for the U.S. federal tax classification in the space provided. If you are an LLC that is treated as a partnership for U.S. federal tax purposes, enter "P" for partnership. If you are an LLC that has filed a Form 8832 or a Form 2553 to be taxed as a corporation, enter "C" for C corporation or "S" for S corporation, as appropriate. If you are an LLC that is disregarded as an entity separate from its owner under Regulation section 301.7701-3 (except for employment and excise tax), do not check the LLC box unless the owner of the LLC (required to be identified on the "Name" line) is another LLC that is not disregarded for U.S. federal tax purposes. If the LLC is disregarded as an entity separate from its owner, enter the appropriate tax classification of the owner identified on the "Name" line.

Other entities. Enter your business name as shown on required U.S. federal tax documents on the "Name" line. This name should match the name shown on the charter or other legal document creating the entity. You may enter any business, trade, or DBA name on the "Business name/disregarded entity name" line.

Exemptions

If you are exempt from backup withholding and/or FATCA reporting, enter in the Exemptions box, any code(s) that may apply to you. See Exempt payee code and Exemption from FATCA reporting code on page 3.

VENDOR NAME: _____
BNG

Exempt payee code. Generally, individuals (including sole proprietors) are not exempt from backup withholding. Corporations are exempt from backup withholding for certain payments, such as interest and dividends. Corporations are not exempt from backup withholding for payments made in settlement of payment card or third party network transactions.

Note. If you are exempt from backup withholding, you should still complete this form to avoid possible erroneous backup withholding.

The following codes identify payees that are exempt from backup withholding:

- 1—An organization exempt from tax under section 501(a), any IRA, or a custodial account under section 403(b)(7) if the account satisfies the requirements of section 401(f)(2)
- 2—The United States or any of its agencies or instrumentalities
- 3—A state, the District of Columbia, a possession of the United States, or any of their political subdivisions or instrumentalities
- 4—A foreign government or any of its political subdivisions, agencies, or instrumentalities
- 5—A corporation
- 6—A dealer in securities or commodities required to register in the United States, the District of Columbia, or a possession of the United States
- 7—A futures commission merchant registered with the Commodity Futures Trading Commission
- 8—A real estate investment trust
- 9—An entity registered at all times during the tax year under the Investment Company Act of 1940
- 10—A common trust fund operated by a bank under section 584(a)
- 11—A financial institution
- 12—A middleman known in the investment community as a nominee or custodian
- 13—A trust exempt from tax under section 664 or described in section 4947

The following chart shows types of payments that may be exempt from backup withholding. The chart applies to the exempt payees listed above, 1 through 13.

IF the payment is for . . .	THEN the payment is exempt for . . .
Interest and dividend payments	All exempt payees except for 7
Broker transactions	Exempt payees 1 through 4 and 6 through 11 and all C corporations. S corporations must not enter an exempt payee code because they are exempt only for sales of noncovered securities acquired prior to 2012.
Barter exchange transactions and patronage dividends	Exempt payees 1 through 4
Payments over \$600 required to be reported and direct sales over \$5,000 ¹	Generally, exempt payees 1 through 5 ²
Payments made in settlement of payment card or third party network transactions	Exempt payees 1 through 4

¹ See Form 1099-MISC, Miscellaneous Income, and its instructions.

² However, the following payments made to a corporation and reportable on Form 1099-MISC are not exempt from backup withholding: medical and health care payments, attorneys' fees, gross proceeds paid to an attorney, and payments for services paid by a federal executive agency.

Exemption from FATCA reporting code. The following codes identify payees that are exempt from reporting under FATCA. These codes apply to persons submitting this form for accounts maintained outside of the United States by certain foreign financial institutions. Therefore, if you are only submitting this form for an account you hold in the United States, you may leave this field blank. Consult with the person requesting this form if you are uncertain if the financial institution is subject to these requirements.

- A—An organization exempt from tax under section 501(a) or any individual retirement plan as defined in section 7701(a)(37)
- B—The United States or any of its agencies or instrumentalities
- C—A state, the District of Columbia, a possession of the United States, or any of their political subdivisions or instrumentalities
- D—A corporation the stock of which is regularly traded on one or more established securities markets, as described in Reg. section 1.1472-1(c)(1)(i)
- E—A corporation that is a member of the same expanded affiliated group as a corporation described in Reg. section 1.1472-1(c)(1)(i)
- F—A dealer in securities, commodities, or derivative financial instruments (including notional principal contracts, futures, forwards, and options) that is registered as such under the laws of the United States or any state

- G—A real estate investment trust
- H—A regulated investment company as defined in section 851 or an entity registered at all times during the tax year under the Investment Company Act of 1940
- I—A common trust fund as defined in section 584(a)
- J—A bank as defined in section 581
- K—A broker
- L—A trust exempt from tax under section 664 or described in section 4947(b)(1)
- M—A tax exempt trust under a section 403(b) plan or section 457(g) plan

Part I. Taxpayer Identification Number (TIN)

Enter your TIN in the appropriate box. If you are a resident alien and you do not have and are not eligible to get an SSN, your TIN is your IRS individual taxpayer identification number (ITIN). Enter it in the social security number box. If you do not have an ITIN, see *How to get a TIN* below.

If you are a sole proprietor and you have an EIN, you may enter either your SSN or EIN. However, the IRS prefers that you use your SSN.

If you are a single-member LLC that is disregarded as an entity separate from its owner (see *Limited Liability Company (LLC)* on page 2), enter the owner's SSN (or EIN, if the owner has one). Do not enter the disregarded entity's EIN. If the LLC is classified as a corporation or partnership, enter the entity's EIN.

Note. See the chart on page 4 for further clarification of name and TIN combinations.

How to get a TIN. If you do not have a TIN, apply for one immediately. To apply for an SSN, get Form SS-5, Application for a Social Security Card, from your local Social Security Administration office or get this form online at www.ssa.gov. You may also get this form by calling 1-800-772-1213. Use Form W-7, Application for IRS Individual Taxpayer Identification Number, to apply for an ITIN, or Form SS-4, Application for Employer Identification Number, to apply for an EIN. You can apply for an EIN online by accessing the IRS website at www.irs.gov/businesses and clicking on Employer Identification Number (EIN) under Starting a Business. You can get Forms W-7 and SS-4 from the IRS by visiting IRS.gov or by calling 1-800-TAX-FORM (1-800-829-3676).

If you are asked to complete Form W-9 but do not have a TIN, apply for a TIN and write "Applied For" in the space for the TIN, sign and date the form, and give it to the requester. For interest and dividend payments, and certain payments made with respect to readily tradable instruments, generally you will have 60 days to get a TIN and give it to the requester before you are subject to backup withholding on payments. The 60-day rule does not apply to other types of payments. You will be subject to backup withholding on all such payments until you provide your TIN to the requester.

Note. Entering "Applied For" means that you have already applied for a TIN or that you intend to apply for one soon.

Caution: A disregarded U.S. entity that has a foreign owner must use the appropriate Form W-8.

Part II. Certification

To establish to the withholding agent that you are a U.S. person, or resident alien, sign Form W-9. You may be requested to sign by the withholding agent even if items 1, 4, or 5 below indicate otherwise.

For a joint account, only the person whose TIN is shown in Part I should sign (when required). In the case of a disregarded entity, the person identified on the "Name" line must sign. Exempt payees, see *Exempt payee code* earlier.

Signature requirements. Complete the certification as indicated in items 1 through 5 below.

1. **Interest, dividend, and barter exchange accounts opened before 1984 and broker accounts considered active during 1983.** You must give your correct TIN, but you do not have to sign the certification.

2. **Interest, dividend, broker, and barter exchange accounts opened after 1983 and broker accounts considered inactive during 1983.** You must sign the certification or backup withholding will apply. If you are subject to backup withholding and you are merely providing your correct TIN to the requester, you must cross out item 2 in the certification before signing the form.

3. **Real estate transactions.** You must sign the certification. You may cross out item 2 of the certification.

4. **Other payments.** You must give your correct TIN, but you do not have to sign the certification unless you have been notified that you have previously given an incorrect TIN. "Other payments" include payments made in the course of the requester's trade or business for rents, royalties, goods (other than bills for merchandise), medical and health care services (including payments to corporations), payments to a nonemployee for services, payments made in settlement of payment card and third party network transactions, payments to certain fishing boat crew members and fishermen, and gross proceeds paid to attorneys (including payments to corporations).

5. **Mortgage interest paid by you, acquisition or abandonment of secured property, cancellation of debt, qualified tuition program payments (under section 529), IRA, Coverdell ESA, Archer MSA or HSA contributions or distributions, and pension distributions.** You must give your correct TIN, but you do not have to sign the certification.

VENDOR NAME: _____
BNG

What Name and Number To Give the Requester

For this type of account:	Give name and SSN of:
1. Individual	The individual
2. Two or more individuals (joint account)	The actual owner of the account or, if combined funds, the first individual on the account ¹
3. Custodian account of a minor (Uniform Gift to Minors Act)	The minor ²
4. a. The usual revocable savings trust (grantor is also trustee) b. So-called trust account that is not a legal or valid trust under state law	The grantor-trustee ³ The actual owner ⁴
5. Sole proprietorship or disregarded entity owned by an individual	The owner ⁴
6. Grantor trust filing under Optional Form 1099 Filing Method 1 (see Regulation section 1.671-4(b)(2)(i)(A))	The grantor ⁴
For this type of account:	Give name and EIN of:
7. Disregarded entity not owned by an individual	The owner
8. A valid trust, estate, or pension trust	Legal entity ⁴
9. Corporation or LLC electing corporate status on Form 8832 or Form 2553	The corporation
10. Association, club, religious, charitable, educational, or other tax-exempt organization	The organization
11. Partnership or multi-member LLC	The partnership
12. A broker or registered nominee	The broker or nominee
13. Account with the Department of Agriculture in the name of a public entity (such as a state or local government, school district, or prison) that receives agricultural program payments	The public entity
14. Grantor trust filing under the Form 1041 Filing Method or the Optional Form 1099 Filing Method 2 (see Regulation section 1.671-4(b)(2)(i)(B))	The trust

¹ List first and circle the name of the person whose number you furnish. If only one person on a joint account has an SSN, that person's number must be furnished.

² Circle the minor's name and furnish the minor's SSN.

³ You must show your individual name and you may also enter your business or "DBA" name on the "Business name/disregarded entity" name line. You may use either your SSN or EIN (if you have one), but the IRS encourages you to use your SSN.

⁴ List first and circle the name of the trust, estate, or pension trust. (Do not furnish the TIN of the personal representative or trustee unless the legal entity itself is not designated in the account title.) Also see Special rules for partnerships on page 1.

*Note. Grantor also must provide a Form W-9 to trustee of trust.

Note. If no name is circled when more than one name is listed, the number will be considered to be that of the first name listed.

Secure Your Tax Records from Identity Theft

Identity theft occurs when someone uses your personal information such as your name, social security number (SSN), or other identifying information, without your permission, to commit fraud or other crimes. An identity thief may use your SSN to get a job or may file a tax return using your SSN to receive a refund.

To reduce your risk:

- Protect your SSN,
- Ensure your employer is protecting your SSN, and
- Be careful when choosing a tax preparer.

If your tax records are affected by identity theft and you receive a notice from the IRS, respond right away to the name and phone number printed on the IRS notice or letter.

If your tax records are not currently affected by identity theft but you think you are at risk due to a lost or stolen purse or wallet, questionable credit card activity or credit report, contact the IRS Identity Theft Hotline at 1-800-908-4490 or submit Form 14039.

For more information, see Publication 4535, Identity Theft Prevention and Victim Assistance.

Victims of identity theft who are experiencing economic harm or a system problem, or are seeking help in resolving tax problems that have not been resolved through normal channels, may be eligible for Taxpayer Advocate Service (TAS) assistance. You can reach TAS by calling the TAS toll-free case intake line at 1-877-777-4778 or TTY/TDD 1-800-829-4050.

Protect yourself from suspicious emails or phishing schemes. Phishing is the creation and use of email and websites designed to mimic legitimate business emails and websites. The most common act is sending an email to a user falsely claiming to be an established legitimate enterprise in an attempt to scam the user into surrendering private information that will be used for identity theft.

The IRS does not initiate contacts with taxpayers via emails. Also, the IRS does not request personal detailed information through email or ask taxpayers for the PIN numbers, passwords, or similar secret access information for their credit card, bank, or other financial accounts.

If you receive an unsolicited email claiming to be from the IRS, forward this message to phishing@irs.gov. You may also report misuse of the IRS name, logo, or other IRS property to the Treasury Inspector General for Tax Administration at 1-800-366-4484. You can forward suspicious emails to the Federal Trade Commission at spam@uce.gov or contact them at www.ftc.gov/idtheft or 1-877-IDTHEFT (1-877-438-4338).

Visit irs.gov to learn more about identity theft and how to reduce your risk.

Privacy Act Notice

Section 6109 of the Internal Revenue Code requires you to provide your correct TIN to persons (including federal agencies) who are required to file information returns with the IRS to report interest, dividends, or certain other income paid to you; mortgage interest you paid; the acquisition or abandonment of secured property; the cancellation of debt; or contributions you made to an IRA, Archer MSA, or HSA. The person collecting this form uses the information on the form to file information returns with the IRS, reporting the above information. Routine uses of this information include giving it to the Department of Justice for civil and criminal litigation and to cities, states, the District of Columbia, and U.S. commonwealths and possessions for use in administering their laws. The information also may be disclosed to other countries under a treaty, to federal and state agencies to enforce civil and criminal laws, or to federal law enforcement and intelligence agencies to combat terrorism. You must provide your TIN whether or not you are required to file a tax return. Under section 3406, payers must generally withhold a percentage of taxable interest, dividend, and certain other payments to a payee who does not give a TIN to the payer. Certain penalties may also apply for providing false or fraudulent information.

VENDOR NAME: _____
BNG



The School Board of Broward County, Florida
ACH Payment Agreement Form (ACH CREDITS)
(See General Condition 10)

VENDOR NAME:

Authorization Agreement

I (we) hereby authorize **The School Board of Broward County** to initiate automatic deposits (credits) to my account at the financial institution named below. Additionally, I authorize **The School Board of Broward County** to make the necessary debit entries/adjustments in the event that a credit entry is made in error.

Further, I agree not to hold **The School Board of Broward County** responsible for any delay or loss of funds due to incorrect or incomplete information supplied by me or by my financial institution or due to an error on the part of my financial institution in depositing funds to my account.

This agreement will remain in effect until **The School Board of Broward County** receives written notification of cancellation from me or my financial institution and that the origination of ACH transactions to my (our) account must comply with the provisions of U.S. law.

Account Information

Name of Bank or Financial Institution: _____

Branch/ State _____

Routing No: _____

Account No: _____
Checking Savings

VENDOR AREA:
Remittance Confirmation: (please select one) _____
Fax Email

Federal Identification No. Vendor _____
TAX ID# SS#

Update Purchase Order Fax & Email Address

Centralized Fax Number _____ Dept. _____

Centralized Email _____ Dept. _____

Centralized Phone No. _____ Dept. _____

Signature

Authorized Signature (Primary) and Business title: _____ Date: _____

Authorized Signature (Joint) and Business title: _____ Date: _____

Please attach a VOIDED check to verify bank details and routing number.

This form must be returned to: SBBC – Purchasing – Data Strategy Group
7720 W. Oakland Park Blvd, Sunrise FL 33351 call: 754-321-0516 or fax # 754-321-0533

For Use by DATA STRATEGY GROUP

Vendor Account# _____ Date Entered _____ Initials: _____

VENDOR NAME: _____

BNG

SECTION 8, STATEMENT OF "NO BID"

If your company will not be submitting a bid in response to this Invitation to Bid, please complete this Statement of "No Bid" Sheet and return, prior to the Bid Due Date established within, to:

The School Board of Broward County, Florida
Procurement and Warehousing Services
7720 West Oakland Park Boulevard, Suite 323
Sunrise, Florida 33351

This information will help SBBC in the preparation of future Bids.

Bid Number: _____ Title: _____

Company Name: _____

Contact: _____

Address: _____

Telephone: _____ Facsimile: _____

<input checked="" type="checkbox"/>	Reasons for "NO Bid":
<input type="checkbox"/>	Unable to comply with product or service specifications.
<input type="checkbox"/>	Unable to comply with scope of work.
<input type="checkbox"/>	Unable to quote on all items in the group.
<input type="checkbox"/>	Insufficient time to respond to the Invitation to Bid.
<input type="checkbox"/>	Unable to hold prices firm through the term of the contract period.
<input type="checkbox"/>	Our schedule would not permit us to perform.
<input type="checkbox"/>	Unable to meet delivery requirements.
<input type="checkbox"/>	Unable to meet bond requirements.
<input type="checkbox"/>	Unable to meet insurance requirements.
<input type="checkbox"/>	Other (Specify below)

Comments:

Signature: _____ Date: _____

VENDOR NAME: _____

BNG

**EXHIBIT A
M/WBE PARTICIPATION**

Complete the following information on the proposed M/WBE participation on this contract.

Proposer's Company Name: _____

M/WBE Firm Information	Scope and/or Nature of Work to be Performed by the M/WBE	PROVIDE % of M/WBE Participation for this contract	Actual Amount to be expended with M/WBE *
Firm Name: _____ Contact Person: _____ Address: _____ _____ Telephone No.: _____ Facsimile No.: _____ SBBC M/WBE Certification No.: _____			
Firm Name: _____ Contact Person: _____ Address: _____ _____ Telephone No.: _____ Facsimile No.: _____ SBBC M/WBE Certification No.: _____			
Firm Name: _____ Contact Person: _____ Address: _____ _____ Telephone No.: _____ Facsimile No.: _____ SBBC M/WBE Certification No.: _____			

* PLEASE INDICATE IF AMOUNT TO BE EXPENSED IS: PER YEAR - PER CONTRACT PERIOD OR OTHER

A LIST OF SBBC M/WBE CERTIFIED VENDORS CAN BE FOUND AT THIS WEBSITE.

<http://www.broward.k12.fl.us/supply/vendors/MWBE.htm>

VENDOR NAME: _____
BNG

Exhibit A

**The School Board of Broward County, Florida
Supplier Diversity & Outreach Program 7720 W.
Oakland Park Blvd., Suite 323
Sunrise, FL 33351
(754) 321-0505 ~ Fax (754) 321-0533**

Monthly M/WBE Utilization Report

This report is required 15 days after the end of each month, whether the M/WBE(s) received payments or not, until all committed remuneration has been received by the M/WBE.

Reporting Period From: _____ Reporting Period To: _____

This report is required by The School Board of Broward County, Florida. Failure to comply may result in the School Board commencing proceedings to impose sanctions on the Prime Vendor, in addition to pursuing any other available legal remedy. Sanctions may include the withholding of payments for work committed to M/WBE participants, and a negative recommendation to award further contracts bid by The School Board of Broward County, Florida.

Prime Vendor Information

NAME & ADDRESS OF PRIME VENDOR:	CONTRACT AMOUNT (if applicable)	LENGTH OF CONTRACT	CONTRACT START DATE	CONTRACT END DATE	TOTAL % OR \$ AMOUNT TO MINORITY/ WOMEN
Bid Number:					
Bid Title:					

SUPPLIER DIVERSITY & OUTREACH PROGRAM VENDOR INFORMATION

NAME OF CERTIFIED M/WBE VENDOR	WORK DESCRIPTION	AMOUNT PAID TO VENDOR	AMOUNT PAID TO DATE	% of TOTAL PAID TO CONTRACT AMOUNT

Company Official's Signature: _____
(Signature)

Printed Name: _____ **Title:** _____

Phone #: (_____) - _____ **Date:** _____

VENDOR NAME: _____
BNG